

POLYPHONY

New Music Technology for July/August 1980



PETER GABRIEL on TOUR

Digital VCO
Dream Modules



SWT ANALOG DELAY



INTRODUCING... TWO-CHANNEL ANALOG DELAY UNIT FOR AMBIENCE SYNTHESIS AND DELAY EFFECTS

FEATURES

- * TWO INDEPENDENT CHANNELS
- * 3072 STAGES OF DELAY PER CHANNEL
- * ADJUSTABLE INPUT AND OUTPUT LEVELS WITH INPUT OVERLOAD INDICATION
- * INTERNAL OR EXTERNAL VOLTAGE CONTROLLED DELAY TIME
- * COMPANDOR IN EACH CHANNEL
- * 3 MODES/CHANNEL WITH ADJUSTABLE MIX
- * CONVENTIONAL REVERB OUTPUT FOR MUSIC EFFECTS

If you haven't heard what analog delay can do for home music reproduction, you're missing something. Let's face it, stereo in your living room is flat and

2 dimensional. Without the mixture of direct and delayed sounds that a large hall provides, almost all music reproduced in the home is lifeless. Quadraphonics has not proved to be the solution to this problem. The recent development of bucket-brigade semiconductor technology has made it possible to offer a reasonably priced delay unit that can transform your listening room into a concert hall. Using your present stereo system, the 2AS-A, and whatever you have in the way of 2 additional speakers and 2 channels of power amplification—you have all the parts to put together an ambience system that is capable of creating the kind of 'space' you enjoy music in. You don't need state-of-the-art componentry to enjoy an ambience system. The secondary power amplifiers and speakers can be of very modest perfor-

mance and yet still serve to create strikingly realistic spaciousness in your listening room. If you don't have 2 extra power amp channels on hand, we offer several low cost, low power amps in kit form that would be ideal for this purpose.

Although the 2AS-A has been designed for use in music reproduction systems as an ambience synthesizer, its voltage controlled clock and mixing capabilities allow it to be configured in a number of ways for delay effects such as phasing, flanging, chorus, and vibrato. External voltage control for special effects must be user supplied.

The 2AS-A is sold in kit form only and includes the circuit boards, components, chassis (11½" x 10" x 4"), cover 120VAC power supply, assembly instructions and application notes.

2AS-A Analog Delay Unit
\$250.00 ppd. Cont. U.S.

SWT Southwest Technical
Products Corp.

219 W. Rhapsody, San Antonio, Texas 78216

London: Southwest Technical Products Co., Ltd.
Tokyo: Southwest Technical Products Corp./Japan

MAIL THIS COUPON TODAY

Enclosed is \$_____ or BAC # _____

or Master Charge # _____ Bank # _____ Expire Date _____

NAME _____

ADDRESS _____

CITY _____ STATE _____ ZIP _____

SOUTHWEST TECHNICAL PRODUCTS CORPORATION
Box 32040, San Antonio, Texas 78284

STAFF

EDITOR
Marvin Jones

EDITORIAL ASSISTANT
Jarice Kirkendoll

CONTRIBUTING EDITORS
Craig Anderton
Ken Perrin

GRAPHIC CONSULTANT
Linda Brumfield

PRINTING
"Dinky" Cooper
Semco Color Press

POLYPHONY (ISSN 0163-4534) is published bimonthly at 1020 W. Wilshire Blvd., Oklahoma City, OK 73116, by Polyphony Publishing Co. Entire contents copyright © 1980 by Polyphony Publishing Co. All rights reserved. No portion of this publication may be reproduced in any manner without written permission from the publisher. Controlled circulation postage is paid at Oklahoma City, OK 73125.

ADVERTISING rate card and deadline schedule is available upon request. Contact Marvin Jones at (405) 842-5480.

DEALERS & DISTRIBUTORS bulk prices are available upon request. Contact Marvin Jones at (405) 842-5480.

SUBSCRIPTION rates:

American	1 year	\$8.00
	2 years	\$15.50
Foreign	1 year	\$10.00
	2 years	\$19.50

We now accept MasterCard and Visa payment for subscriptions, back issues, and PolyMart items. Foreign payments must be by charge card, money order, or certified check in US funds drawn on a US bank.

BACK ISSUES are available at \$2.00 each ppd. Send SASE and request our 'Back Issue List' for a complete index of issues and their features, or see the back issue ad in this issue.

CHANGE OF ADDRESS notifications must include your former address and zip code, and any numbers from the mailing label, as well as your new address. When you move, be sure to notify your post office that you DO want second class and controlled circulation publications forwarded. This will save lost or returned issues. Polyphony is not responsible for replacement of lost or returned issues when we have not been supplied with change of address information.

Postmaster, send form 3579 to:

POLYPHONY
PO Box 20305
Oklahoma City, OK 73156
Ph. (405) 842-5480

NATIONAL
ASSOCIATION OF
MUSIC MERCHANTS



CONTENTS

ISSN: 0163-4534

Volume 6, Number 2
July/August 1980

Building and Using a DVCO.....8 by: Tony Lewis

Dream Modules.....24 edited - Marvin Jones

Peter Gabriel in Chicago.....5 by Marvin Jones

COLUMNS & REGULARS

Letters	4
Industry Report	20
Home Recording: Optimum Level Setting	6
by Craig Anderton	
E-Comp Projects: Dynamic Phrasing	28
by Ken Perrin	
Equipment Exchange	30
Advertiser Index	29

ON THE COVER:

Peter Gabriel and Larry Fast In Chicago
Photos Copyright 1980 by Marvin Jones

The trouble with the future is that it usually
arrives before we're ready for it. -Glasow

Bi-Amp Your System

Stereo Active Crossover Kit

- 2-way Symmetrical Filters
- 18 db/octave cutoff
- .01% THD
- 10-30 KHZ response
- High & low frequency gain controls for each channel
- Fixed crossover point 500 or 1000 HZ.
- All parts & hardware included except case.
- To order, send \$89. check or money order to:

AJK ELECTRONICS
P.O. BOX 231
CANTON, OHIO 44701

SPECIFY 500 or 1000 HZ.
CROSSOVER FREQUENCY

\$2.00 for instructions
(Refundable with Kit Order)

WE HAVE THOSE PARTS YOU'RE LOOKING FOR . . .

...and that includes low noise op amps like the 4136 and 4739, CMOS/low power Schottky/and TTL digital parts, voltage regulators, an impressively large — and low-priced — collection of resistors and capacitors, as well as books, tools, Craig Anderton's MusiKits™, computer peripherals, and lots more (including our famous specials). Request our catalogue of parts and kits today; simply send us your name and address, we'll take care of the rest (add 41 cents in stamps for 1st class delivery; orders outside the USA include \$2 to help cover postage and handling costs).

GET- ACQUAINTED- SPECIAL:

If you have a TRS-80™ -I or -II, Apple, Exidy Sorcerer, Heath H89, newer PET, or similar machine, we have the low power, 4 MHz 16K dynamic RAMs needed to expand your memory capacity... and they're only **8/\$59!** Add \$3 for TRS-80 conversion instructions and two dip shunts. At this special price, quantities are limited... SO ACT NOW. *TRS-80 is a trademark of the Tandy Corporation.

TERMS: Cal res add tax. Allow 5% for shipping, excess refunded. VISA/Mastercard: orders \$25 mini call (415) 562-0636, 24 hrs. COD OK with street address for UPS. Prices good through cover month of magazine.

GODBOUT

GODBOUT ELECTRONICS
Bldg. 725, Oakland Airport, CA 94614

LETTERS

Do you think it would be possible for a promoter to stage a 'Jamm style' electronic music festival? How? Where? Who? Ideas?

Chameleon

Sorry to read that Charles Brown is having problems getting Chameleon to run. I'm sure that all of us who've messed with computers have experienced the complete frustration of having a reputedly "good" program repeatedly crash. (I once spent 2 weeks "debugging" a Paia prototype sequencer only to learn that since the program used page 2, it wouldn't run with my 1/2K RAM).

Anyway, I spent last evening comparing my tape dump and listing of Chameleon with the listing published in Polyphony. The code checks, and the program runs exactly like it's supposed to do.

As for Charles' problem, I'd guess there might be some bad bytes in his INIT I routine. Only the VOX # pads call this subroutine. Or perhaps the MUS 1 variables aren't loaded properly. If Charles double checks these points and still has problems, please have him let me know. I'll be happy to send him a cassette dump of the program and the original manuscript listing.

Jon Balleras
4426 N. Damen
Chicago, IL 60625

ADSR Update

In Tim Lawrence's Logic Based ADSR presented in the Jan/Feb 1980 issue of Polyphony, there are a few corrections and additions to aid the constructor. The parts placement drawing shows a jumper between pin 10 of IC 1 and pin 14 of IC 3. The correct jump should be from pin 10 of IC 1 to pin 13 of IC 3. The parts required for this project include MM74C00 for IC 1 and IC 3, CD4066 for IC2, and an LF351 for IC 4. Potentiometer, resistor, and capacitor values shown in the schematic are correct. Sorry for any inconvenience this may have caused.

Tim Lawrence
1934 8th Ave NW
Calgary, AB T2N 1C7
(403) 245-4919

Numan

For those of you who read my story on Gary Numan in the last issue of Polyphony and had a hard time relating the description of the opening number to the song "Tracks", there is a reason. The tune that opened the show was "Airlane". Sorry for the error, and I hope this clears up any confusion.

Kirk Austin
Albany, CA

Interfaces

Your magazine keeps getting better and better. I really liked the idea of the circuit board layout for John Simonton's article on the EKx40.

I'm much into computers and synthesizers, and would like to see some articles that would help me interface/program my own 1802-based microprocessor (or TRS-80 or PET or ...) to control synthesizer modules.

Also, more articles on using the SN76477 or its computer controlled cousin (the General Instruments AY-3-8910/12) would be great.

David Meile
FPO San Fran

Ideas

In response to your request for ideas, I have several projects that I would like to see in your magazine:

- an expander with functions similar to MXR's Dynamic Expander.
 - a parametric equalizer, simple but expandable like Phoenix Systems kit.
 - a circuit that would allow several small mixers to be fed from the same board output so that you could have several headphone mixes.
 - low noise direct box.
 - a condenser microphone power supply circuit for mikes like Shure's SM81.
 - remote control circuits for TASCAM recorders.
 - an electronic timer/clock with large readout in 1/10 seconds and remote start/stop for timing radio spot productions.
 - a telephone answering circuit for two cassette recorders for small and limited staff studios.
- Thank you.

Mike Bailey
Creative Rediffusions
Panama City Beach, FL

Standing up for one's artistic vision is a philosophy often voiced by musicians, yet the tendency to bend with commercial trends has been seen to win out over musicians time and time again. Peter Gabriel is an artist who has had the strength to resist the flow while maintaining progression, experimentation and change throughout his 10 or more years in the business. Strangely enough, Peter's artistic position within the past several years has been such that the commercial music industry is actually going through changes which are putting the new musical drive right smack in the middle of the freeway Gabriel has been driving for the past four or five years. What could better illustrate the phenomenon than the fact that the third Peter Gabriel album (yes, that's the name of this one, too!) shot directly to the number 1 position after its release in England. With a relatively short time in the American market, the album has reached number 34 (Billboard), and many markets are just now beginning to offer the disc airplay. Judging by the sell-out response to Gabriel's recent impromptu swing across America, this album has only a slim chance of not pushing him to the dubious honor of Top Ten artistry. With this type of enthusiasm in the market, it is not surprising that Gabriel's recent tour will not soon be forgotten by those in attendance.

The sound of Synergy's Games was filling Chicago's Uptown Theatre on the evening of June 26, priming the people for the spectacle which they were about to behold. The sell-out crowd

without tears, games without frontiers," as Gabriel turned and walked away. The people were obviously Gabriel fans to the core. Gabriel played on this, and gave them exactly what they wanted. Alternating between his position behind keyboards and center stage, Gabriel went through a number of little dances, rolling on the floor, and crouching, kneeling and sitting at the front of the stage to contact the audience more directly. At one point, he took off at a full speed run-wireless mike in hand, singing all the way—down one aisle, out into the lobby, and back down another aisle, only to jump on stage and finish the song as though nothing had happened. I'm talking ENERGY!

Gabriel's band was nothing less than a spectacular

about the cover...

Peter Gabriel in Chicago

by marvin jones

sitting in the pitch black auditorium started to exude an electricity which is rarely seen at concerts. Many of those in attendance had obviously attended the Chicago stops of the last two Gabriel tours, and they knew it was going to be a devastating evening.

Distant tribal synthesized drums began to appear through the PA, increasing in level over a period of several minutes. Then the spotlights started swarming the audience....but the spotlights were coming from the audience. The band members slowly made their way from the rear of the auditorium, each with his own personal spotlight, searching every corner of the theatre as though they had lost each other in the course of their promenade. Eventually, the band converged on stage, only to be followed by one last fleeting spotlight running through the balcony, downstairs, in one door, out the other, up and down the aisles, and finally Gabriel jumped onstage. The show was off.

Drive. Power. Emotion. Statement. The pace didn't let up for nearly an hour and a half as Gabriel and his band burned through nearly all of the current album as well as many of the more recognizable cuts from the previous albums: D.I.Y., On The Air and Solisbury Hill, to name a few. And in every instance, the rapport with the audience was spellbinding. Typical was the close of Games Without Frontiers, where Peter's mike ended up at front center stage facing the audience while the crowd sang "Games without frontiers, war

background for his compositions. Polyphony readers would, undoubtedly, recognize synthesist Larry Fast, working with his Polymoog, Prophet 5, Minimoog, Moog 15 head, Yamaha mixer, and two racks housing a Harmonizer, AcoustiComputer, crossovers, monitor amps, Bi-Phase, and some home brew digital equipment used as D/A conversion and interfacing from a Paia 8700 which he had programmed to hold all the sequences used throughout the evening. Bassist Tony Levin played the majority of the evening on his Stick, a sight rarely seen; best of all, his mastery of the instrument was superb. Additionally, he switched between a couple other fretless basses, one of which being a prototype of a new 'body-less' bass which looked much like a stripped down Stick. The guitar and drum work was the straight ahead rock foundation for much of the antics of the other three—basic, but omnipresent and solid.

Set production was simple—almost industrial in nature. Columns of sequenced fluorescent lights synchronized with light arrays under the risers. Sets of multiple high intensity spot floods surrounded each individual in addition to the four primary light trees which provided subtle colors and an abundance of stark white light arrays. All members were dressed in matching flight suits, and each had a sequencing circular LED pendant with gave the appearance of some sort of master control receptor/ life support sequencer for the industrial strength entertainment droids on stage.

After an hour of outstanding performance in the uncomfortably hot auditorium, the crazed crowd unrelentlessly demanded a number of encores to which the Gabriel entourage seemed pleased to oblige. All in all, quite an evening. Unfortunately, Gabriel does not tour frequently or extensively. Perhaps that will change with the success he is experiencing with his newly released third album. As a side note, Gabriel recorded 19 songs while he was working on this album. Obviously, they weren't all used on this album, so perhaps we can expect another album relatively shortly. This would surely draw upon the response to the current album and, perhaps, promote additional extended touring in late '80 and early '81. If so, don't pass up the opportunity to see this group of people who relish communicating with their audience.

HOME RECORDING

OPTIMAL LEVEL SETTING

BY: CRAIG ANDERTON

Although the subject of setting recording levels would appear to be pretty simple, there are many subtleties and problems which need to be addressed in order to get the best possible performance out of your home recording equipment. Setting levels correctly can mean the difference between a tape that sounds clean and sparkling, and the one that has a distorted (or noisy) sound. Multitrack recorders compound the difficulties of level-setting; with a 4 track recorder you have to adjust four different sets of levels correctly, and with a 24 track recorder you can screw things up 24 different ways! Additionally, there are other factors to consider when deciding what record level is most appropriate, such as the leakage between tracks, pre-emphasis built into the recorder electronics, the type of tape that you're using, and so on.

In this column, we'll first look at why level setting is so critical. Then, we'll discuss some rules concerning the setting of levels that should help you improve the overall sound of your tapes.

THE BASIC PROBLEM

The basic problem is very simple: live music has (for all practical purposes) an infinite dynamic range. The difference in sound levels between a snare drum crack at full volume, compared to the sound of a snare drum "at rest", is huge. Even an instrument such as the guitar has a tremendously wide dynamic range; and the human voice, of course, can go from a shout to a whisper.

Tape recorders, on the other hand, have a very limited dynamic range. There are two basic bottlenecks that limit this range. The first bottleneck is the electronics used in the recorder, although with modern circuit design techniques this is no longer much of a problem. Instead, we run into the next bottleneck, which is the dynamic range limits of the tape itself.

The tape's dynamic range is constrained at the low end by noise and hiss inherent in the physics of tape construction. Add this to the noise of the electronics used in the tape recorder, and you've already made it difficult to capture extremely weak or soft audio signals.

The maximum dynamic range that a tape can handle is dependent on its saturation characteristics. While tape has no problems accepting signals up to a certain level, past that point distortion increases rapidly with increasing signal level. If you're used to the standard clipping sound associated with solid state equipment (where the onset of clipping is rapid and obvious), tape distortion comes as quite a surprise. One experiment that will help familiarize you with tape distortion characteristics requires nothing more than a low distortion sine wave generator and a set of headphones. Plug the generator into the tape deck, monitor off the playback head, and slowly increase the generator's output. You'll note that the distortion will remain comfortably low until a certain point, and that past this point the distortion will increase. Putting on more and more level just gives more and more distortion, along with a phenomenon known as modulation noise. This is an envelope of noise that appears in conjunction with strong levels on the tape; it sounds like regular noise although much louder since it appears to be "riding along" with the strong signal.

The useful dynamic range of a tape recorder lies between the noise floor and the maximum acceptable amount of distortion. The latter is a bit hard to pin down, since different amounts of distortion are acceptable to different people; many tape deck manufacturers arbitrarily use 3% distortion as an indication that the upper dynamic range of the tape recorder has been reached.

With cassette recorders, the total dynamic range may be as little as 50 to 60 dB - and when you're trying to fit music with a dynamic range of 120 dB onto a cassette, you can see where this might cause difficulties. Noise reduction systems can help push the dynamic range into the 65 to 70 dB category, quite an improvement but still nowhere close to the real world. Professional analog decks start at about 60 dB, and some of the better ones can exceed 70 dB without noise reduction. One of the promises of digital recording is extremely wide dynamic range, starting at 90dB and getting better from there.

In a way, you can think of level-setting as a "funnel" that has to

funnel real world dynamics down to the very limited dynamic range of the tape recorder. If levels are set too low, then the noise will become more apparent, and you will not be taking full advantage of the tape recorder's dynamic range. Setting the levels too high, however, means that you'll get distortion. The object of proper level setting is to make sure that your signal always exceeds the noise floor, but doesn't exceed the maximum tolerable distortion.

GENERAL RULES ABOUT LEVEL-SETTING

RULE #1: YOU CAN'T TRUST VU METERS. VU meters represent an average signal level. Feed a 2V p-p sine wave into a VU meter, and you'll get one indication; change that signal to a 2V p-p 5% duty cycle pulse waveform, and the meter reading will drop drastically...yet, in both cases the input signals have the same dynamic range.

Peak indicators are very helpful, since they can show the maximum dynamics of an input signal. Peak indicators in conjunction with meters are most helpful of all; if you have high peak readings and low average readings, that's a clue that you need to add some kind of limiting or compression. If you have a signal that reads +8 or so on peaks and whose average level lies around -5 to 0 on the VU meter, then you know that you aren't banging the recorder hard enough to cause significant distortion, yet the average signal is high enough so that noise should not be a problem.

RULE #2: TREAT TREBLY SIGNALS WITH RESPECT. All tape recorders include pre-emphasis, which boosts high frequencies as they go into the tape recorder. Tape has a hard time coping with high frequencies, so this boosting helps make the tape's job easier. However, this also complicates matters somewhat in that a signal with lots of high frequency energy will overload a tape recorder much more readily than a predominantly low frequency signal. For example, try recording a tambourine at 0 VU on the meter, then record a bass at the same level. On playback, the tambourine will appear far louder, may be distorted, and will also probably leak on to adjacent tracks of the

recorder. Between the natural excess of high frequency energy present in a tambourine, coupled with the percussive nature of the instrument which gives a deceptively low average reading on the VU meter, you'll have to set your levels far differently from the way you would set them with a non-percussive, low frequency instrument.

RULE #3: THE HIGHEST POSSIBLE LEVEL IS NOT ALWAYS THE BEST LEVEL. While it seems that the higher the recording level the better, there are a couple of complications. For one, a high recording level is more likely to cause print-through problems when the tape is stored. Print-through occurs by interaction between the magnetic fields on adjacent layers of tape; higher recording levels mean stronger magnetic fields, which increases the chances for interaction. Excessively high levels can also lead to leakage between tracks. For example, if you record something trebly on track 2 at a very high level, the odds are excellent some of those highs will spill over on to tracks 3 and 1 (and maybe even track 4). As a result, cymbals, some fuzz guitars, percussion toys, and similar high-energy/high-treble content signals should be recorded at a considerably lower level than the VU meters might lead you to believe.

RULE #4: LEVEL SETTING IS NOT A STATIC PROCESS. Part of music lies in its dynamics; it's important to preserve these dynamics in any recorded performance. However, the limits of the tape recorder might work against you - as a passage gets softer, for example, the noise might become obtrusive. Your

best bet is to ride the level control so that during quieter passages, you bring up the signal level a bit. While this inhibits the dynamics, try to think of it as a temporary "fix" (after all, in the mix you can restore some of the missing dynamics). Sound clumsy? Well, it is...but certain compromises must be made during the recording process, and this is one of them.

RULE #5: LIMITING AND COMPRESSION CAN BE VERY HELPFUL: Many people feel that limiting and compression are "bad" because they restrict dynamic range. Well, the tape recorder's going to do it anyway, so you might as well use limiting and at least have some control over the process.

Incidentally, if the limiting action is sonically obvious you're probably using too much limiting. You should take all possible steps to avoid the use of limiting while recording; then, you can add limiting as a sort of "safety valve" to catch only the highest, most bothersome peaks. This will leave the sound virtually unaffected.

RULE #6: DON'T BE AFRAID TO USE TAPE LIMITING. The saturation effects of tape can be used to good advantage. With guitar, for example, there is a sudden transient that occurs when a note is first plucked. The amplitude of this transient is far greater than the average signal level; if you set levels to accommodate this peak, the rest of the guitar signal may end up at too low an overall level to give good noise performance. While limiting can help, you can often use the saturation characteristics of the tape to "hard

clip" the transient. This gives a more natural sound than electronic limiting (many tube amps perform a similar type of clipping with guitar signals, whether you want them to or not), and the distortion is of such short duration that it isn't really objectionable.

Another case where tape limiting has proven most useful to me has been with electronic drum units, since these normally have an overly clean sound. Cranking the record level up so that the drum peaks are heavily distorted gives a more complex and satisfying type of sound. I think part of the reason why this sound is subjectively more pleasing is that with traditional percussion instruments, we're used to seeing a drummer flailing around and getting all worked up in a highly physical manner. Electronic drum units don't have to work hard at all - so by cranking up the levels, we at least know that the tape is sweating and working away. Incidentally, the effect just described cannot be simulated with fuzzes or similar electronic distortion units. The sound of tape saturation is much more gentle, and lacks the harshness associated with electronically induced distortion.

The one disadvantage of using tape saturation techniques is that it drastically increases the possibility of leakage problems between adjacent tracks. If you're going to record a track at an exceptionally high level in order to produce a saturation effect, it had better be the first track on the piece of tape. Otherwise, it will leak

Continued on Page 18

serge
MODULAR MUSIC SYSTEMS

LEVEL 8

LEVEL 12

NEW : LEVEL 3

- MODULAR
- AFFORDABLE
- STUDIO QUALITY
- PRECISE •
- COMPATIBLE •
- ULTRA-VERSATILE •

572 HAIGHT ST. • SAN FRANCISCO, CALIFORNIA • 94117 415-621-6898

Build a DIGITAL VCO!

by Tony Lewis

Once upon a time those few who could afford synthesis equipment were happy with VCOs that produced only a ramp. One day somebody added a comparator and got a square wave. With more circuitry, things like triangle and sine waves appeared and that is about where it stands now - the "basic four" waveforms in synthesis. Well, no more!

Here is a VCO that will produce ANY waveform and can be built for about the cost of a "basic four" VCO. Think for a moment of the advantages of having any waveform available.

1. You need only one VCO to produce the "tracking oscillators" type of sound.

2. Since the waveform's harmonic structure and overall amplitude can be controlled in real time, VCFs and VCAs become unnecessary in some situations.

3. You can create waveshapes on a piece of graph paper.

4. With a fast A/D, you can load the waveform of a sound you hear into the VCO.

I realize that some of these things sound a little far out and hard to understand now; more on these later. While I'm at it, I should mention the faults.

1. It must be interfaced to a computer.

2. The current range is from 30 Hz to 8 KHz; it is easy to extend this range.

3. It has a slight amount of quantization error. (When quantizing a continuously varying waveform, you generate a set of numbers representing the original. These discrete numbers result in the representation being a series of stairsteps unlike the original. This is quantization error.)

First let's discuss what the DVCO is and how it works. We will then see how to build one. Best for last - how to do some of the effects I have mentioned.

Theory

The basic idea behind the DVCO is to store a digital representation of the desired waveform in memory and clock the data out to a D/A for conversion to a discrete voltage. This varying voltage is the output waveform with one complete cycle through memory being one cycle of the waveform. The frequency of the output waveform is controlled by how fast the data is clocked out of memory. Refer to Figure 1 for a diagram of this process. The high frequency VCO (HFVCO) is used to clock a binary counter at a rate determined by a control voltage. The output of the counter is used as the address input to a random access memory (RAM). Since the counter is constantly counting up by one each clock cycle, the RAM is really used as a sequential access memory. This is the basis for the entire concept, as the data in the memory now comes out in sequential order and is converted to a voltage by the DAC. The output filter is used to smooth the voltage steps which make up the waveform (i.e. reduce quantization error).

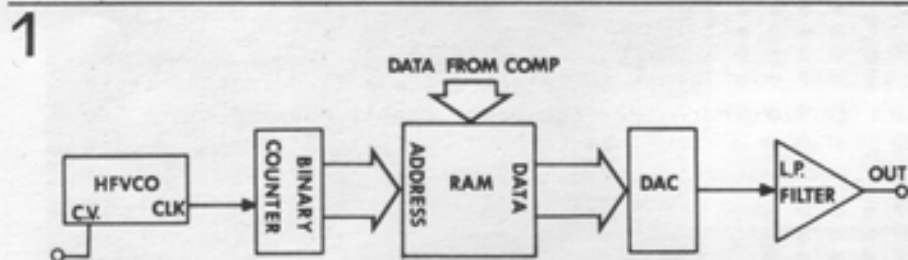

How It Works

The block diagram that you have been looking at could almost pass for the schematic; that is really all there is to it (honest!). The real schematic looks more complex because of all the connections (like data and address lines) that you have to draw as separate lines instead of one big arrow. Let's look at the digital section first (Figure 2). The two rectangles on the left are 74C93 CMOS binary counters. These make up the address counter we drew as one block in Figure 1. Two counters are needed because each IC is a four bit counter and there are seven address lines. Notice in the power connections table that pins 2 and 4 of the 74C93s are

grounded, and also pin 1 in the schematic. The reason I did not include pin 1 in the table is that the counters can be reset to zero by bringing pin 1 high. In an expanded version of the DVCO you can phase sync the output to an external signal using this reset feature.

At this point the reader should realize that the DVCO can be placed in two modes of operation: free running for normal operation, and computer control to change waveforms. This is why the HFVCO is not connected directly to the clock input of the counter. When the computer is trying to load new data into memory it would not want the memory address to count at some unknown (to the computer) rate; when the computer takes control of the DVCO the gate labeled 'A' above the counters is turned off (called Tristate mode, which means the output of the gate exhibits high impedance to the outside world). This disconnects the HFVCO from the counters and allows the computer to clock the counters on command using gate 'C' which is part of a CMOS CD4016.

Now that the address is supplied to the memory, it needs a few timing signals to get things right. To start with, it needs to know if data is being written to it from the computer or read from it. The R/W line does this. When the computer is in control, gate 'A' (the one above the RAM) is on and the computer's R/W signal is passed to the memory. When the DVCO is in the free running mode, the gate is in tristate and R2 pulls the line high corresponding to a read operation.

While the R/W line is telling the memory what to do, the $\phi 2$ line tells it when. The switching of this line is just like R/W; so, I won't go through it. The line feeding memory pin 10 (cs0) tells the memory when the computer wants it to accept data (something like R/W). The cs0 line's switching is like the previous two except it employs a diode 'AND' gate (R5 is part of this gate).

See Table 1 for a summary of control line status.

Later, we will see how you get the DVCO in one mode or the other but for now let's assume that it is in the free run mode. As the counters increment the address lines, the data corresponding to each address appears (in sequential order, remember) on the data lines. The 74LS367s are unidirectional (one way data flow) tristate buffers connecting the computer and memory data lines. Since we said the DVCO was in the free run mode, these buffers are tristate so data coming from the memory never sees them. All that must now be done to the data is buffer it with the CD4050 - a CMOS device. CMOS was used here as the output swings fully from ground to Vcc unlike TTL, and this is important for accurate D to A conversion. The output of the buffers directly feed the resistor ladder network which is the D/A. The D/A is completed by the op-amp used in the inverting configuration. This means that your digital representation in memory will turn out inverted. For example, if the data in memory was for a 30% duty square wave, the inversion (ie. 70% duty cycle) would be the output. If this is objectionable, a unity gain inverter can be placed on the output of IC11.

Now that we see how the main output is produced, there is an auxiliary output available. Notice at the lower left hand corner of the schematic the output labeled "8va down square out." This is the buffered output of the highest order bit of the eight bit counter. This provides a 50% duty cycle square wave which is half the frequency of the main output waveform (assuming that only one cycle is stored in the memory).

Pin	Signal	Status	
		Computer Control	Free Run
16	R/W	R/W from comp.	+5
13	CS3	$\phi 2$ clock from comp.	+5
10	CS0	High only when IO#=0, RS0=1, RS1=0.	+5

Table 1: Control Status

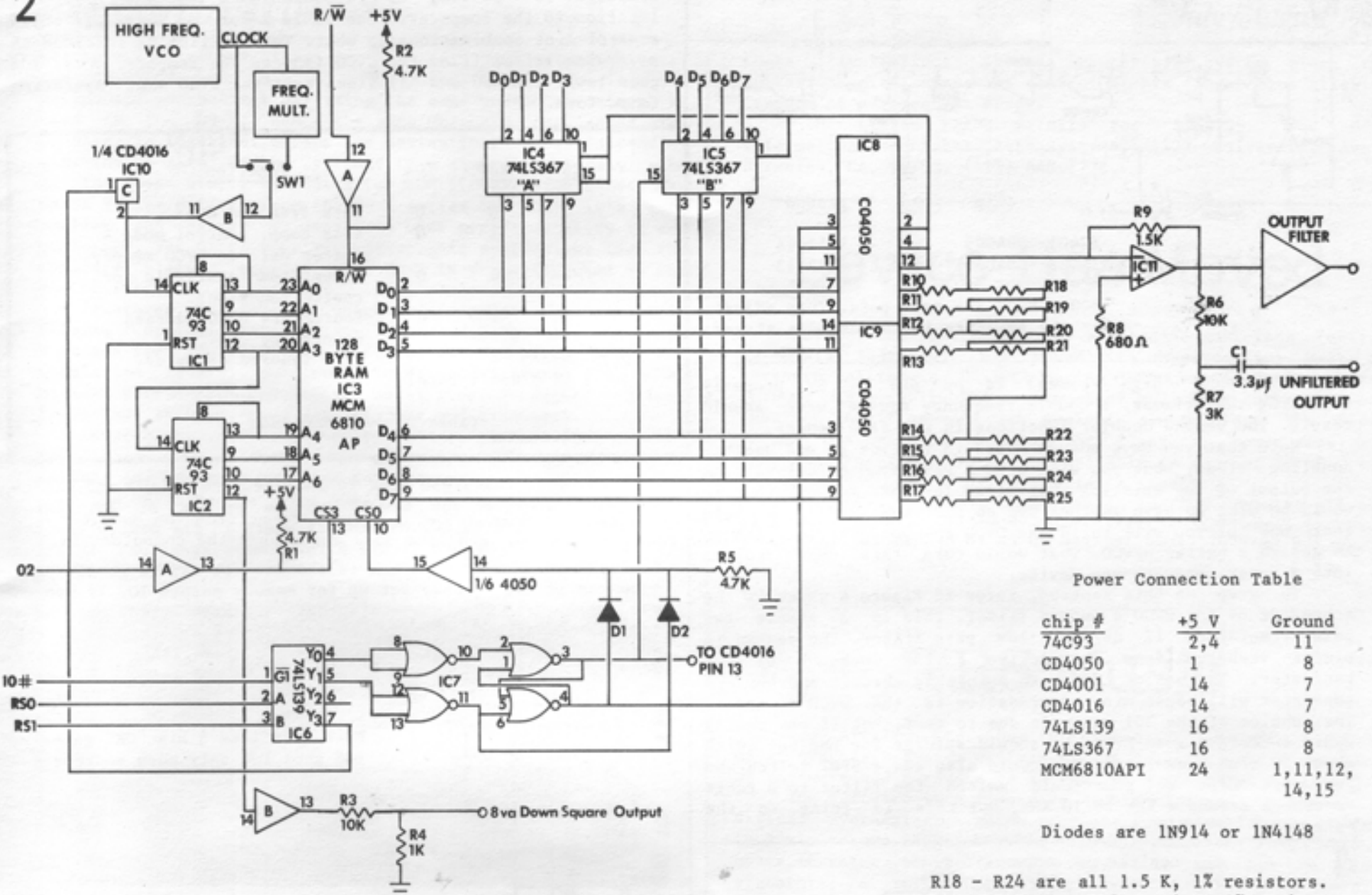

Power Connection Table

chip #	+5 V	Ground
74C93	2,4	11
CD4050	1	8
CD4001	14	7
CD4016	14	7
74LS139	16	8
74LS367	16	8
MCM6810API	24	1,11,12,14,15

Diodes are 1N914 or 1N4148

R18 - R24 are all 1.5 K, 1% resistors.
R10 - R17 plus R25 are 3 K, 1% resistors.

NOTE: denotes part of 74LS367 except where otherwise noted. Letter ID indicates which package.

Essential to the operation of the DVCO is the HFVCO. Refer to Figure 3 which is the schematic of the HFVCO. I suggest that you also dig up the reference mentioned in the schematic notes, for it does a good job of "evolving" a circuit that is quite similar. (See "Lab Notes", Polyphony, November 1977, pp 28-9.)

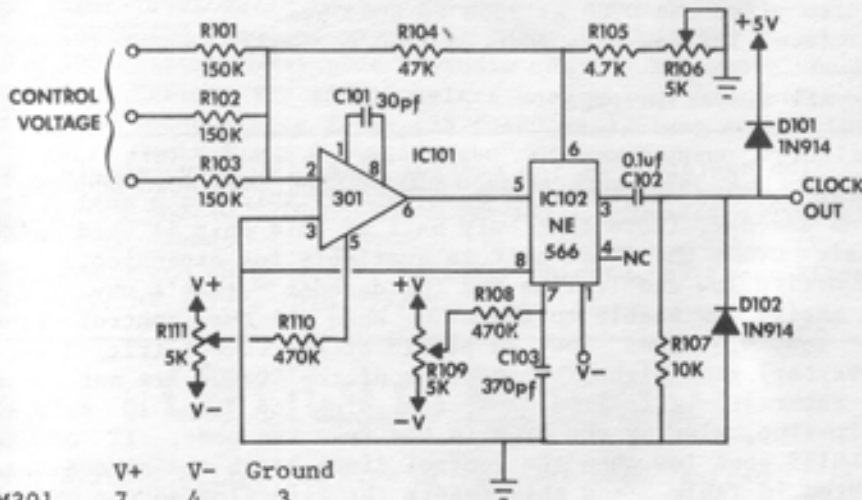

	V+	V-	Ground
LM301	7	4	3
NE566	nc	1	8

Notice that NE566 power connections are a little unusual. See Polyphony November 1977, pp 28-9, for analysis of a similar circuit.

Notes: R119 and R111 are 10 turn trimpots.
R106 is front panel range control (Use 10 turn pot if available).
All pin numbers assume 8 pin mini-DIP package.

The NE566 is a VCO chip which is rigged in an odd configuration - here I will only mention the differences

between my circuit and the one in the reference. To get better linearity and wide range I have employed a 301 type op-amp so an offset adjustment could be added.

R109 and R110 form a simple current source which cures a problem inherent in the 566. I did not find the elaborate current source used in the reference necessary here.

R104 sets the control voltage range; I have it set to a five volt swing. If you want to try for more range with a five volt input, try increasing R104 (but you might run into linearity problems). If your control range is zero to ten volts, change R104 to half of its present value. D101 and D102 are to insure that the clock output will not go below zero or above five volts since the clock feeds a TTL circuit. It is important to note here that the power supply must be close to ± twelve volts for the clock to be of sufficient amplitude for the rest of the circuitry. If you insist on using ± nine or some other supply, you can add an amplifier to the clock output. If this is done, put the diode clipping circuit on the output of the added amplifier and remember that the amp must have a high slew rate due to the frequency at this point sweeping past 1 MHz (which would be a little less than eight KHz on the DVCO output). If you do add an amp and want to calculate your maximum clock frequency, multiply your maximum audio output frequency by 128. This assumes that the frequency multiplier is switched out of the circuit (SW 1 in Figure 2).

To improve HFVCO linearity over earlier designs, the timing cap was increased which lowered the frequency range. To cure this, a frequency multiplier has been added to the HFVCO output with a switch to select the multiplied clock or the 'straight' HFVCO output. See Figure 10 for the multiplier schematic.

The circuit is nothing more than two frequency doublers. The first XOR gate at the input is a non-inverting buffer which feeds the first doubler. The RC network shortens the 'high' time of the pulse train. The normal pulse train shows up on pin 1 of the XOR, and the same in-phase pulse train (but

Construction

I recommend that you wirewrap the digital section (including the resistor ladder in the D/A, but not the op-amp). The reason for doing this is two fold:

1. Making a PC board would be fairly time consuming and difficult.
2. This is the type of circuit you just can't resist tinkering with and this is easily done if constructed using wire wrap.

It would not hurt to breadboard the HFVCO and output filter because these have the same "tinker appeal" and there is a lot that could still be done (particularly to the HFVCO) to improve the DVCO's performance.

Construction of the digital section is rather straightforward, but if you have never wire-wrapped before, it would not hurt to practice. Figure 6 is a top view layout of the digital section on perf-board (remember this is not law - just my suggestion). After the digital section is wire-wrapped you should apply ground and +5V with NO CHIPS in the sockets and CHECK THE VOLTAGE AT EVERY PIN. This will avoid damage to any of the ICs if there is a wiring error.

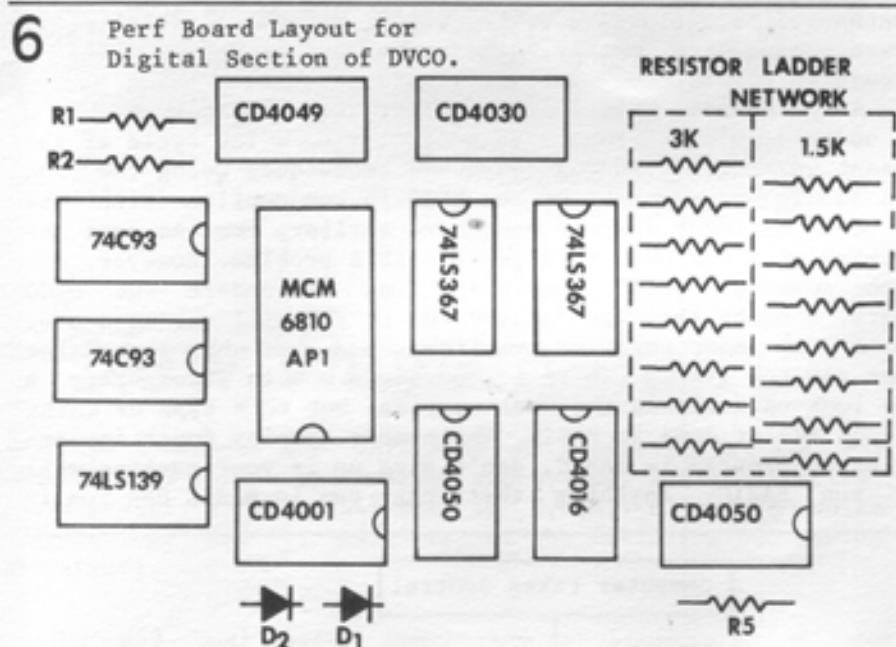

In building the HFVCO and output filter, do NOT substitute ceramic caps for any marked as mylar or polystyrene in the parts list. Also, if you decide to put these circuits on a PC board, it is important that you clean the board after soldering. The rosin can cause impedance problems (particularly frequency drift in the HFVCO).

Almost any source of ± 12 volts can be used to power the DVCO; I recommend that it be regulated for least oscillator drift. The +5V can usually be derived from the +12V supply using a 7805 regulator. Note that this regulator can supply up to one amp of current if the +12V line can. So, the DVCO power supply could handle some outboard equipment if needed.

Testing & Calibration

Once you get the separate sections of your DVCO assembled, I recommend the following test procedure:

1. Leave the HFVCO disconnected from the digital section and also disconnect the current compensator (disconnect the end of R109 going to C103). Apply power to the HFVCO only.
2. Apply your oscilloscope probe to TP1 and ground the CV inputs. You should see no waveform - only pure DC at about -8 volts (voltage not critical).
3. Leave the scope connected and apply 2.5 volts to one of the control voltage inputs. Now you should see a triangle wave at TP1. The frequency is not critical yet. Try varying the CV and note that you can see the wave at any CV from five volts down to within a few millivolts of zero.
4. Set the CV to the minimum that still produces a waveform (a warped looking triangle) and connect the current compensator after setting its pot to center. Don't be alarmed if the wave dies. Adjust the pot until the waveform returns

and, if it won't, increase CV until it does. Once your waveform is back, adjust the pot to get the best looking triangle wave at a low frequency.

5. Move the scope probe to the clock output; you should see a square wave that is switching close to +5V and ground. If things have gone OK up to now and there is no clock, check to see that you have some CV applied and that D101 and D102 are installed correctly. If the clock doesn't make it to five volts, it may be fine. Just be sure it is between ground and .7 volts when low and between 2.5 and 5 volts when high.

6. To calibrate the frequency multiplier section, apply the HFVCO output to the doubler input. Be sure you have completed calibration on the HFVCO, and apply your maximum control voltage to it. Put your scope probe on pin 3 of the XOR and adjust R401 for the most symmetrical 2X square wave you can get. Now, place the scope probe on pin 4 of the XOR and adjust R402 in a similar manner; the frequency should be multiplied 4X at this point.

That's it for test and calibration of the HFVCO. There is no calibration for the output filter (unless you want to put a graduated scale on the cutoff frequency pot). Check the output filter by applying a 10 KHz sine wave to the input of the filter; check that the output amplitude falls as the input frequency is increased.

The time has come to tie all of the sections together and see if it works. When making connections to the computer, be sure the computer ground gets tied to the DVCO's ground. Assuming that nothing is functioning as an SED (smoke emitting device), run a program which turns control over to the DVCO (free run mode). See software section of this article for details on the programming.

Check the voltage at pins 3 and 4 of the CD4001 to make sure the DVCO is in the free run mode (pin 3 low, pin 4 high). Now put your scope probe on pin 2 of the CD 4016 and you should see the clock, assuming a CV is applied to the HFVCO. If not, it is one of three things:

1. The clock coming from the HFVCO is not at the right level for the TTL circuitry.
2. The switching circuits for the clock (part of a 74LS367 and a CD4016) are not wired properly.
3. The DVCO is not in the free run mode.

Once you have a clock signal at the CD4016 pin 2, check to see if there is a square wave on the "8va Down" output. The presence of this signal is a good indication that the address counters are wired properly. If there is no signal, trace back through the circuit to find the problem.

If you are OK to this point, put the scope probe at the unfiltered output of the DVCO. Here you should see a pattern similar to white noise. This is caused by the random data that is written into memory on power up. If you see this pattern, your DVCO is at least fine in the free run mode. If not, check to see that there is random data coming out of the memory.

A wiring error in the control circuits could cause the memory to be in the disabled state (data lines go tristate). This can be checked by seeing if all three enable lines are high in the free run mode. When troubleshooting the circuit, remember that much of it is MOS and is sensitive to static discharge.

Once your DVCO works in the free run mode try loading a waveform into it from the computer. If you have difficulty, check the following:

1. A ground line from the computer to the DVCO must be present.
2. In the computer control mode, be sure that pin 1 of the 74LS376s are low (data buffers enabled). Also check the three memory enable lines for correct signals as per Table 1.
3. Excessively long (greater than four feet in most cases) cables between the computer and DVCO can cause "ringing" in the data lines which will result in incorrect data (or none at all) getting to the DVCO.
4. Be sure that your software is running properly.

Once you get a programmed waveform to appear at the unfiltered output, try the filter output to ensure it is working.

This concludes the theory/construction/testing of the DVCO. If you are having problems getting your unit to work the way you think it should and are stumped, don't feel bad; it is a complex circuit. Feel free to contact me if you are stuck; I'll try to help.

Software

The first step in learning to use the DVCO is to get a waveform programmed into it from the computer. Before going into detail let me explain a few things about this section of the article. In order to make the DVCO software as versatile as possible, the machine language programs are expressed in flow charts. This makes it possible for users with different CPUs to use the software with minimal changes. The other thing to point out is the notation used. All memory addresses are in hex and the word "address" is abbreviated "addr". "Acc." refers to any 8 bit CPU register that can be used as an accumulator.

The first thing to remember in using the DVCO is how the computer controls it. Three rules for this are summarized in Table 3. When using these rules remember that the 'take control' function also serves as a 'write to memory' command. Note that it doesn't matter what data is written to the DVCO for a control function, but it obviously does matter what data is written to the DVCO when actually programming a waveform.

To take control, write to 2nd DVCO addr
(8001 or 0001 in my examples).
To set free run, write to 1st DVCO addr
(8000 or 0000).
To inc DVCO addr, write to 4th DVCO addr
(8003 or 0003).

The write operation can be done as a "store acc"
to the desired address.
The data stored is irrelevant for control.

Table 3: Three Rules For Using The DVCO

The first program we will look at is diagrammed in Figure 7 and the actual program is in Listing 1. (I list this programs assembled source code for example and not to show favoritism to one or the other CPU.) When studying this program, trace the flow in the chart and then look at the source listing to see how it is implemented. Note that the program listing is in 6800 source code which is similar to that of the 6502.

The program first takes control of the DVCO by writing hex 00 (remember that the value of the number written is not important yet) to addr. 8001. The length counter that is set up next is used to keep track of how many bytes have been written into the DVCO memory. If you are wondering, 80 hex equals 128 in decimal - the number of bytes in the DVCO memory.

The next step is to write the first byte of data into the DVCO (by virtue of the DVCO design, this first byte has already been written to memory but it is convenient and easier to understand the program if we go ahead and write the data in again.) Each time through the loop the program comes back to this point to write the most recent byte of data to the DVCO. Now the program must increment the DVCO address counter so the data goes into sequential memory locations. After this, the program decrements (subtracts one) from the length counter to signify that there is one less addr. in the DVCO memory that must receive new data. The program must then decide if all of the memory locations in the DVCO have received new data. If they have not (length counter not equal to zero) as in the case of the first time through the loop, the program goes to a routine that calculates the next byte of data. Notice in the source listing that this routine is located outside the main program so it can be changed without moving the entire program. In an expanded version of this program it would be a good idea to make the nval routine into a subroutine. In the source listing there are two versions of nval listed - one for a ramp and the other one for a square wave. Notice that the ramp version calculates the new data based on the previous data while the square wave routine uses the distance through the memory to calculate its result. After 128 times through the loop, the program will return the DVCO to the free run mode and the user has the waveform he programmed available in his DVCO.

By this time you have probably realized that even this simple machine language program can produce a wide variety of waveforms using the nval routine. The following are a few of these:

1. Using the ramp version of nval, add another INC A to it. This will double the amplitude of the ramp produced. A third INC A will generate 1.5 ramps per cycle of the waveform.
2. Using the square version of nval, change the data in memory location 0117 (the data after CMP B). Since this number controls how far through the data the program starts setting ACCA to zero, it has the effect of controlling duty cycle. Remember when experimenting with this that the output waveform is inverted from its digital representation.
3. Try writing your own nval routine. (Suggestion - try incrementing ACCA until half way through the data and then start decrementing ACCA. This should produce a triangle wave. Now try to vary the duty of the "ramp up" time of your triangle, etc.)

When using this routine, notice how fast it can load the DVCO. If you want even more speed, change the program we just discussed so it will store the calculated data in a memory matrix instead of directly in the DVCO. In this way you can set up several such "waveform matrices" and change waveforms seemingly instantaneously.

Using this technique of storing waveforms in the computer, you can simulate a VCA or VCF on the output of your DVCO. For example, with a set of waveforms stored in memory which are all of the same waveshape but of decreasing amplitude, you can send these matrices to the DVCO (using something like a block move routine) with a little delay between each new matrix, and come out sounding like a percussion envelope on whatever waveform you were using.

As it stands, this is a crude technique in that the DVCO is updated without regard to where it is in the cycle of the present waveform. With some advanced techniques using the '8va down square wave output' of the DVCO in conjunction with the now dormant reset feature mentioned earlier, you can sync the software with the DVCO to alleviate this problem. However, due to the computer still requiring time to update the DVCO memory, I doubt that the "ghost" VCA or VCF will see much use.

I can hear sceptics mumbling, "Yea, but what about sine waves and the like." There is no reason not to incorporate a sine look-up table in the nval routine, but this type of thing is much easier done in BASIC. While more complex functions are easier to program in BASIC, don't give up if your machine will not run BASIC. Anything that can run in BASIC can run in

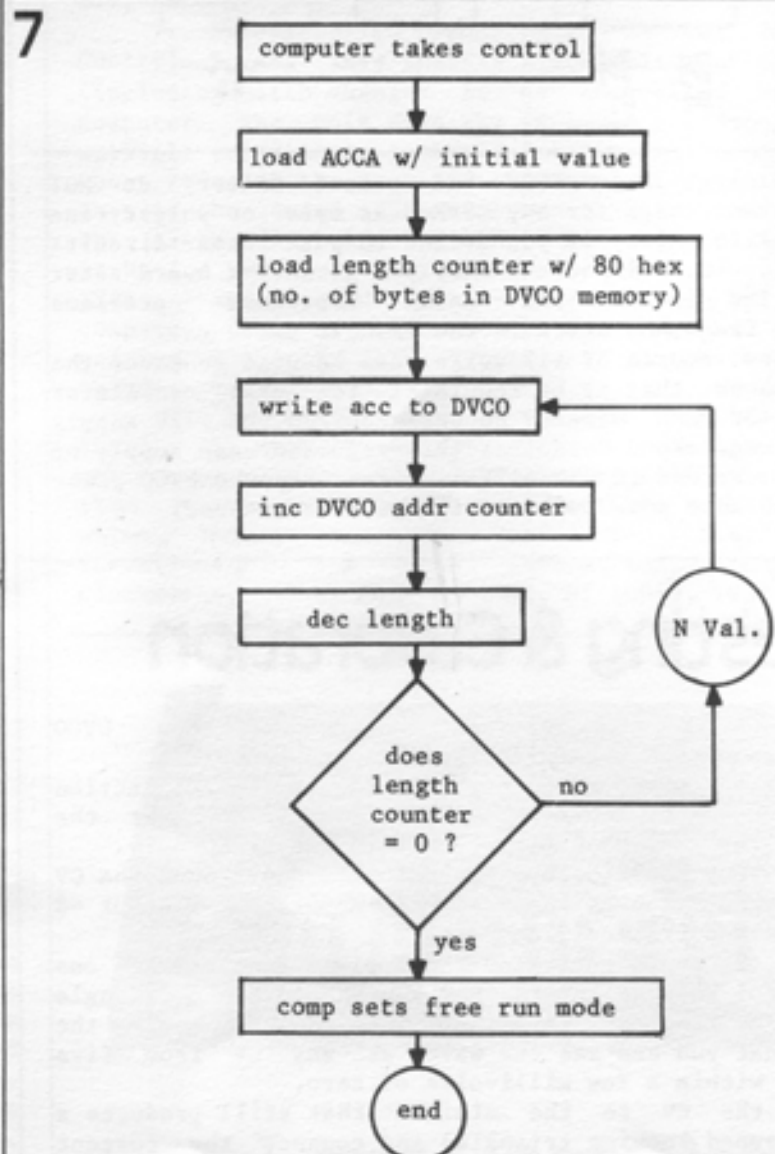

machine language with greater speed and less memory. It just takes a bit more effort to write the original program. (Anybody out there who's machine will run FORTRAN has really got it made.)

The time has come to generate some sine type waveforms and, since we are moving from machine language to BASIC, I had better make this statement now. At this point the use you get out of the DVCO will depend directly upon your mathematical skills and creativity. Now please don't let me scare anyone off - I mean if you have gone this far you might as well go all the way.

All of our waveform generation in BASIC revolves around one basic program (no pun intended). This program can be used to generate most any class of waveform including those based on trigonometric functions and the Chebychev series of polynomials. Let's first concentrate on trig. based waveforms; before we look at the actual program, let's have a quick refresher on basic trig.

In any trig. function there are three basic things that you can control by changing numbers - frequency, amplitude, and phase. Take for example the equation $Y=A \cdot \sin((X+P) \cdot F)$. The coefficient A controls the amplitude of the sine wave and, when A=1, the Y value varies between -1 and +1 as X varies from 0 to $2 \cdot \pi$ radians. (Note - All angles will be expressed in radians instead of degrees since many versions of BASIC compute angles only in radians.) The variable F controls the period of the sine wave and therefore the frequency. When F=1 the period is $2 \cdot \pi$ and the relative frequency would be one. Notice that as F increases, the period decreases and the frequency increases. The variable P controls the phase shift, with P=0 corresponding to no phase shift. Note here that a positive P shifts the wave in the negative direction. See Figure 8 for a summary of the effect of these variables.

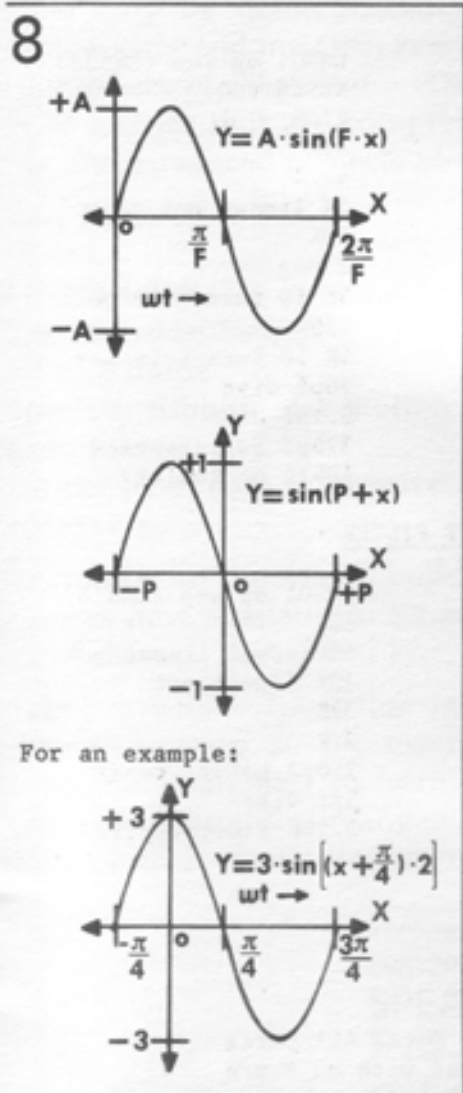

By altering the three basic parameters of a trig equation one can produce an infinite number of waveforms. For example, suppose you desired a waveform containing, obviously the fundamental, the third harmonic at one half the amplitude, and the fourth harmonic at one third the amplitude. It would take three VCOs that tracked quite well plus a mixer to do this, but with the DVCO in operation we could use the equation $Y = \sin(X) + \frac{1}{2} \sin(3X) + \frac{1}{3} \sin(4X)$ to generate the function. From this example it should be obvious how the user could generate a waveform with any harmonic spectrum he desired. Even though the more complex equations require some time for BASIC to compute, once the computation is done the user could save the waveforms he liked (i.e. the data representing the waveforms) in a matrix in memory or on tape.

Now that we see just how versatile trig functions can be, let's look at a BASIC program to generate them (see Listing 2). This program can be broken up into three sections. The first section is a FOR NEXT loop which steps the variable X from zero to two pi radians and uses this X to calculate the corresponding Y based on an equation supplied by the user. This section also watches for the maximum (variable M1) and minimum (variable M2) Y value. This data is used by the next section to scale all of the Y values so they are between 0 and 255. This must be done since 0 to 255 is the range of numbers that can be expressed in an 8 bit byte and each word in the DVCO memory is 8 bits wide. The third section takes control of the DVCO and transmits the scaled data to it. The program then sets the DVCO into the free run mode so it is available to the user.

No flow chart is provided for this program, for it is abundantly commented and relatively straightforward in its

operation. Note that the print statements are for user convenience and can be eliminated to speed execution.

One thing I should mention about the scaling section of this program is that it can do seemingly funny things to functions whose range of Y values is quite wide. Take for example the function $Y = \tan(X)$. See Figure 9.1 for a graph of this function as it would be normally. Notice that at $\pi/2$ and $-\pi/2$ the function becomes undefined (goes into infinity). Now, remember that the Y values the DVCO actually sees must be between 0 and 255. In other words, there is a very finite range of values (256 to be exact) that we can use. Also remember that the scaling routine must make all of the Y values for any given function fit in this range. To see the effect of this, look at Figure 9.2 - this is the waveform that actually gets loaded into the DVCO after the scaling routine. When the scaling routine fits an infinite value into the finite range, all of the finite values to be scaled end up having an absolute value less than the least significant bit (i.e. the finite values are forced to zero due to the presence of relatively infinite values).

There are several modifications we can perform on Listing 2 to deal with polynomials instead of trig functions (we really could combine them for that matter). About all that must be done is to set it up so the X values are generated over the desired interval for the particular polynomial being evaluated. For example, the polynomial $Y = X^2$ is a parabola on any interval that is centered around zero, but is a power function ramp on any interval that does not cross zero. To set up the desired interval, you must alter the FOR-NEXT loop on line 30 of Listing 2. When setting up new parameters for the loop, remember to also alter the STEP on line 30 so 128 successive X values will be produced.

The easiest way to use polynomial functions is to sketch a proposed function on graph paper and select the interval desired. Speaking of graph paper, if you can visualize a waveform and are just dying to hear what it sounds like, draw it on graph paper so one cycle is 128 squares long and the amplitude swings over about 256 squares.

It should be no problem reading the numbers from your drawing to enter in the DVCO. While hand entering 128 numbers just to get one waveform may seem like a lot of work, it is often well worth the effort. (Warning - It may be harmful to your sanity to forget to save on tape the data for a waveform you just spent half an hour creating.) You may be surprised how changing just one number can radically affect the resulting waveform, so give this branch of the DVCO plenty of experimenting time.

The next trick probably isn't too practical for many of you yet, but I'm working on changing that. When was the last time you spent hours trying to patch up a realistic trumpet or cat's meow or some other sound you wanted to imitate? With one other piece of equipment, the DVCO can be a big help in this type of work. The catch is the other piece of equipment - a fast A/D. Not many people have A/Ds on their computer yet, let alone one fast enough for digital recording. However, all is not lost for a relatively simple (and very fast) A/D is under development and may be forthcoming in another article.

Basically what you do is make a digital recording in the computer's memory of the sound you want. Then you isolate one cycle in this recording and load it into the DVCO. Obviously many natural sounds change their harmonic content through the duration of the sound or in relation to the pitch. The DVCO output waveform will not change in this manner (unless of course you update it in real time) but with careful selection

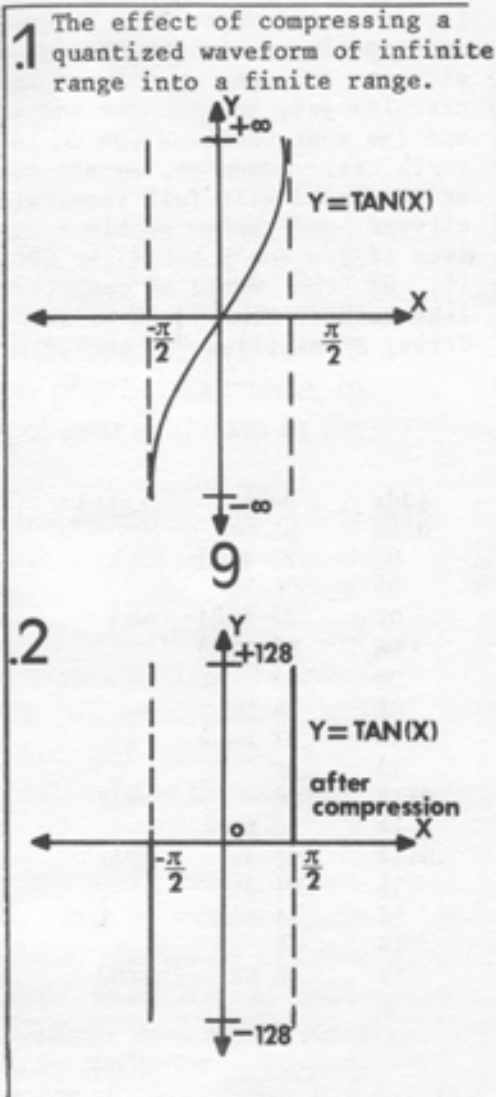

of the waveform written to the DVCO and some additional filtering and envelope shaping, realistic sounding synthesis can start to happen with relative ease.

Another area for exploration might be updating the data in the DVCO every note (not cycle) to simulate a limited form of polyphony. An example might be the guitar patch. If you get a guitar waveform (for a single string) into the DVCO using the process above, you could combine copies of the waveform (each copy with a different period) in memory; the result from the DVCO could sound like more than one string at a time (i.e. a chord). The computer could read a set of switches to determine which periods to use for each note - that way the user could control which chords were produced in real time. The problem with this process is that it would lack some reality. The differing waveform lengths would not all fit evenly into the 128 word length of the DVCO memory. I have not tried this idea, but some experimenting may reduce the 'splicing' problem to a usable point. (Maybe tailoring the ends of the waves that don't quite fit?)

Obviously I have only scratched the surface of the uses and expansions that you could come up with. For this reason, it is my sincere hope that many of you do build the circuit and experiment with it. I realize that it is a rather complex circuit and many of you may not feel comfortable with digital circuits yet, but I think the experience you would get from it and the contributions you could make to technology are well worth it. Remember, we all must keep technology moving ahead or the world will fall into atrophy. If you do build the circuit and have problems or ideas, please drop me a line. Even if you don't build the DVCO but have some thoughts about it, or the world of computers and audio in general, I would like to hear from you. Write: Tony Lewis, 12224 Daugherty Drive, Zionsville, IN 46077.

DVCO TEST ROUTINE

Assembled for MC6800 CPU

Addr	Data	Label	Mnemonic	Comments
0100	86 00		LDAA #00	
02	B7 8001		STAA 8001	Take control of DVCO
05	C6 80		LDAB #080	Set up Length Counter
07	B7 8001	WRT	STAA 8001	Write ACCA to DVCO memory
0A	B7 8003		STAA 8003	Inc DVCO Address Counter
0D	SA		DECB	Dec Length Counter
0E	26 04		BNE NVAL	If Length counter ≠ 0 go to NVAL
0110	B7 8000		STAA 8000	Set Free Run Mode
13	3F		SWI	End program
0114	4C	NVAL	INCA	Inc data in ACC A
15	20 F0		BRA WRT	Goto WRT (To generate ramp)
0114	86 FF	NVAL	LDAA #0FF	Load ACCA w/hex FF
16	C1 40		CMPB #040	Is Length Counter 40
18	2A 01		BPL RTN	If yes go to RTN
1A	4F		CLRA	If no clear ACCA (square wave)
1B	20 EB	RTN	BRA WRT	Go to WRT

Listing 1

TRIGONOMETRIC FUNCTION GENERATOR FOR THE DVCO

```

10 DIM A(128)           set up data matrix
20 M1=1:M2=9.99E99:L=1  initialize variables
30 FOR X=0 TO 6.2834 STEP 0.049095 generate 128 X values (one at a time)
40 Y= users equation in terms of X calculate Y based on present X
50 PRINT X,Y           show each ordered pair
60 IF Y M1 THEN M1=Y
70 IF Y M2 THEN M2=Y   look for max. and min. Y values
80 A(L)=Y:L=L+1:NEXT X save Y values in matrix and loop back
90 F=C-M2.K=225/(M1-M2) set scaling constants using max and min Y
100 FOR X=1 TO 128:A(X)=(A(X)+F)*K do scaling, return scaled data to matrix
110 PRINT:PRINT:PRINT A(X);"";:NEXT X show scaled values and loop back
120 PRINT "SCALING COMPLETE-START DATA TRANSMISSION"
130 POKE(32789,0)      take control of DVCO
140 FOR X=1 TO 128:POKE(32789,A(X)) write data to DVCO
150 POKE (32791,0):NEXT X increment DVCO Addr counter and loop back
160 POKE (32788,0)    set free run mode
170 PRINT "DATA TRANSMISSION COMPLETE"
180 END

```

NOTE: Addresses used in POKE statements are in decimal instead of hex. The addresses listed are for the DVCO in my system; your addresses may be different.

Listing 2

PARTS LIST FOR THE DVCO

DIGITAL SECTION

IC1, IC2	74C93 CMOS binary counter
IC3	MCM6810AP MOS static ram
IC4, IC5	74LS367 TTL tristate buffer
IC6	74LS139 TTL 2/4 line decoder
IC7	CD4001 CMOS quad NOR gate
IC8, IC9	CD4050 CMOS hex buffer
IC10	CD4016 CMOS bilateral switch
IC11	LM301 op amp (LM318)
R1, R2, R5	4.7K
R3, R6	10K
R4	1K
R7	3K
R10-R17, R25	3K 1%
R8	680 ohms
R9	1.5K
R18-R24	1.5K 1%
D1, D2	1N914 or 1N4148

Note: R10-R25 can be 5% carbon units, however this will result in slight distortion of the output waveform due to D/A error. If 1% units are used, this problem will be minimized.

FREQUENCY MULTIPLIER

IC401	CD4049 CMOS hex inverter
IC402	CD4030 CMOS quad exclusive OR
R401, R402	20K trim pot
C401, C402	560pf mylar cap

HFVCO SECTION

IC101	LM301 op amp (LM308)
IC102	NE566 VCO
R101-R103	270K
R104	47K
R105	4.7K
R106	5K linear pot
R107	10K
R108	2 Meg
R109	5K 10 turn trim pot
R110	470K
R111	5K 10 turn trim pot
C101	30pf disc
C102	0.1uf disc
C103	370pf polystyrene*
D101, D102	1N914 or 1N4148

OUTPUT FILTER

IC201	LM301 op amp (LM318)
R201, R202	10K
R203	100K dual linear pot
R204	10K linear pot
R205	39K
R206	22K
C101, C102	250pf polystyrene*
C103	5pf disc
C204	3.3uf electrolytic

Note: All parts marked with an * are mentioned in the text as ones for which the user may want to alter values.

All resistors are 5% carbon rated at 1/4 watt.

All polystyrene caps need to be rated at 5% or better for good performance.

Parts in parentheses may be substituted for the primary parts. The substitutes significantly improve circuit performance.

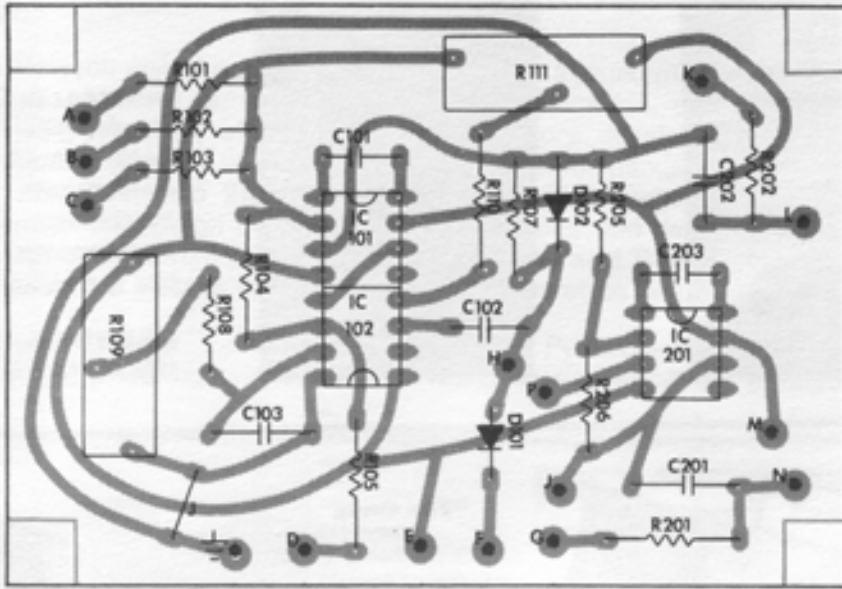

Component Side

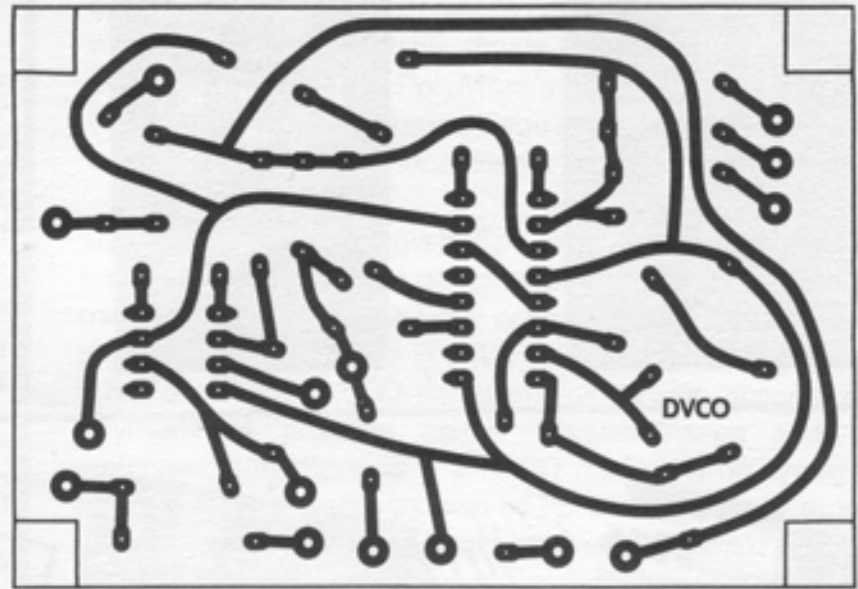

Foil Side

Wiring Connection Chart

- | | |
|--------------------|------------------|
| A, B, C: CV Inputs | J: Filter Output |
| D: Range Pot | K: 1st 1/2 R203 |
| E: V- | L: 2nd 1/2 R203 |
| F: +5 volts | M: V+ |
| G: Filter Input | N: 1st 1/2 R203 |
| H: Clock Out | P: 2nd 1/2 R203 |

Remember to clean flux from PC board after soldering to avoid drift problems.

PC Board Layout for Analog Sections of the DVCO

HFVCO & Output Filter

Was This Feature Project Too Long?

Do You Want Shorter Projects?

Let Us Know!

NEW FROM POLYMART!

Solid State Micro Technology
for Music



1979 DATA BOOK 1979

NEW FROM SSM!

One of the leaders in music ICs, SSM has published their spec sheets, design examples, and applications notes for their growing line of music ICs. Includes info on the new 2044 4 pole filter and 2055 envelope generator, plus extended filter applications. Regardless of which of the four brands of music ICs you work with, this book will be a valuable addition to your educational and applications library. Order # SSM \$5.50

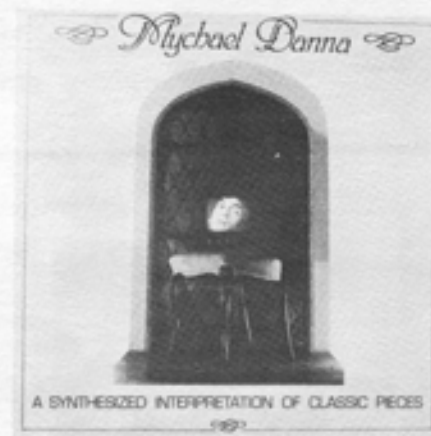

NEW FROM DANNA!

The second solo effort from Canadian synthesist Mychael Danna concentrates his superb keyboard, arrangement, and synthesis skills on nine classics from Handel, Rachmaninoff, Chopin, Pachelbel, Bach and Gluck. These are very sensitive 'chamber' synthesis arrangements with primarily imitative voicings, but a few 'electronic' voices and effects throughout. Order # DANNA \$6.95

To order, use the convenient form on the Polymart page, or enclose full payment plus \$1.00 for the first item and \$.50 for each additional item (\$1.00 per item on shipments outside continental US) to help defray shipping costs. Cashiers check or money order preferred; MasterCard, Visa, and personal checks also accepted.

POLYMART PO Box 20305, Oklahoma City, OK 73156

POLY MART

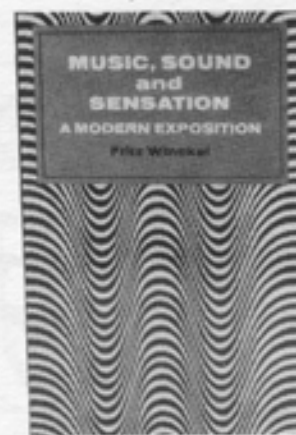
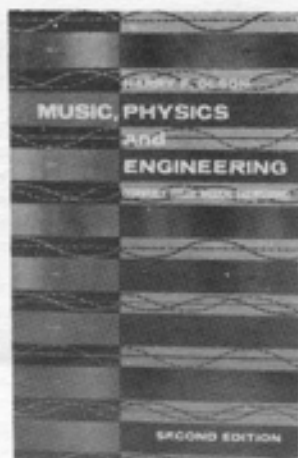
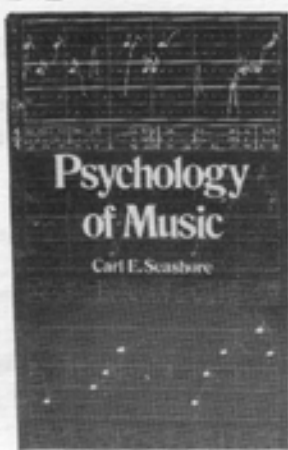

The physical and Helmholtz's **Sensations of Tone** provides a physiological acoustic test, provides a synthesizer, is a synthesizer (plus like the Helmholtz)

#SENS On The Sensations of Tone
#MPE Music, Physics and Engineering

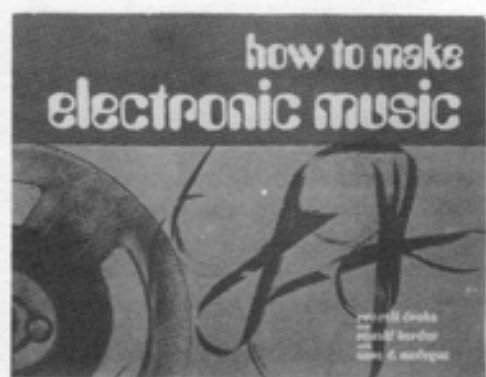
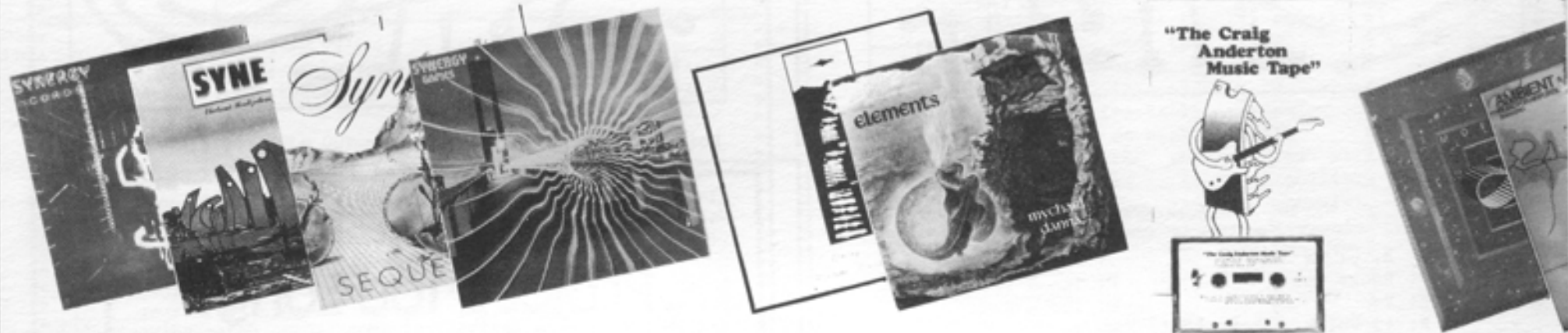

Synthesists must have these books. A great volume and Modugno is a synthesizer tape technique, computer control, building, outfitting, computer control.

Home Recording for maximum results.

#HMEM How to Make Electronic Music
#BYTE Byte Book of Computer Music

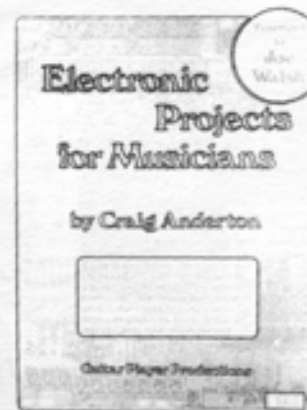
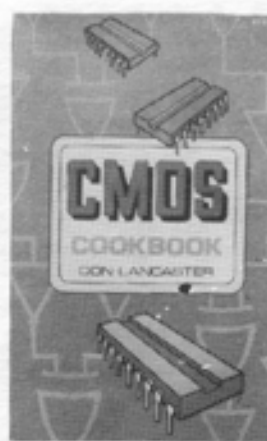
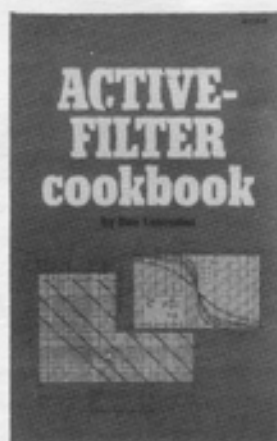
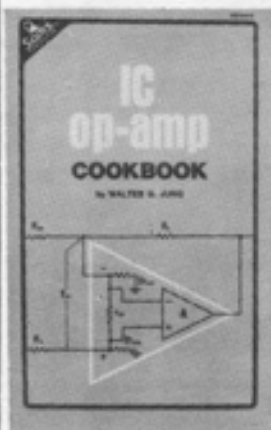

Electronic cookbook theory, definitions, and you can easily replace a reference. Walt Jung required reading for applications. Lancaster's octave generators, electronic construction, recording of the effect.

#OACB Op-Amp Cookbook
#AFCB Active Filter Cookbook
#AUOA Audio Op-Amp Applications

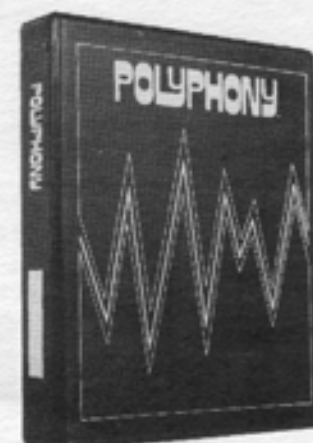
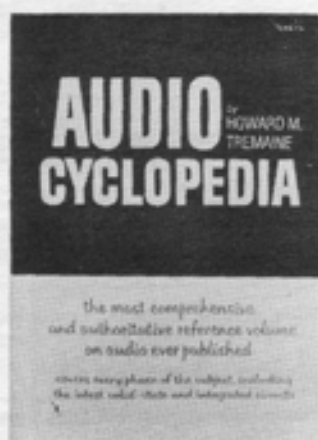

Often used reference. **The Source** is over 1000 type. **Audio CycloPedia** to answer any question. publication without **Synthesizers** devoted to Paia, Oberheim, EM, experimenter.

#SOURCE The Source
#CYCLO Audio CycloPedia
#BIND Polyphony
#EMS Electronic Music Synthesizers

Back Issues

The wide variety of practical applications and construction projects in past issues make a binder full of Polyphonys a frequently used reference to keep near your synthesizer, home studio, or workbench. Most back issues are still available for \$2 each ppd. Check the issues desired on this coupon and add the total to your PolyMart order (other side), or order by volume and issue numbers (0304, 0402, etc) on the PolyMart form.

#0101: 1975: SOLD OUT

#0201: 1/76: (LIMITED SUPPLY) glide footswitch, low-cost preamp, sequencer game, LFO trigger generator project, patches.

#0202: 2/76: SOLD OUT

#0203: 3/76: SOLD OUT

#0204: 4/76: music notation- timing, external inputs for Gnome, Programmable Drums, Equally Tempered D/A, low cost AR project, digitally encoding keyboards, patches, Vol. 1 & 2 index.

#0301: July 77: frequency divider project, random tone generator project, normalizing synthesizer controls, eliminating patch cords, computer control of analog modules, Chord Egg modification, adding pitch bending, patches.

#0302: November 77: The Sensuous Envelope Follower, digital gates, LED wall art, build a bionic sax, data to music peripheral project, Apple II as a music controller, using the NE566 as a VCO, patches.

#0303: February 78: computer controlled Gnome, using joysticks, build a bionic trumpet, octave controllers for bionic sax and trumpet, ultra-VCO modifications, voltage control the Mu-Tron Bi-Phase, oral joystick, patches.

#0304: April/May 78: Minimoog modifications, non-keyboard module use, phasing and flanging (theory and circuits), memory expansion for programmable drums, digitally addressed transposer project, polyphonic software (with software transient generators), patches, Vol. 3 index.

#0401: July/August 78: analog delay lines (theory and projects), composing for electronic music, note to frequency (and vice versa) conversions, build a trigger delay, software for computer composition, low cost VCO circuit, patches.

#0402: September/October 78: electronic music notation, notes on the recording of "Cords" by Larry Fast, sequencer software- part one, rhythmic control of analog sequencers, touch switch projects, modular vocoder techniques, PET as a music controller, patches.

#0403: (LIMITED SUPPLY) November/December 78: multi-purpose keyboard software, Sohler keyboard and notation system, voice, frequency to voltage converter project, proposals for tape exchange, VCA project, sequencer software- part two, frequency balancing in recording, Barton and Priscilla McLean.

#0404: January-March 79: add-ons for vocal F to V converter, shorthand patch notation, more on note to frequency conversions, graphic monitor project, George Russell, super VCA circuit, echo software, Vol. 4 index.

#0501 (LIMITED SUPPLY) May/June 79: using click tracks, PET music software, clockable sample/hold and noise source project, voice processing patches, VCF circuits, profile of John Cage, linear DAC.

#0502 July/August 79: hex VCA/mixer project, electronic music schools and studios, modify the Oberheim Expander Module, profile of Ernest Garthwaite, budget microphones, digitizer projects and software, bar graph ICs.

#0503 September/October 79: SOLD OUT

#0504 November/December 79: SOLD OUT

#0505 January/February 80: Joseph Byrd, Mort Garson, Larry Fast on 'Games', composing for 'live plus tape', using the CA3280, recording vocals, ADSR circuits.

#0506 March/April 80: Computers in Music: real time audio processing- hardware, Powell sequencer system, Max Mathews, advanced STG software, PortaStudio, phase modulation, Volume 5 index.

#0601 May/June 80: Gary Numan, harmonizing devices, real time audio processing- software, digital delay project, writing documentation, Richard Hayman.

DYNAMIC PHRASING

Continued from Page 7

on to other tracks and will not be removeable further on down the line.

RULE #7: RECORD GUIDE TRACKS, REFERENCE TRACKS, AND SYNC TRACKS AT THE LOWEST POSSIBLE LEVELS. In most of my recording, I have an electronic sync track (consisting of low frequency pulses) recorded in one tape track, along with guide vocal tracks, reference premix tracks, and the like. These should be recorded at the lowest possible level in order to avoid leakage. Sync tracks in particular can leak if recorded at high levels.

Hopefully, the above rules will help you set levels in the best possible way with varying program material, equipment, and musical requirements. However, try to remember that you never know when rules are made to be broken...maybe by deliberately abusing some of the suggestions given above, you'll come up with some new type of sound or effect.

The most important point is that level-setting requires as much care as you would devote to tuning your instruments, maintaining your equipment, or writing a song. Don't forget that the way in which your recorder responds to signals will ultimately determine how your tape will sound; the record level control is the gateway that allows your real world signals to enter the peculiar, and somewhat particular, environment of the tape recorder. Control that gate wisely, study its characteristics, and your music will benefit as a result.4

Copyright 1980 Craig Anderton

Send Us Your Ideas!

for projects, interviews, columns, reviews, or ...?... Polyphony can provide all the material you need; give us the raw ideas - we'll find people with info! Our increasing scope and space for coverage make Polyphony your #1 source of info on experimental music technique.

The people who publish **The Audio Amateur** welcome your subscription to our NEW publication. . .

SPEAKER BUILDER

IF ONE HALF THE CASH you spend on your audio system should be invested in your speaker, why not build it yourself? Nearly 100,000 Americans will do so this year—why not you too? Your dream speaker just may be possible *only* by doing it yourself. There's a lot of help around already and now this new quarterly publication from the publishers of *The Audio Amateur* promises an assortment of articles that are comprehensive and a mix of both simple and advanced projects about all types of speakers.

- ★ Bass Reflex
- ★ Horns
- ★ Electrostatics
- ★ Transmission Lines
- ★ Infinite Baffle
- ★ Specials: Ribbon, Air motion transformers and many others.
- ★ All the basic data on passive and electronic crossovers.

There will be kit reports on building the many speakers and enclosures now available in kit form and a roundup of suppliers of drivers, parts, and kits.

We have articles in hand that range from the ultimate (650 Lbs each) to very simple extension speakers. From time delayed multi-satellites to horn loaded subwoofers. There will be modifications of many stock designs as well as resurrections of great classic designs out of the past.

We'll be doing basic articles on the design theory behind each of the great classical speaker formats. And you'll find lots of reference data on design formulas, crossover coil winding guides and much more. **Speaker Builders** will have a lot to say to each other in the column on tips, photos of systems, in the letters exchange as well as swaps of gear and data in the columns of free classified ads.

Standard format 8½ x 11" on good book paper, with clear diagrams and photos and all the data you need to build each project successfully and without undue hassle, **Speaker Builder** will be reader-centered and reader supported and NOT a thinly disguised marketing medium catering to advertisers. Ad ratios will never exceed 40% (*the national average is over 60%*). Guarantee: if you are not satisfied with **Speaker Builder** the publisher will refund the unused portion of your subscription.

The price is \$10 per year, for the four quarterly issues, or just \$18 for two years. Use your charge card to execute your order (signature with order blank below, please) or call our charge card order desk for **Speaker Builder** at (603) 924-6526 from 8am to 4pm on weekdays and leave your order. Tell your friends about **Speaker Builder** or include their names with your order and we will send them full information about the publication and how to subscribe.

ORDER BLANK

SPEAKER BUILDER Magazine

P.O. Box 494, Peterborough NH 03458 USA

M50

Enter my charter subscription to **SPEAKER BUILDER** for one year at **\$10.00.**

Make that a two year charter subscription at **\$18.00.**

Check enclosed Charge to my MasterCharge Visa charge card.

Expire___/___

Name _____

Street & No. _____

Town _____ State _____ ZIP _____

I understand that the unexpired portion of my subscription will be refunded after my first issue if the magazine is unsatisfactory for any reason. Make checks and money orders payable to Speaker Builder. Rates above are for USA only. Outside USA add \$1.50 per year for postage. Non U.S. checks must be drawn in U.S. currency only.

INDUSTRY REPORT

'Tell Them You Saw It In Polyphony'

POLYPHONY PUB.CO.

Volume 6-Issue 2



Synclavier II

For years now, the development of a fully programmable digital synthesizer has been an increasingly important goal of many synthesizer manufacturers. No one has been able to successfully design a system that has the sounds and flexibility musicians demand, and that is easy to understand and operate. Recent developments in digital systems have proven to be too complex for musicians to use, partly because these systems required the use of a computer terminal for programming sounds and partly because the systems themselves were explained in a "digital talk" largely unintelligible to the music community. In addition, these systems were quite unwieldy to handle and very, very expensive to buy.

New England Digital has been working for five years to design a system that could be easily understood and operated by musicians all around the world. The first thing they did was to completely eliminate the need for a computer terminal of any kind to program sounds. No computer terminal is needed to operate any portion of the Synclavier II. It's all done by select buttons. A terminal is available for people interested in that aspect of programming computer music. All select buttons on the front panel are labeled according to their musical function, not according to their digital function. Most of the select buttons are labeled in terms that the musician will be familiar with from using analog synthesizers. Second, they designed a truly portable system without sacrificing either quality of sound or programming capability. They designed the fastest and most powerful synthesizer computer available today, and made it so compact that it fits into a travel case less than 19 inches square. The computer is programmed in a high level language which is a slightly modified version of XPL. Lastly, they designed a completely portable keyboard unit. From 8 to 128 fully programmable voices, a five octave keyboard, and a complete 16 track digital memory recorder are all housed in a cabinet about the size of a Minimoog (Reg. TM). No analog system in the world offers $\frac{1}{4}$ of this capability in a system four times as big.

Synclavier II is available with 8, 16, 24, or 32 voices. On special order, the same size keyboard can be made to control up to 128 voices! And the control you have over these voices goes beyond anything you've ever experienced. A unique new partial timbre method of synthesis allows you to create sounds with unheard of accuracy. In fact, many of Synclavier II's sounds are virtually undetectable from real instruments. Everything from huge church bells to violin harmonics can be created with life-like clarity. But Synclavier is by no means limited to real instruments. It goes far beyond the familiar to offer you an endless universe of new sound combinations never before possible on any synthesizer.

Synclavier offers the most extensive array of live performance controllers ever assembled in one system: two foot pedals, five foot switches, a ribbon controller, and an optional velocity sensing keyboard! The unit is also equipped with the largest and most versatile 16 track digital memory recorder available today. It's so advanced that one third of its standard features cannot be found on any other system. And, although the recorder uses memory instead of tape, it

operates much like a 16 track tape recorder, so it's easy to understand and easy to operate. There's no limit to the number of different sounds and finished 16 track recordings that can be stored on Synclavier's diskettes. When you recall a sound from a diskette, it's always the exact sound you stored. Nothing ever has to be reset. Even after you've stored a sound, you can recall it, modify it, and restore it without erasing the original sound from the diskette. Over 64 sounds have been carefully programmed for you, including over three dozen real instruments and over two dozen sounds unique to the Synclavier II. Any of these sounds can be recalled for immediate use with just the push of a button. Once recalled, any sound can be easily modified into an endless variety of new sounds, with the capability to additionally store your modified versions.

Synclavier II is not only easy to use, it's easy to set up. The entire system sets up in the studio or on stage in minutes. Heavy duty cables connect the computer to the keyboard with easily attached multi-pin connectors. A special performance table assembles quickly, holding the keyboard at the height of a Fender Rhodes. A diskette drive box conveniently attaches under the front edge of the table for quick loading of diskettes. And once you've set up the system, you can forget about the computer. Synclavier II is designed so no access to the computer is required during live performance. All playing and programming functions are completely controlled from the keyboard unit. Everything you need to operate Synclavier II is located within easy reach.

Never before has any system made so much so easily accessible. Never before has any system been capable of creating such incredibly authentic sounds. Never before has any system offered a full 16 tracks of recording capability plus unlimited sound storage, and placed it all at your fingertips. Never before have you been able to get more information (a beautiful 8 page brochure will tell the whole story) on the Synclavier II by contacting: New England Digital, Main Street, Norwich, VT 05055, (802) 649-5183.



E-MU Storage

E-mu Systems, Inc. has announced the availability of the Model 4070 floppy disk memory unit. Designed to be used with the E-mu 4060 microprocessor-based 16 channel polyphonic keyboard/sequencer, the 4070 allows fast, convenient storage and recall of polyphonic sequences and special function software.

The unit consists of an 8 inch floppy disk drive with cabinet, power supply, and terminal interface for use with forthcoming software. Each floppy disk will store six full sequencer memories for a total capacity of 36,000 notes.

The price of the 4070 is \$3000 which includes the disk

drive, interface, cables, a replacement ROM with UPl.1.DISK, and 10 floppy disks. Required for use is a 4060 keyboard with at least one 4065 sequencer memory (three are preferred). For more information contact E-mu Systems, Inc., 417 Broadway, Santa Cruz, CA 95060, (408) 429-9147.



New Wavemakers

WAVEMAKERS announces the WAVEMAKER 6 synthesizers and the WAVEMAKER 600 series synthesizer sub-systems and accessories. The Wavemaker 6 is available in 2, 4, 6 and 8 voice configurations and is made up of the following 600 series sub-systems:

The 652 Dual Voice Sub-System supplies all of the functions needed to create and shape a sound including 2 VCOs each with 2 voltage controlled waveform mixes providing unusually strong timbral variations, 2 continuously variable multi-mode voltage controlled filter-amps, 2 AR contour generators with variable sustain and self-triggering modes, and an FM generator of exceptionally wide range (.05 - 2kHz, more with control), multi-waveform output and voltage controlled level.

The 654 Control Array includes an 8 step analog sequencer, sample and hold with percentage variable trigger delay, a four quadrant joy stick controller which attenuates input control voltages as well as offsets four DC control voltages, 2 delayed ADSR envelope generators with internal or direct control modes, a lag processor, and finally, four Control Buss groupings for routing the systems controls.

Keyboards in this series begin with the 653 Dual Keyboard Controller with 2 independent voice controllers, each with independent portamento, pressure sensitive pitch bend and variable scaling (1V / 8va by switch). 4, 6 and 8 voice keyboards are also available.

The 658 Digital Sequencer, like the other subsystems in the 600 series, is available as an accessory or as part of a Wavemaker 6 synthesizer. The 658 offers unprecedented programmed control to the synthesizer. It is the first digital sequencer available with a standard non-volatile memory. It is fully editable, has numerous external command and control functions and will memorize up to 32 different sequences including rhythmic variations.

Complete systems are available from \$1750, and are available from local consultants. For more information, contact: Wavemakers, Box 27, Edmonds, WA 98020, (206) 542-8041.



Stereo Image

Sound Concepts introduces the IR2100 Image Restoration Control. The IR2100 removes the sonic barrier of speaker position to produce the full breadth and width of the recorded soundfield over conventional stereo systems. Drawing upon research originally conducted for binaural recording and reproduction, the device uses analog delay techniques to correct mistimed signal arrival at the listeners ears caused by "narrower than real world" placement of speaker systems. A calibration control adjusts operation to fit speaker angles of from 20 to 100 degrees. Image Control varies the level of compensation to optimize imaging for variations in recording techniques or emphasize perimeter sounds. A master volume control is also included in the hand-held unit which comes with 15 feet of cable so it may be adjusted from the listening position.

The suggested list price for the 7" X 3" X 1.5" unit is \$229. An indepth explanation of theory of operation and set-up is available in the bulletin "Background on the IR2100 Image Restoration Control" as well as the owners manual. For this information, contact: Sound Concepts, 27 Newell Road, Brookline, MA 02146, (617) 566-0110.

High Tech Drum

Star Instruments (Box 145, Stafford Springs, CT 06076, (203) 684-4258) has introduced four new special purpose drum synthesizers, each being optimized for generation of specific effects: the Synare Bass, Synare Hi Tom, Synare Lo Tom, and the Synare Tympani.

The Synare Bass is capable of producing short, medium, and long bass drum sounds that are tunable with a single

control. Also featured are a unique Double, Triple and Repeat function for rolling effects as well as Decay, Sensitivity, and Volume controls. The unit is AC powered and self contained with an 8 inch head. Suggested retail is \$299.

The Synare Lo Tom offers seven controls (Tune, Range, Speed, Direction, Output Decay, Sensitivity, and Volume) to duplicate the effect of 14" to 18" acoustic floor toms. The Lo Tom features a new run capability which is a continuous stepping of pitch with each subsequent strike of the head. Run Range, Speed, and Direction are easily chosen from the front panel. Runs that used to require 10 acoustic drum can now be accomplished with one electronic drum. The Lo Tom features an 8 inch head, AC power, and optional foot switch control at a suggested retail of \$299.

The Synare Hi Tom is identical to the Lo Tom with the exception that it duplicates 5.5" to 16" acoustic toms, and also carries a list price of \$299.

The Synare Tympani is the first such instrument, affording all drummers the luxury of owning tympani which are easy to handle as well as inexpensive. The Tympani is easily tuned with either the front panel control, or with an optional foot pedal. Unlike conventional tympani, the Synare stays in tune despite temperature and humidity changes. Special features include upsweep, downsweep, sensitivity control and dynamic head response as well as standard decay and volume controls. With packaging similar to the other new drums, the Synare Tympani lists for \$325.



New RMI Digital

Rocky Mount Instruments, Macungie, PA 18062, announces the DK-20, a new digital combo keyboard designed to meet the varying needs of the club musician. The DK-20 produces a wide variety of sounds, including guitar, piano, flute and clavinet, available with custom factory voicing and presets. Musicians can create their own sounds with Digital Envelope and Timbre controls, or use any of twelve available presets. Additionally, vibrato can be added to any sound at the touch of a button.

Digital Tone Generation, a step beyond oscillator and filter effects, produces the DK-20's fresh, clean sounds. The instrument features Polyphonic Timbre Modulation; each note played independently exhibits complex timbre changes during its envelope. The "Transient" button on the DK-20 creates a brilliant biting edge during initial timbre stages. Each note stands out clearly, even in heavy chords and the most competitive band situations.

The DK-20 is as easy to play as an electronic piano, and pianists will appreciate the sustain pedal as well as sostenuto. Another big feature is the built-in mixer for custom blending of sounds and stereo output mixing. Separate Bass and Treble outputs are located on the rear jack panel. Legs, pedals and case are included.

Harmonizer Options

At the recent AES Convention in Los Angeles, Eventide Clockworks previewed two forthcoming options for their model H949 Harmonizer. These new options increase the versatility of the H949 in two important areas -- getting rid of "glitches", and computer remote control. The H949 is Eventide's "top of the line" unit, which operates as a pitch changer, digital delay line, flanger, ADT (automatic double tracking) unit with true randomized delay, and all-round special effects device.

The first option is a signal processor/ analyzer board, which will eliminate almost completely the "glitching" characteristic common to all pitch change devices which operate by adding or eliminating signal segments. This computerized addition determines the optimum splicing point, thus reducing the potential "glitch" to inaudibility in most cases. Eventide stresses that this board does not necessarily replace its current splicing methods, which also reduce or eliminate "glitches" in other manners. Booth personnel reminded all listeners that any pitch change unit will, for theoretical reasons, be less than perfect, and the choice provided by the H949 will allow optimization for all types of program material.

The second option demonstrated is the Computer Remote Control board. This enables almost all functions of the unit (including pitch change) to be controlled by an external computer. The unit uses the IEEE-488 standard, which permits multiple units to be controlled individually on a single bus, thus reducing the cost and the complexity of interconnection. This is the second IEEE-488 product introduced by Eventide, the 1745M digital delay line remote control having preceded it by two years. The unit is completely compatible with the IEEE standard, and can be controlled by low-cost home computers (such as the Commodore PET and the Hewlett-Packard module 85), as well as several automated consoles and industrial computers.

Both the new options for the H949 are designed to fit inside the unit, and will be available around August 1, at which time firm pricing and delivery will be quoted. At that time, the options will be available both installed in new units, and to all H949 owners for field or factory installation. For more information, contact: Eventide Clockworks, 265 W. 54th St., NY, NY 10019, (212) 581-9290.

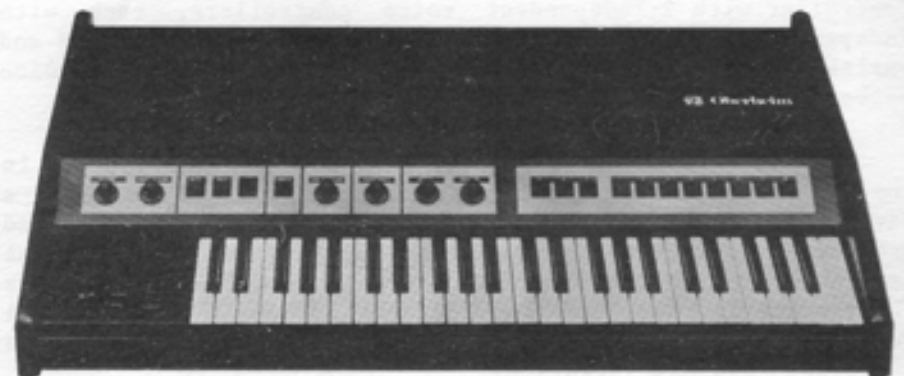

Low Cost Poly

Oberheim Electronics offers two new polyphonic synthesizers, the OB-SX(6) and OB-SX(4). The OB-SX(6) is a six voice polyphonic synthesizer utilizing the same proven circuitry as used in the OB-X, hence the same Oberheim "fat" sound. The OB-SX(4) is identical except for having four voices instead of six. The OB-SX(4) can be upgraded to a six voice at any time by the user simply by adding two additional voice cards. The OB-SX series differs from the OB-X series in that it's much smaller and easier to use since user programmability is not necessary. The OB-SX is a true polyphonic synthesizer for the keyboard player, whereas the OB-X is primarily used by the synthesist.

Features include: four voice or six voice option; 24/48 program option; four octave keyboard; operates on line voltages from 90-130 volts or 180-260 volts; pitch bend and modulation levers; auto tune; hold/chord feature; edit mode, unison, portamento, LFO rate, oscillator 2 detune, filter frequency, attack, decay and release; and transpose.

Rear panel interfaces: filter pedal; sustain foot switch; modulation pedal; CV in/out; gate in/out; group A/B program switch; and Oberheim computer interface.

The OB-SX(6) lists for \$3495 and the OB-SX(4) lists for \$2995. For additional information, contact: Oberheim Electronics, 1455 19th Street, Santa Monica, California 90404.



Analog Delays

The Korg SD200 features a delay range of 30 - 400 milliseconds to generate effects such as doubling, hard reverb, and long delay echoes. Tone control is provided for the delayed signal only. Features include a 2 input mixer with attenuation, mixed and delayed outputs with attenuator, footswitch jack, and a 9 LED input level meter for overload and headroom indication.

The SD400 features an analog delay system with a range of 25 - 400 milliseconds, plus a studio quality Automatic Double Tracking Effect. The effect select knob allows fast selection of direct sound, short delay (25 - 100 ms.), long delay (100 - 400 ms.), Swell 1 and 2 ("staggered" effects, using short and long delays), and Automatic Double Tracking. The built in compander noise reduction circuit provides virtually noise-free signal.

For more information, contact: Unicord, 89 Frost Street, Westbury, NY 11590, (516) 333-9100.

Guitar Effects

Zeta-Systems brings you five of the most used guitar effects combined in one noise-free, on-board, active package. Measuring 1½" X 2", the Little FEANC (pronounced fink: fuzztone, equalizer, amplifier, noisegate, compressor) will fit in any guitar replacing the standard controls. Using FET technology, the FEANC gives you an order of magnitude more compression (infinitely variable) with significantly less pop and noise. And if that isn't enough, a switchable noisegate silences the output when no signal is present. This integrated unit takes the guitar signal or an instantly available fuzztone and filters it with a 2-band equalizer. The signal is present through a master volume control and exits the guitar as a high-level, low-impedance source. The integration of

these five effects in one compatible system gives the guitarist quiet, versatile control at his finger tips allowing freedom of movement on stage.

The Little FEANC retails for \$149.95. For more information, contact: Zeta-Systems, 1122 University Ave., Berkeley, CA. 94702, (415) 848-7728.

Device Has Moved

DEVICE, the publication for electronic musicians (edited by Craig Anderton), has moved its headquarters back to northern California. DEVICE, having just completed its first volume, is establishing a network of musicians interested and involved in all aspects of musical electronics. The first volume has yielded designs for flangers, power amps, and indepth effects opinion poll (available in reprint form), and the guidelines for a proposed effects standard.

The DEVICE subscription rate in the U.S. remains \$15 per 12 issues and the publication is still subscriber-supported. Inquiries should be sent to the new address: 1085 Broadmoor Drive, Napa, CA. 94558.

TRS Music

Software Affair, Ltd. has introduced ORCHESTRA-80, a TRS-80 music synthesis system written by Jon Bokelman, which consists of software and hardware to be used on a 16K Level II TRS-80.

The software is a five part machine language program: a digital synthesizer, which produces four simultaneous voices in a six octave range; a music language compiler, which allows users to enter their favorite music in any key or time signature; a full function text editor with blinking cursor; and a file manager, which provides for the orderly storing and retrieval of named program files on tape or disk.

The hardware is a single 1.5" X 2" PC board, completely assembled and tested, which plugs into the expansion connector of the TRS-80 keyboard or the screen printer connector on the expansion interface. Tape and disk version are supplied on cassette, with sample music programs. A detailed and complete instruction manual is also included. For additional information, write to: Software Affair, Ltd., 473 Sapena Court, Suite 1, Santa Clara, CA 95051. Those interested in listening to ORCHESTRA-80 can dial the demonstration line at (408) 727-8194.

Recording Supplies

A complete line of audio and video reels and boxes highlights the new professional recording and duplicating supplies catalog just published by Polyline Corp.

Featured are ¼" tape reels with 3", 4", 5", 7", and 10½" flanges--some available with large or small hubs; ½" tape reels with 5 1/8" and 7 1/8" flanges; 1" tape reels with 6½" and 8" flanges; and 2" tape reels with 5½", 6½" and 8" flanges.

Also available in the new catalog are reel-to-reel tape, an expanded line of audio cassettes, and a variety of professional recording and duplicating accessories.

Polyline Corp., a manufacturer of reels and boxes for the recording industry since 1950, offers its catalog free of charge on request. Write or phone: Polyline Corp., 1233 Rand Road, Des Plaines, IL 60016, (312) 298-5300.4

Tell Them You Saw It In Polyphony

and now for something completely different...



Dream Module Contest

RESULTS!

Working with applying the front edge of technology to the real world is a less than ideal situation. More often than not, the engineering personnel of the leading manufacturers are the individuals who determine the commercial availability of the sole tools of a large number of creative and artistic people. In many cases this can cause a market saturation of similarly designed instruments which are based heavily on new technologies becoming available at the component level, but with little attention paid to the state of the musical art, and the problems and possible solutions for the creative user. The Polyphony/ Blacet Dream Module Contest was created to vent the frustrations and needs of the user market in an attempt to provide the manufacturing engineers with "personal" input not readily available through most channels. Surprisingly, the problem seems two-fold. There were a number of entries which were near perfect product descriptions for a number of new tools which have appeared on the market over the last two years. Perhaps this is due to sparse marketing by the manufacturers; perhaps it is due to inadequate media absorption by the consumers. In any case, it is an example of the lack of communications within the high technology music industry. And that is what needs to be solved through Polyphony and similar magazines.

The winning entry based on creativity, applicability, and presentation stood out strongly amidst the entries. The description of the CYBORTAR by Kurt Schultz is reproduced in full on the facing page so you can benefit from Kurt's many drawings. Although there have been a number of "guitar" type controllers introduced recently, most are based on either wearing a keyboard around your neck, or pitch follower guitar controllers. Kurt's concept embodies a wide range of controller devices, including a new pitch control system, in a biologically convenient package.

The four runners-up covered a wide range of technologies as applied to a number of creative problems. Walt Simmons presented an idea for a WAVEFORM INJECTOR. "It's pretty easy to patch up a synthesizer to sound about like any natural instrument. However, for a synthesizer to sound exactly like a given instrument is another matter. It takes some pretty crafty patching to sound close to a trombone or a sax as it is. Even if you spend hours working on such a patch, chances are you will never be quite satisfied with your "perfect" sound. The fact is, today's synthesizers can imitate a natural instrument only to a certain degree. No synthesizer can sound exactly like any given acoustic instrument.

Just what sort of module can allow any synthesizer to sound like a flute or a bassoon? The module is called the Waveform Injector. It does exactly what the name implies; it injects or superimposes a series of different waveforms onto a main carrier waveform. By different ways of manipulating the Waveform Injector, the synthesist can make the ordinary triangle waveform from his oscillator turn into a waveform of

practically any given instrument. A synthesizer that puts out a saxophone waveform has got to sound like a saxophone; that makes sense!

First of all, look at the ordinary triangle waveform in figure 1. It's the typical unprocessed triangle waveform from an average oscillator. Now look at the waveform pictured in figure 2. It happens to be the same innocent triangle waveform after being processed by the Waveform Injector. Look at the waveform of a violin in figure 3. It looks like a carbon copy of figure 2. Actually, it's the other way around; the Waveform Injector has made an exact duplicate of the violin waveform using the triangle waveform of figure 1.

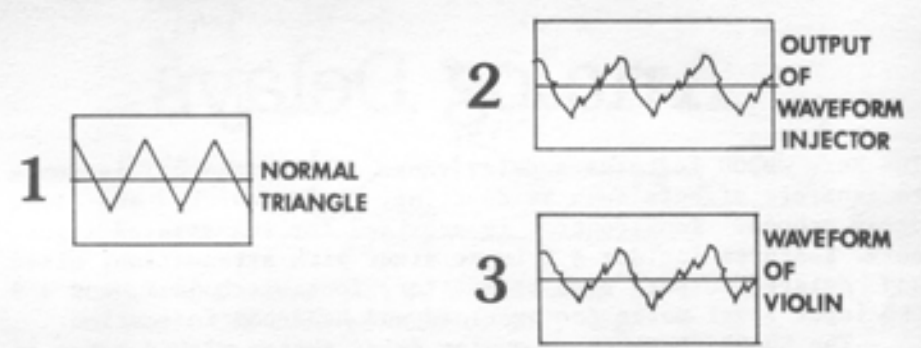

How did the Waveform Injector process the waveform in figure 1 to come out being the waveform of a violin? Refer to the block diagram in figure 4 to make things a little easier

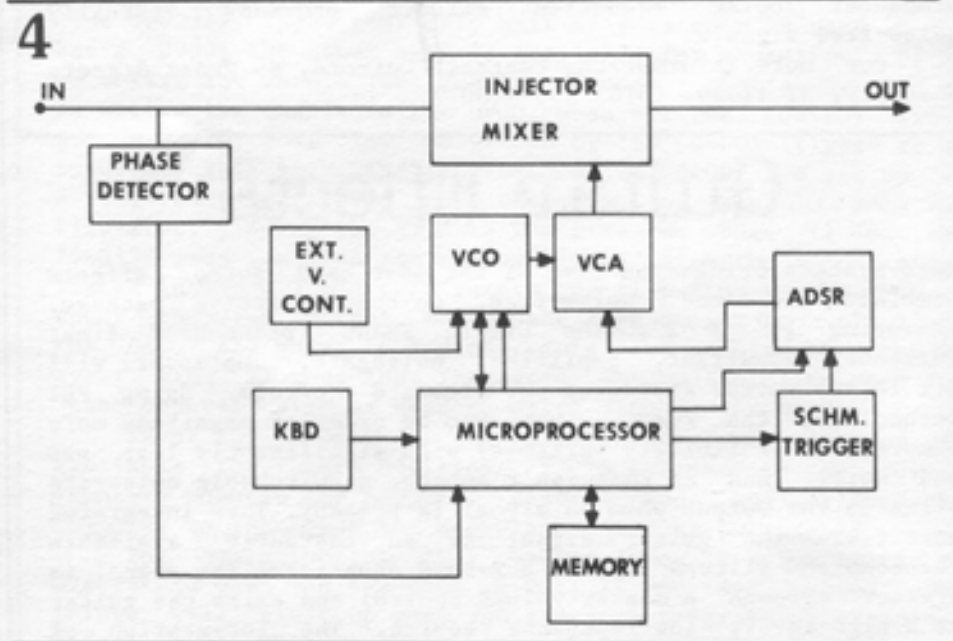

CYBORTAR

(A STRANGE NAME FOR A STRANGE INSTRUMENT)

DESIGNED AS A SELF CONTAINED EXPRESSIONAL MUSICAL INSTRUMENT WITH THE MOBILITY OF A GUITAR AND SOPHISTICATION OF A SYNTHESIZER. WITH A REASONABLE AMOUNT OF PRACTISE, THE USER WILL BE ABLE TO CREATE MIND BOGGLING MUSIC EXPRESSIONS.

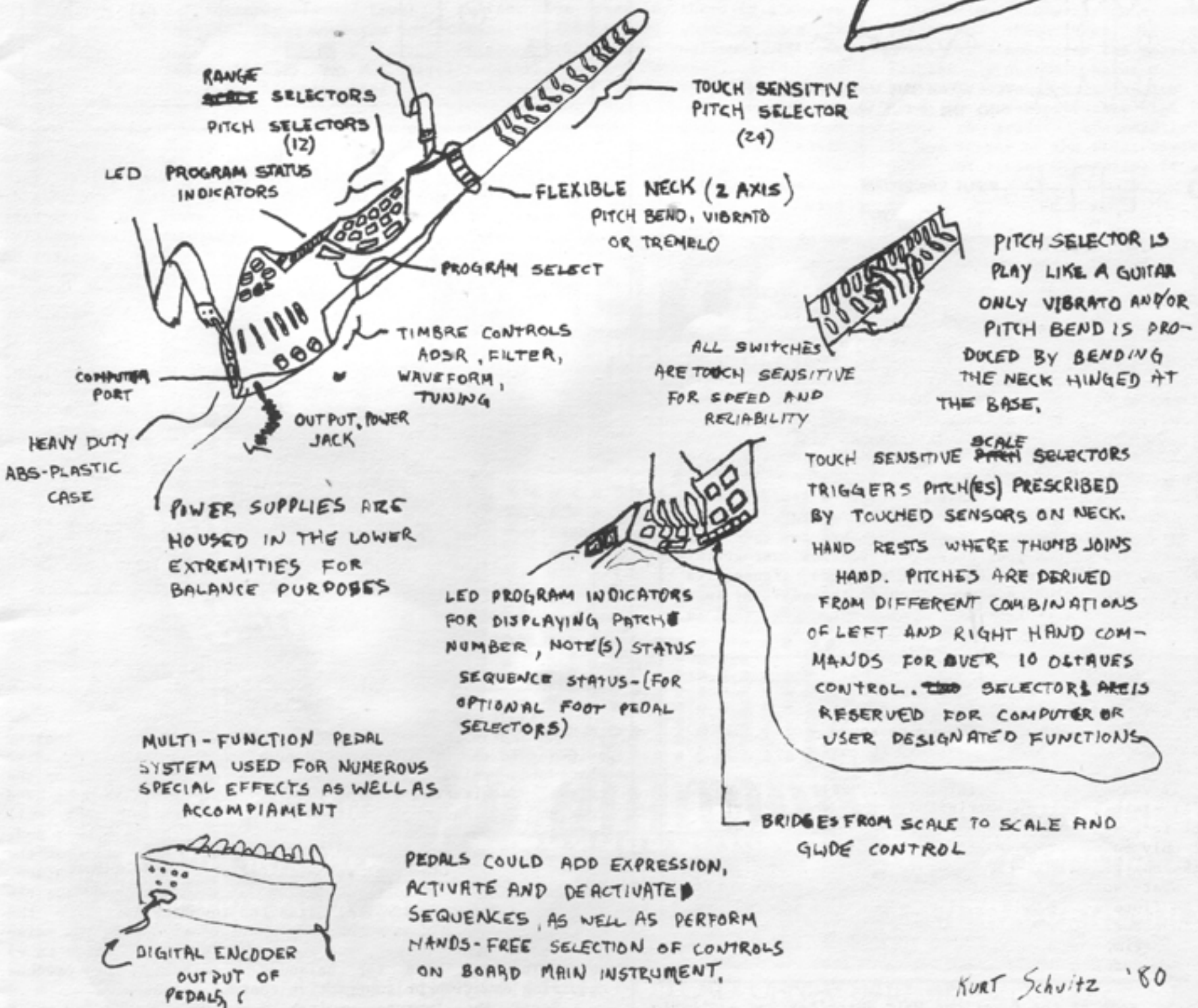
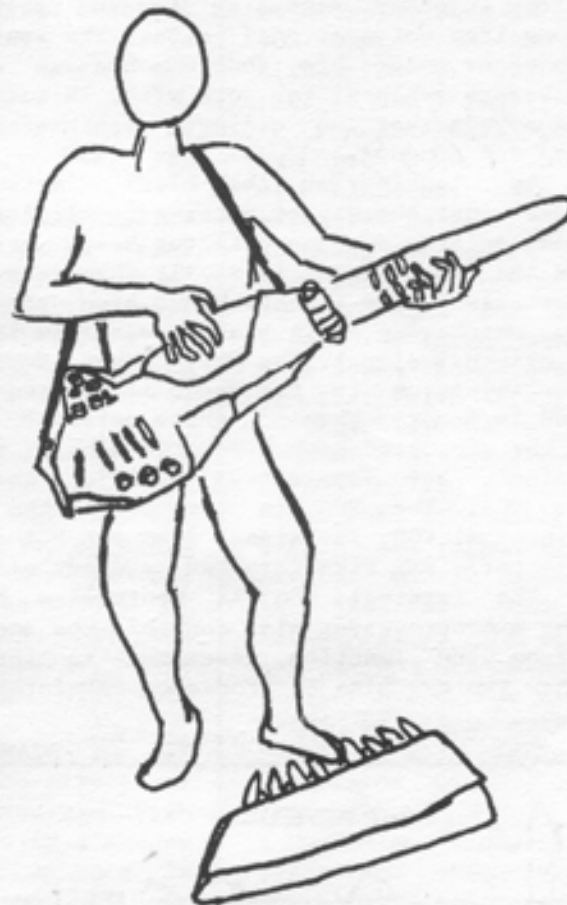

KURT SCHULTZ '80

to understand. First, the synthesist must decide what waveform he wants to process. A triangle waveform usually works best. He then looks up a chart of given acoustic instruments and programs the Waveform Injector according to the particular sound he wants. One item not mentioned is that the synthesist with a Waveform Injector under his control has an endless assortment of waveform shapes to work with. This leads to totally new unique sounds that no ordinary synthesizer (or natural instrument) can produce.

Internally, by looking at the block diagram, the circuitry is not new—just the way of putting it all together. First, as the signal enters, a phase detector keeps track of what phase degree the input signal is at. It then relays this data to the microprocessor. The processor has been previously programmed as to which degree in phase a waveform is to be injected onto the original signal. The key phase degree on which a specific injection is to occur is entered by the keyboard and stored in memory. When the phase detector relays the key degree, the microprocessor fires the Schmidt trigger which controls a simple but fast-acting function generator which controls a VCA. The VCA in turn passes the signal generated by the internal VCO. The signal from the VCA is then applied to the injector/mixer circuitry and summed with the original input. The internal VCO is controlled by the microprocessor. The microprocessor also controls the amount of control voltage from the function generator to the VCA. Figures 5 and 6 show two examples of processed waveforms.

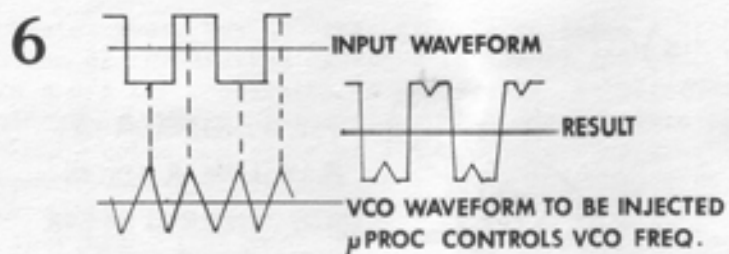
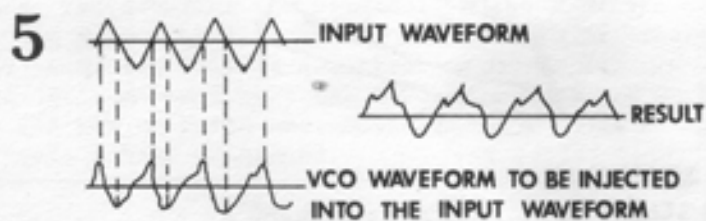

There can be a lot of options available too. For some ideas, how about complete external computer control? (Interface to an Apple or IMSAI micro-computer.) For another idea, how about a waveform analyzer/duplicator which would allow a musician to plug a microphone into the Waveform Injector and have it duplicate the waveforms from the microphone.

Figure 7 shows approximately what a typical Waveform Injector would look like. Most of the controls speak for themselves. The controls on the far left are for the internal oscillator. The center group of push-buttons are for the internal microprocessor and control. The group of controls to the far right are input and output jacks, as well as a few LEDs to indicate problems or incorrect programming. This is my conception of the ultimate module."

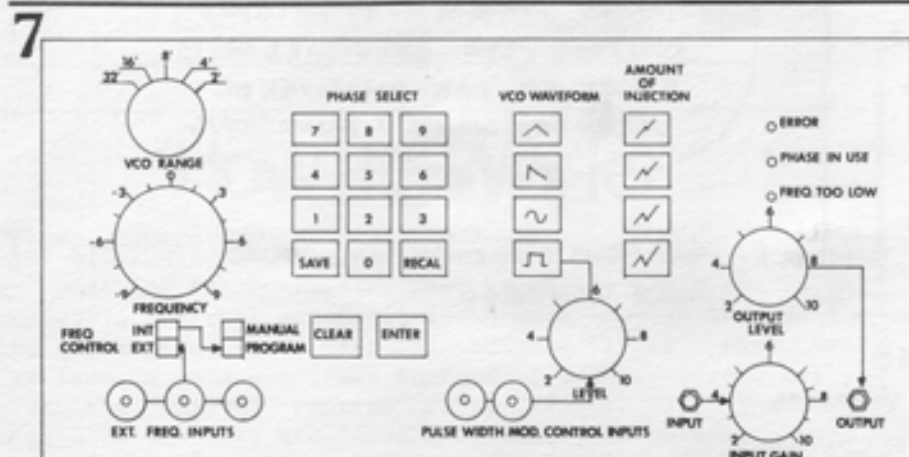

While some of the functions Walt describes are available on such instruments as the Fairlight or the Resynator, it

seems tremendously appealing to have an 'add-on' to provide these functions for existing analog equipment.

Clever ideas for new ventures quite frequently can be derived from existing or outmoded concepts which have been forgotten with technological advances. I guess the 'Back To Basics' movement can apply to high technology areas like electronic music as well as daily lifestyles and housing. Such is the case with Michael Buck's THEREMIN CONTROLLER.

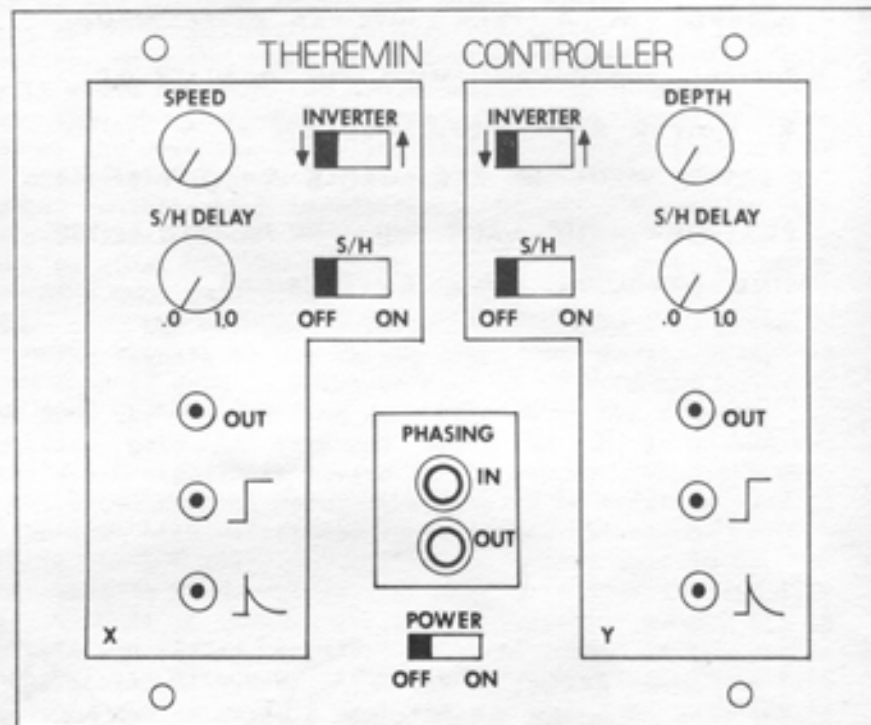

"If you're not very good on keyboards but like to impress with effects, try the Theremin Synthesizer Controller. This unique device may be used either with or without a keyboard. With a wave of a hand you have control over two parameters called X and Y outputs. These two outputs have either positive or negative voltage outputs, which can be controlled simultaneously by the amount of capacitance between your hand and a metal plate.

The outputs may be used to control VCAs, VCOs, etc. Use the pulse and step trigger for ADSR, AR Filter, etc. Audio input and output jacks are provided for the use of volume control; or a phase shifter, using X axis as speed control and Y for depth. The following describes a simple hook-up, which is just one of the infinite ways to use the controller.

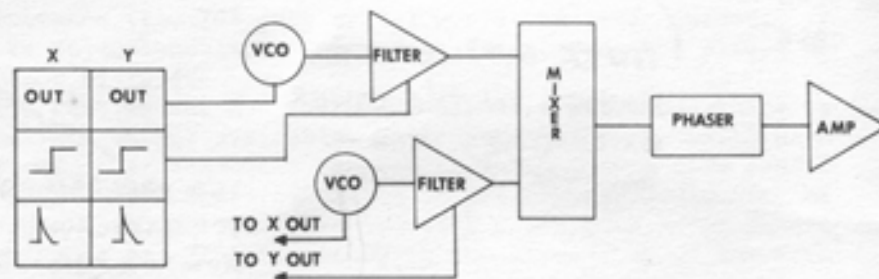

Connect the patch shown. Turn the four controls CCW and put the S/H switches in the OFF position. Slide the Inverter switches to the UP position. To play, turn the module ON, then place the palm of your hand over the X pad touching the trigger pad with the tips of your fingers. Now raise your hand from the pad and the voltage from the output jack will increase from 0 to +5 volts. The same goes for the Y pad. Slide the inverter switch to DOWN. With your hand still at the bottom of the pad, the opposite effect will take place. Starting with +5 volts, raising your hand decreases the voltage or pitch to 0 volts. Slide the Inverter switch to the center position and no sound should emerge since, as you raise your hand, the voltage out goes negative from 0 volts to -5 volts. This is used for balanced modulation, or patches requiring negative or subtractive control voltages.

Reset the Inverter switch to the UP position for the X pad. Rotate the trigger delay control to .5 second, then touch

the X trigger pad with the tips of your fingers and raise your hand up and down. This puts a time delay on the sample/hold circuitry allowing a change in pitch without a glide effect. Rotate the trigger delay control back to 0 and turn the S/H switch on for the X pad. Place your hand on the Y pad and hold it there. Using your other hand, touch the X trigger while slowly raising your hand from the pad. When you reach a specific output voltage or pitch, remove your hand from the Y pad. Foot switches may be used for the HOLD function instead of a hand. The Inverter switches can be used in the S/H mode.

The pulse trigger is momentary and the step trigger is constant until your hand gets out of the range of the X or Y pad.

The Speed and Depth controls may be used if the S/H switches are off. Feed an audio signal into the input jack from a mixer, filter, etc., and send the output to an amplifier."

There are many cases of advanced techniques of music synthesis which are eventually explored by long-term synthesists, but which would make excellent tools for introductory synthesis as well - if only the tools were readily available in other than large studio systems. Wilson Bent's WAVESHAPE SEQUENCER is certainly not a new concept in itself; however, applied as he proposes, it would become an innovative and creative addition to the realm of lead and educational model synthesizers.

"In my studies at the Berklee College of Music, I have experimented with sequencer-generated waveforms. I have achieved very satisfying results both by setting up a 'constant' waveform and by varying the shape while playing. The sequencer at Berklee is the ARP Analog Sequencer, interfaced with either a 2600 or a 2500. The main advantage of the ARP Sequencer is the use of linear pots, which allow you to see your waveform at a glance (as compared to regular rotary pots).

Although I have used the full 16 steps for waveshapes, I've found that 8 steps are sufficient for most uses and are easier to alter during playing. In addition, using the Reset switch connections to create a 4 step waveshape is handy for quick octave transposition. 4 steps is a limited number in regards to waveshaping, but not overly so.

One necessity I've found is a tone control; the sharp edges created in going from one level to another can create annoying harmonics. If it is the only audio signal source used, i.e. no other VCOs, the VCF can be used. However, I would like to see a separate tone control.

Since the sequencer is driven by a VCO whose frequency is subsequently divided by 8 (or 4, or 16), it requires high frequency stability; a driving frequency of up to 20 KHz or more may be needed. What I would like to see is a dedicated waveshape sequencer in a hard-wired synthesizer, such as the Odyssey."

There is always something to be said for simplicity and 'stating the obvious'. The entry from Chris Meyer presents something which we should all relate to, as well as being something which you think would be possible with our 'miracle space age technology'.

"I dream of a synthesizer system that never breaks down - 100% reliability. I think that fulfills the 'currently not available' clause - at least to hear some talk, it does."

There were many other interesting ideas submitted. Perhaps we can review additional entries in later issues. There were several 'processor based systems; one closely resembled an ARP Quadra, several resembled Prophets and OB-Xs. Several readers recommended programmable parametric equalizers- a good idea, but available for some time now from several manufacturers. Variable Slope filters, extremely valuable and neglected items within the industry, were mentioned only briefly. A programmable patch bay, computer waveform analysis and reproduction, brain wave control, digital delay lines with a new feature here and there, dual phasers, pitch detector computer input interfaces, a BOING ADSR (which ripples after transitions), a signal cross-fade unit, and Hall Effect keyboard on which you can do glide with a magnet are representative of the remaining entries.

Even though the contest is over, don't hesitate to submit additional ideas as Letters to the Editor. Polyphony is always interested in knowing what our readers feel is needed for the creative work they are doing. And who knows, perhaps a manufacturer will see your idea and incorporate it in their next product! 4

EKx Series Exponential Module Cards

Featuring
CES Audio/
Synthesizer IC's

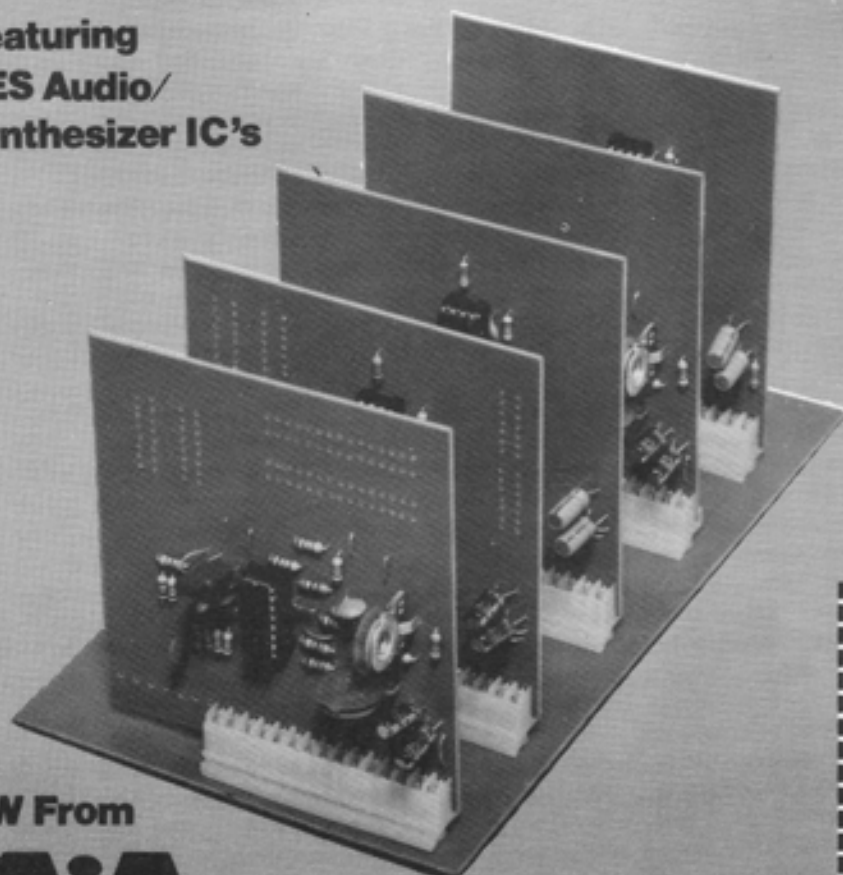

EKx-10 ADSR

envelope generator with exponential control of Attack, Decay and Release times over a guaranteed .002 to 20 second range. No control voltage feed-through.. \$24.95 plus postage (\$1.00)

EKx-20 VCF

with exponential control of pole frequency over a 10 octave range. Jumper programmable for 24 dB/Oct. LP, HP, BP or All Pass response. Voltage controlled resonance. Low noise, 86 dB below max. output. \$26.95 (\$1.00)

EKx-30 VCA

low noise, low distortion, wide bandwidth, low control voltage feedthrough. Both exponential and linear control voltage inputs simultaneously available..... \$24.95 (\$1.00)

EKx-40 Full Feature VCO

Full feature VCO with ramp, triangle and voltage controlled pulse. Exponential control of frequency over accurate and stable 100,000:1 range. Linear FM input and hard and soft sync. \$29.95 (\$1.00)

Each kit features the Curtis Electromusic I.C.'s to implement a full function Voltage Controlled Card. All connections are brought to the card edge in a configuration compatible with Molex or 22 pin .156 center edge connectors.

SEND EKx10 EKx20 EKx30 EKx40; \$_____ enclosed.

TELL ME MORE, Send set of 4 IC spec. sheets; \$1 postage & handling enclosed.

SEND FREE CATALOG

name: _____

address: _____

city: _____ state: _____ zip: _____

NEW From

RAIA
ELECTRONICS, INC.

Dept. 1-Y 1020 W. Wilshire Blvd.,
Oklahoma City, OK 73116

E-COMP PROJECTS

DYNAMIC PHRASING

BY: KEN PERRIN

This is a new column for Polyphony. Like other columns, this one deals with construction projects. Unlike other columns, the result of the construction project is not a piece of hardware but, maybe, a piece of music.

But before we start the first project, let's lay some ground rules. Fundamental to the thrust of this column is the idea that composing music is primarily a craft. Anyone having sufficient determination to learn the associated technique can create a reasonably good piece of music. Of course, not everyone can make an outstanding piece. To make a truly good piece requires not only compositional craft but also musical art. While it may be possible to learn the art, it seems doubtful that it's possible to teach it--and it seems certain that it's impossible to learn it in a magazine article.

The second ground rule is that making a piece of music does not require inspiration. "Waiting for inspiration" is an excuse used by too many musicians who are trying to postpone working at making music. If inspiration were the germ of composition, music curricula would be filled with courses like "Intermediate Walking in the Woods," "Packing a Picnic Lunch 101," and "Seminar in Cloud Watching." Absurd? Definitely!

Although these kinds of experiences may create a certain state of mind in which an artistic endeavor seems to be the correct response, these experiences cannot, in themselves, assure that the resulting music will be any good. Further, there is no reason to expect that successive pieces will be any better than the first efforts. Operating under the "composition by inspiration" method has other pitfalls, notably--can one judge the music without also passing judgement on the quality of the experience from which it resulted? Although you may have been moved by an experience, your music which you've done as a response may be drivel. Calling it drivel is not a reflection on the quality of your original experience; which brings us to the next ground rule.

Some music is drivel. Some of mine is drivel and, face it, so is some of yours. "Who says so!" you demand. "I do, and if you'd step outside of yourself you'll know it too." Listen to your music as critically as you listen

to your friends' music; listen to it objectively. It requires at least two people within you to make a piece of music; one of you does the piece and the other of you judges whether or not it's any good.

Our penultimate ground rule is that most of the construction projects won't work. That is, most will not produce what you might call a personally satisfying piece of music. But then their purpose is to isolate some musical techniques and give you a chance to practice them. With your own ideas (and hopefully, you increased technical facility) you can create the music. It's a fact, the more fluent your technique the better and more imaginative becomes your music.

Our final ground rule is that these studies are atonal and ametric. Pitch and meter are musical details and concentrating on these details often obscures more fundamental elements like form and structure. We've chosen, first, a simple project which was used as a first project at the Boston School of Electronic Music. Here are its limits.

Using a maximum of four audio frequency sine waves and controlling their frequency and amplitude only manually (i.e. with the pots) create a piece 60 seconds long which has one crescendo and one diminuendo. Now stop and think for a moment before reading on. Consider what the important problems are and consider a variety of solutions.

First of all, it seems that the basic problem is "How do I create a crescendo?" But an even more basic problem is "What is a crescendo?" After all, there's more to a crescendo than turning up the volume. Next, consider where within the 60 second time limit you should put the crescendo. In passing, you might consider why you should not put it some other places. Finally, consider the pitch and the amplitude of the four sines. Although exact pitch is not important here, approximate pitch can be significant. (Not making a formal definition, but "approximate pitch" is something like describing a pitch as "very high" or "sort of mid-range.")

So then, it appears that even though the problem seems simple at first, on closer scrutiny a number of equally plausible solutions become

apparent. Choose the solution which you feel makes the music move forward in time. That last sentence holds an important thought and is worth repeating in another manner. Your music should provide the listener with cues to lead him/her from one point in time to the next. It is as if you are leading the listener across a stream by pointing out where the stepping-stones lay. The goal here is to provide an interesting excursion from one side to the other--from the beginning to the end of these 60 seconds.

Unless your music moves forward in time, it is static, dull, and boring. It does not delimit the passing of time. But back to the more immediate problem--the crescendo.

Think about how a crescendo works. It works by increasing the amount of tension; it is analogous to taking in a deep breath. Of course the implication of the analogy is that it should be naturally followed by a diminuendo, which in our study, it is. Consider, then, how you can build tension, using the four sine waves. Again, stop and think before reading on.

O.K. then, the description of one possible piece might be like this. The crescendo starts with two sines tuned to unison. As it increases continually de-tune one of the sines, thus increasing the tension. At the peak of the crescendo these two sines should be about a semitone apart.

Just before the peak you can add the third sine at some higher frequency and at the peak introduce the fourth sine at a low and almost rumbling pitch. So that's one possibility, but even with this basic form there are an endless number of variations.

But as you've deduced, the crescendo cannot be isolated from the rest of the piece. It must, instead, be woven into the same fabric as the other sounds and there must be the same thread of an idea strung throughout the piece. The description of this next example is more complex, but it shows the pattern of the crescendo as it appears early in the piece.

Assume that the theme of the piece is a glissando which starts in the mid-range, goes about half an octave higher and then falls about two octaves lower. Further assume that this entire event takes about one and a half seconds. This little motive is

represented, very roughly, by figure one. As the piece progresses, more voices enter, the texture becomes more dense and the glissando changes--it begins to take longer and longer to ascend the half octave than it does to descend the two octaves. This development in the motive is shown as figure two. Finally at the crescendo, each voice climbs slowly and continues to climb. The crescendo works because the tension increases as the listener waits for the inevitable fall. You see, you've prepared the listener by leading him/her slowly to this point. Finally, when the fall occurs, it's the inevitable and awaited conclusion--it provides the complementary release to the tension.

You see, by developing the theme as described, we make a statement about how time will pass for these 60 seconds. We say, specifically, that the fundamental unit by which time is reckoned is our little motive. Furthermore the development of this figure implies that as we progress further and further into this 60 second time period the fundamental unit will change in a predictable manner. Up until the crescendo, we reinforce that expectation. But at the crescendo, we stop time. We lose the sense of motion which we have established. At this long upward glissando we've distorted our basic unit, not beyond recognition, but

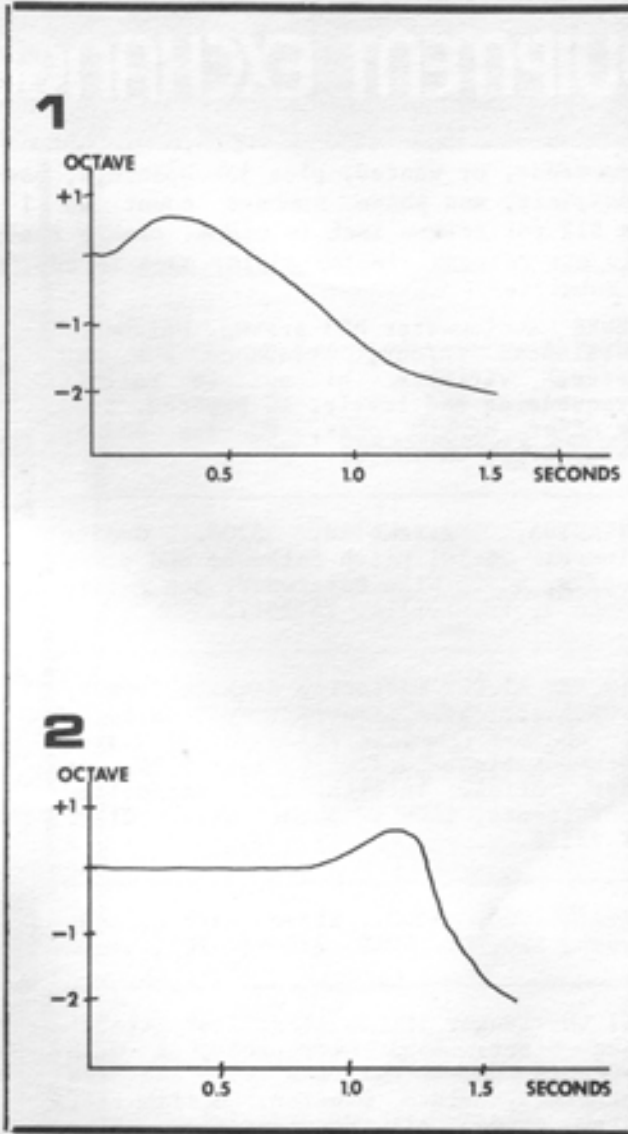

beyond any usefulness as a yardstick to measure passing time.

Obviously there are many other solutions. Come up with a few on your own then choose the best one and make a piece out of it. It is the kinds of ideas that you will probably come up with that will provide themes for later pieces, but for now learn to work with them so you can make the sounds do what you need them to do. Keep in mind that almost everyone has great artistic ideas, but only a few people have the technique to implement them and even fewer have the determination to try.

It's an interesting story and so I tell it over and over. In closing, I'll tell it here.

A few years ago, I gave this same project to a group of seven people. Six of them decided that the peak of the crescendo should go somewhere between 35 and 40 seconds into the piece. The Fibonacci division of 60 seconds is 37.5 seconds, but none of the people involved were aware of this at the time. Each person made the decision of where to put the crescendo intuitively, yet it roughly corresponded to the Fibonacci division.

In fact, the Fibonacci series has been used by a goodly number of artists and by some notable composers,--among them Bartok and Stockhausen. In the next construction project, we'll take a look at the series and at least one way you can use it in your music.

Advertiser Index

AJK Electronics	4
Dickstein Distributing	29
Godbout Electronics	4
Octave Plateau Electronics	31
Paia Electronics	27, 32
PolyMart	15, 16-17, 18
Serge Modular Music	7
Southwest Technical Products	2
Speaker Builder	19
Synergetics	30

When You Write To Our Advertisers,
Tell Them You Saw Their Products in

POLYPHONY

BY PROFESSIONAL DEMAND

DDC OFFERS FREE ADVICE, PERSONAL SERVICE AND ONE-DAY SHIPPING OF THE FINEST MUSIC AND SOUND EQUIPMENT AVAILABLE ANYWHERE:

PLEASE CALL OR WRITE FOR PRICES & ORDERING INFORMATION - YOU'LL BE GLAD YOU DID!

DDC DICKSTEIN DISTRIBUTING COMPANY
1120 QUINCY PPY-SCRANTON, PA 18510
PHONE ORDERS WELCOME: (717) 344-7469

EQUIPMENT EXCHANGE

List your equipment or services for sale, trade, or wanted, plus job openings, positions wanted, and so on. Keep listings brief; enclose \$1.00 for each 10 words. Prices, zip, and phone numbers count as 1 word each. Display classifieds are available for commercial ads; rates are \$12 per column inch (minimum, camera ready). Respond directly to the advertiser. Please don't write to POLYPHONY. Polyphony is not responsible for claims made in ads, or the results of any transactions. We reserve the right to edit or refuse any ads submitted.

Music equipment

SEVERAL ARIES, CFR (exponential) and PAIA type modules, good condition, reas. priced, 3 octave Hammond keyboard in walnut cabinet. SSAE for details. Jim Rice, 577 33 Rd., Clifton, CO 81520.

STRINGZ & THINGZ: Less than 1 year old. Mint condition. Must sell. \$350. Don Montavani, 203-469-8511, evenings.

ROLAND MC-8 Micro Composer. Computer control 8 analog synthesizers. Sync to multi track recorder for unlimited number of polyphonic voices. List: \$5,995. One unit only at \$3,125. Also have stock of Roland System 100M synthesizer modules at discount. Craig G. Ingle, 11057 8th Ave. N.E., Seattle, WA 98125, (206) 367-6800.

4710, 4730, 4740, 4761, 2720-1, -5, -7, preamp (Anderton), patch cords, Ping Pong and Synthespin MkII. Assembled and in good working condition. Complete package at 1/2 price, \$125. I will ship insured. Neil Blatnick, 8613 Brookridge Dr., Ft. Worth, TX 76118, (817) 485-3520.

SHURE Audiomaster M63 preamp, balanced/unbalanced in/out, headphone out, VU meter, variable hi and lo rolloff frequencies and levels, AC powered. \$100 or offer. Marvin Jones, PO Box 20305, Okla. City, OK 73156. x

ORGANTUA, assembled, \$200. Gentle Electric GE-101 pitch follower and power supply, \$250. Mike Underwood, Box A-594, Route 3, Troutville, VA 24175.

PIONEER RT2022 mastering deck, 1/2 track, 7.5/15 ips, sync, modular: expandable to 4 channel multitrack. Mint, with documentation and accessories: \$1000 or best offer. Entertainment Technology Consultants, 2600 NW 30th, Okla. City, OK 73112. x

PAIA 4700C, \$300. Steve Latham, 105 Arden, NYC, NY 10040, 212-567-2012.

OSI Challenger 1P: (Will sell or trade-make offer) 6502 microprocessor with Basic in ROM, 8K RAM, built-in cassette interface, video monitor, muffin fan, patch cords, all documentation plus EXTRA books. Like new, has seen careful, marginal use. \$500. David Vosh, 529 S. Frederick Ave., Gaithersburg, MD 20760, 301-869-4931.

4700C - New, never used, fully assembled, factory tested, tuned, and aligned. You pay the kit price (\$325) and I pay the shipping, factory charges, etc. R D Haig, 766 Country Club Rd, Bridgewater, NJ 08807.

MINIMOOG, modified for cv and gate outputs, new Jan 1976, needs new keyboard (tarnished contacts), otherwise excellent condition, \$500. Peter Krauss, 1533 NW 25th, Oklahoma City, OK 73106, (405) 524-2539.

P4700C synthesizer, computer fully loaded with RAM, MUS .01, extra 4720 VCO and Quash, \$400 plus shipping. Gnome microsynthesizer, \$40. Contact: SP5 Timothy H. Schmidt, Supply & Maint. Co., CMR Box 57, APO NY 09458.

Unique Fully Patchable Oberheim 4-voice with programmer. Everything works fine. The only polyphonic patchable programmable synthesizer I've ever heard of. Customizing work done by John Vieira of WAVES in Napa, CA. Best offer. Write or call Devarahi, PO Box 625, Pleasant Hill, OR 97401. (503) 747-3551.

PAIA kits assembled, some need work. Oz \$50, Gnome \$40, Phlanger \$45, 4710 \$15, 4770 \$10, Pear Productions, 1234 Oak Bark Dr., St. Louis, MO 63141, (314) 872-7257.

SWTPC 2AS-A Stereo Analog Delay, factory assembled, unused, users manual. \$200. Entertainment Technology Consultants, 2600 NW 30th, Oklahoma City, OK 73112. x

4700/S, Phlanger, Programmable Drummer, and Oz mini organ. All need some work. \$300 buys all. Merle Arnold, Box 115, Alma, IL 62807, (618) 547-7610 after 5.

Services

HARMONIC ELECTRONICS: custom synthesizer modifications, electronic keyboard repairs, interfaces, sequencers. By appointment only. Jim Gieske, 216 Gotham Ave., Elmont, NY 11003, (516) 328-9257.

WE'VE GOT BBDs! MN3005- 4096 stage BBD, MN3010- Dual 512 stage BBD, SAD-1024, CMOS (CD40106 Hex Schmitt Trigger and many more), LM723 voltage regulator, CA3080E OTA. Great Prices! Catalog and ap sheets due out soon. For more info: E Systems, Box 5305, Berkeley, CA 94705. x

Recordings

Original Pop/Rock Songs by Walt Whitney on self-produced C-60 cassette. Also contains synthesizer piece entitled "Caverns". Send \$5.50 ppd. to "Tape", 2323 Woodson Rd. #D, Overland, MO 63114.

Literature

PLANS for professional type audio mixer from basic two channel to exotic multi-channel stereo with options. Hi/Lo impedance inputs/ outputs. Great for multi-channel recording/ mixdown. Made from common parts (xfurless). All plans and ideas included. Send \$10 check or MO made out to: Philip Hampton, Box 121, San Carlos, CA 94070.

Wanted

PAIA MODULES: working or unassembled, 4730s, 2720-4s, 2720-11s, 2720-12s. Write: Creative Rediffusions, 7019 Big Daddy Drive, Panama City Beach, FL 32407. 4

PROFIT from your tech or computer know how
DON LANCASTER'S INCREDIBLE SECRET MONEY MACHINE



tells how

\$7.50

Autographed and Postpaid

SYNERGETICS
BOX 1077-P
THATCHER, AZ 85552

() Send _____ ISMM's () Check () Visa
() Send **FREE** Lancaster Booklist

Name _____

Address _____

City _____ State _____ Zip _____

Visa _____

Exp. ____ / ____ Signature _____

Support Our Advertisers ...

the CATSTICK synthesizer controller

THE BETTER ALTERNATIVE TO WHEELS, RIBBONS, PRESSURE PADS, KNOBS, SLIDERS AND PEDALS, FOR ANY PATCHABLE SYNTHESIZER

WHAT IS IT?

The CATSTICK is a precision, spring-loaded joystick controller that lets one hand control four different modulation settings - one for each of the joystick directions. By moving the stick off axis, combination modulations of different proportions are possible. When the stick is released, it springs back to its vertical, zero modulation position.

HOW DO YOU USE IT?

For portable synthesizers, like the CAT, Odyssey, or Minimoog, you can connect the CATSTICK outputs to the VCO, VCF or VCA inputs normally intended for footpedal controls. This lets you use the CATSTICK LFO's and control voltages to modulate the synthesizer as the joystick is moved. In patchable systems like the ARP 2600 or Modular Moogs, you can connect the CATSTICK VCA's in series with patchcords to allow real-time control of synthesizer patches.

WHO CAN USE IT?

If you own a MINIMOOG, CAT, KITTEN, ODYSSEY, 2600, OBERHEIM, MODULAR

SYSTEM or any other synthesizer with control voltage inputs, you can use a CATSTICK. And, if you don't have control voltage inputs or want more, we'll show you how to modify your instrument or do it for you at a very modest cost. We can also modify your synthesizer for "single cable" connection to the Catstick outputs.

PATCHING VERSATILITY

Included are four VCA's (each externally accessible), two wide-range LFO's with rate monitors, and a complete internal voltage processing system. The twenty-jack rear panel patch bay allows access to all of the internal control voltage signals and makes the CATSTICK a versatile addition for both performance-oriented and studio synthesis systems.

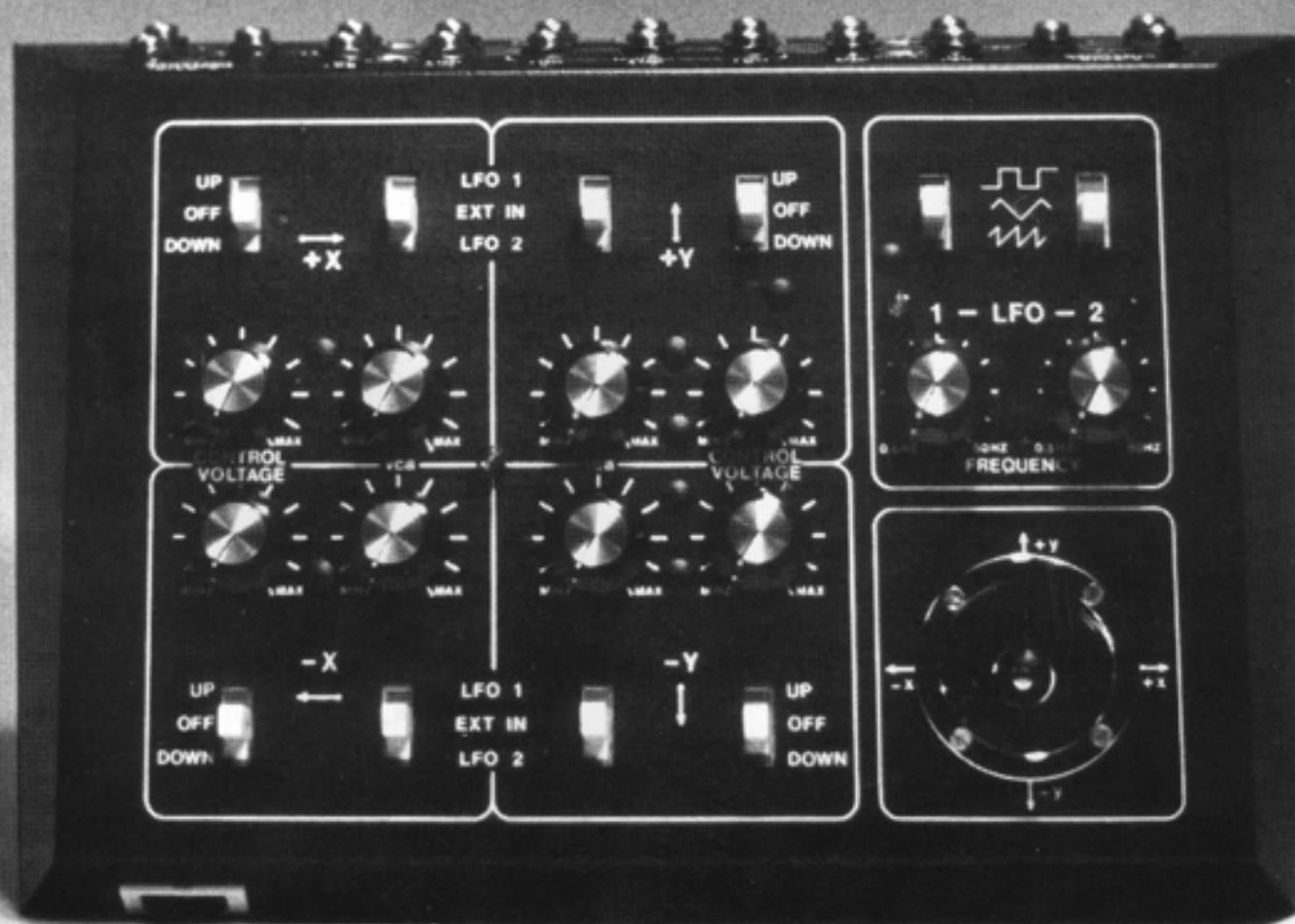
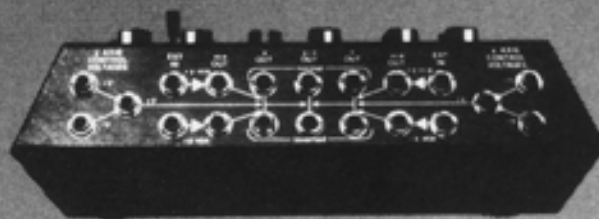

For further information, and the location of your nearest dealer, write:

OCTAVE-PLATEAU
Electronics Inc.

928 BROADWAY, 7th FLOOR, N.Y.C., N.Y. 10010
OR CALL (212) 673-4205

- () I'M SOLD, send the 8750 kit, \$399.00 enclosed.
- () Send the 8750 assembled, \$499 enclosed.
- () TELL ME MORE, send the 8750 Assembly & Using manual, \$10 enclosed.
- () Send FREE Catalog.

VISA/MC no: _____
 exp. date: _____
 name: _____
 address: _____
 city: _____
 state: _____
 zip: _____

PAIA Electronics, Inc., Dept. 2-y 1020 W. Wilshire Blvd., Oklahoma City, OK 73116

NEW FOR THE '80's

FROM **PAIA**

PROTEUS I T.M.

PROGRAMMABLE PRESET LEAD SYNTHESIZER

- 3 octave encoded keyboard with computer port
- 16 programmable presets with ni-cad battery backup
- Preset data and address port provided.
- Liberal patch over hardwire points on rear panel
- Absolute minimum point to point wiring for easy kit assembly and high reliability.

- 2 exponential VCO's; sine, triangle, ramp, square and modulated pulse waveforms.
- Sync provided on oscillators
- Noise source
- Exponential 24 dB/octave low pass voltage controlled filter
- Wide range low frequency modulation oscillator
- Wide range ADSR envelope generator

Even without the programmable presets, PROTEUS would be one of the nicest lead synthesizers around. Its well planned normalization scheme allows direct access to a wide range of effects and sounds, and for those times when no normalization could let you get the voice you're after, PROTEUS's rear panel provides enough patch over hardwire points for modular versatility.

PROTEUS's easy to use programming system for up to 16 presets is the finishing touch. Two buttons control it all:

ADVANCE — press once to step from one preset to the next. Press and hold to scan through presets. Seven segment display shows preset in effect.

PROGRAM — one touch and you punch into the front panel. As you set up the voice you want, PROTEUS's internal memory remembers the control positions and assigns them to the preset number shown in the display.

PROTEUS's features go on and on. Nickel-Cadmium power back-up allows presets to be stored for a week or more without power and recharge automatically when PROTEUS is plugged in. Easy to use computer interface ports allow connection to external controllers for sequencer operations, extended storage of presets, etc. Rear panel provisions for joystick pitch bend or modulation controls. And lots more.

QUESTIONS? How easy is it to assemble? How powerful and versatile? What are the interfacing details? The PROTEUS USING/ASSEMBLY MANUAL set answers these questions and many more. Price — \$10.00 refundable upon purchase of the 8750 kit or assembled model.

No. 8750 PROTEUS Kit \$399.00 (shipped freight collect)

No. 8750-A PROTEUS Assembled \$499.00 (shipped freight collect)



PAIA Electronics, Inc., 1020 W. Wilshire Blvd.,
 Oklahoma City, OK 73116 - (405)843-9626