

POLYPHONY™

ELECTRONIC MUSIC & HOME RECORDING

Jan./Feb.

1981

\$2.50

ISSN:0163-4534

BUILD:

QUAD SEQUENTIAL SWITCH

PULSE WIDTH MULTIPLIER

MAGNETIC HARP

50 WATT/CHANNEL STEREO POWER AMP

AUDIO CIRCUIT BREAKER

SPECIAL EDITION



SWT ANALOG DELAY



INTRODUCING... TWO-CHANNEL ANALOG DELAY UNIT FOR AMBIENCE SYNTHESIS AND DELAY EFFECTS

FEATURES

- * TWO INDEPENDENT CHANNELS
- * 3072 STAGES OF DELAY PER CHANNEL
- * ADJUSTABLE INPUT AND OUTPUT LEVELS WITH INPUT OVERLOAD INDICATION
- * INTERNAL OR EXTERNAL VOLTAGE CONTROLLED DELAY TIME
- * COMPANDOR IN EACH CHANNEL
- * 3 MODES/CHANNEL WITH ADJUSTABLE MIX
- * CONVENTIONAL REVERB OUTPUT FOR MUSIC EFFECTS

If you haven't heard what analog delay can do for home music reproduction, you're missing something. Let's face it, stereo in your living room is flat and

2 dimensional. Without the mixture of direct and delayed sounds that a large hall provides, almost all music reproduced in the home is lifeless. Quadraphonics has not proved to be the solution to this problem. The recent development of bucket-brigade semiconductor technology has made it possible to offer a reasonably priced delay unit that can transform your listening room into a concert hall. Using your present stereo system, the 2AS-A, and whatever you have in the way of 2 additional speakers and 2 channels of power amplification—you have all the parts to put together an ambience system that is capable of creating the kind of 'space' you enjoy music in. You don't need state-of-the-art componentry to enjoy an ambience system. The secondary power amplifiers and speakers can be of very modest perfor-

mance and yet still serve to create strikingly realistic spaciousness in your listening room. If you don't have 2 extra power amp channels on hand, we offer several low cost, low power amps in kit form that would be ideal for this purpose.

Although the 2AS-A has been designed for use in music reproduction systems as an ambience synthesizer, its voltage controlled clock and mixing capabilities allow it to be configured in a number of ways for delay effects such as phasing, flanging, chorus, and vibrato. External voltage control for special effects must be user supplied.

The 2AS-A is sold in kit form only and includes the circuit boards, components, chassis (11½" x 10" x 4"), cover 120VAC power supply, assembly instructions and application notes.

2AS-A Analog Delay Unit
\$250.00 ppd. Cont. U.S.



Southwest Technical
Products Corp.

219 W. Rhapsody, San Antonio, Texas 78216

London: Southwest Technical Products Co., Ltd.
Tokyo: Southwest Technical Products Corp./Japan

MAIL THIS COUPON TODAY

Enclosed is \$ _____ or BAC # _____

or Master Charge # _____ Bank # _____ Expire Date _____

NAME _____

ADDRESS _____

CITY _____ STATE _____ ZIP _____

SOUTHWEST TECHNICAL PRODUCTS CORPORATION
Box 32040, San Antonio, Texas 78284

STAFF

PUBLISHER
John S. Simonton, Jr.

EDITOR
Craig Anderton

MANAGING EDITOR
Linda Kay Brumfield

ART DIRECTOR/
PRODUCTION MGR.
Cynthia Rueb

CIRCULATION
Ramona French
Peggy Walker

BOOKEEPING
Cathi Diehl

PRINT PRODUCTION
Donald "Dinky" Cooper
SEMCO Color Press

POLYPHONY (ISSN 0163-4534) is published bimonthly at 1020 W. Wilshire Blvd., Oklahoma City, OK 73116, by Polyphony Publishing Co. Entire contents copyright (c) 1980 by Polyphony Publishing Co. All rights reserved. No portion of this publication may be reproduced in any manner without written permission from the publisher. Controlled circulation postage is paid at Oklahoma City, OK 73125.

ADVERTISING rate card and deadline schedule is available upon request. Contact Linda Brumfield at (405) 842-5480.

DEALERS & DISTRIBUTORS bulk prices are available upon request. Contact Linda Brumfield at (405) 842-5480.

SUBSCRIPTION rates:
American 1 year \$12.00
2 years \$22.00
Foreign 1 year \$14.00
2 years \$26.00

We now accept MasterCard and Visa payment for subscriptions, back issues, and PolyMart items. Foreign payments must be by charge card, money order, or certified check in US funds drawn on a US bank.

BACK ISSUES are available at \$2.00 each ppd. Send SASE and request our 'Back Issue List' for a complete index of issues and their features, or see the back issue ad in this issue.

CHANGE OF ADDRESS notifications must include your former address and zip code, and any numbers from the mailing label, as well as your new address. When you move, be sure to notify your post office that you DO want second class and controlled circulation publications forwarded. This will save lost or returned issues. Polyphony is not responsible for replacement of lost or returned issues when we have not been supplied with change of address information.

Postmaster, send form 3579 to:

POLYPHONY
PO Box 20305
Oklahoma City, OK 73156
Ph. (405) 842-5480

CONTENTS

ISSN: 0163-4534

Volume 6, Number 4
January/February 1981

CONSTRUCTION & MODIFICATION

External Battery Supply made simple.....8	by Paul Baltzegar
Pulse Width Multiplier.....12	by Craig Anderton
Audio Circuit Breaker.....16	by Doug Montcrieff
Quad Sequential Switch.....21	by Tim Fluharty
Pickup Switching Trick.....24	by Steve Morrison
Dod Mod I: Envelope Follower.....25	by David DiFrancesco
Dod Mod II: Chorus.....25	by Craig Anderton
50 Watt/Channel Stereo Power Amp.....26	by Robert Rafuse
Magnetic Harp.....28	by Richard Wolton
The Normalled, Live Performance 4700/S.....30	by Doug Llewellyn

COLUMNS & REGULARS

Letters (Editor's Note).....4
Polyphony Reviews5
Current Events.....9
Patches14
Equipment Exchange33
Advertiser Index34

NATIONAL
ASSOCIATION OF
MUSIC MERCHANTS



EDITOR'S note



When I heard that Marvin Jones was leaving Polyphony, my first thought was "who will they ever find as a replacement?" Now I know. And I must say, I'm glad to be here.

This issue marks an important step in Polyphony's growth. First of all, we have now picked up the readership of DEVICE newsletter, which folded at the end of 1980 after putting out 12 issues. Unfulfilled DEVICE subscriptions will be completed with issues of Polyphony on an issue-for-issue basis, so DEVICE readers will be getting more pages as well as a more broad-based publication. I would like to welcome all former DEVICE subscribers, and thank you for your dedicated support through some difficult times. I also feel that I must apologize to many readers on behalf of Roger Clay, DEVICE's publisher. Due to a variety of personal and financial circumstances, Roger was suddenly unable to manage DEVICE's business affairs, leaving me with a bunch of "where is my subscription?" letters as well as many other problems that needed to be cleaned up. I have tried to pick up the pieces as best I could, but if there are any remaining difficulties, please write me c/o Polyphony and I'll see what I can do. (I would particularly like to hear from Frank who sent the Echoplex unit; I can find no record of his full name or address.)

In addition to expanding its readership, the second important step in Polyphony's growth is an increased editorial emphasis on guitar electronics and home recording. This does not mean a de-emphasis of synthesis related articles - no way! Rather, this reflects the reality that the traditional lines separating various instruments and disciplines are blurring. Guitarists are using synthesizer modules to expand their sound; keyboard players are modeling alternate controllers on the guitar; and everybody seems to be interested in home recording these days. I think of myself as a pretty typical reader, and I play the guitar, keyboard, and have a home studio. All those subjects are of interest to me, and I'm sure they are of interest to you as well.

There are lots of plans for the future...getting the magazine on schedule is the first priority, and the next step would be publishing 9 issues a year instead of 6. Eventually, I'd love to see Polyphony go monthly. There are also plans afoot for Polymart to market publications specifically of interest to the Polyphony readership - in fact, Polymart will be playing a greater and greater role in providing tools for electronic musicians.

But any dreams must be tempered with a sense of reality. Electronic music publishing ventures do

not have a great track record - Bob Moog put out a quarterly newsletter that folded back in the late 60s; Synthesis magazine disappeared after two issues; Source stopped publishing; Synapse never made it; and now, DEVICE is no longer with us. Electronotes (an excellent publication) is still hanging in there, but is behind schedule. So, why do I have any reason to suspect that things are going to be different this time with Polyphony?

Well, there are some very encouraging signs. This time around, I'll be dealing with a publisher I know I can trust - John Simonton. His dedication to electronic music has kept Polyphony going for 5 years, despite the fact that it has never been a money-maker. We have worked together well as a team on projects in the past, and I expect that we will continue to get along equally well in the future. Also, having one magazine serve all electronically-oriented musicians should help prevent the market-splitting that occurred when Synapse, Polyphony, and DEVICE all existed at the same time. We know now that there's not enough of an audience to support three magazines; but I think there are enough of you out there to keep Polyphony alive, well, and growing. Finally, it is great to become editor of a magazine that has already been publishing for 5 years; instead of having to start from ground zero, we've got a firm base to build on.

There has been much behind-the-scenes work needed to install me as editor, take care of DEVICE readers, and get Polyphony headed in a new and positive direction. I'd like to thank Marvin Jones and all the staff of Polyphony for their help, and particularly thank John for generously offering to take DEVICE subscribers under Polyphony's wing (most magazines just leave their readers hanging when they fold, but I didn't want that to happen and fortunately John didn't either). I hope that DEVICE readers will correctly interpret this gesture as meaning that Polyphony welcomes them with open arms.

Whew! Sorry about being so wordy - but I wanted to let you know what was happening. Polyphony's a fine publication already; we've got the most dedicated and enthusiastic readership any editor could ask for, as well as lots of excellent articles on file. My job is to take this publication even further - and as my friends can tell you, I don't take on any job unless I think I can do it right. It's good to be here, and I hope that all of you will be pleased with Polyphony's progress in the months ahead.

Craig



re-view

by Robert Carlberg

Michael William Gilbert - The Call (Gibex 002)
Gilbert continues his research into contexts for the synthesizer, combining it with flute, sax, mbira, percussion, etc. In the process he creates a stunning "world music", drawing on many cultures, emphasizing the unity in the music worldwide.

K. Leimer - Closed System Potentials (P.O.L. 03/1000)
A cross-fertilization of Leimer's usual Eno-esque tune writing with more-conceptual tapework. Simple 5-note tunes are slowed down and taken apart, leaving Moog, piano, and guitar chords to drift sleepily in a primordial brine.

Marc Barreca - Twilight (P.O.L. 05/1000)
A difficult album to summarize - presents at least a dozen styles of electronic music, yet still maintains a strong coherency. Multi-dimensional tour de force of both keyboard and non-keyboard synthesizing.

Tangerine Dream - Tangram (Virgin 2147)
Rather like eating Chinese food - tastes good going down but you're hungry an hour afterwards. Tasteful fluff.

Cluster - Cluster '71 (Sky 047)
Re-issue of their rare first album. Pre-keyboard, just after Conny Schnitzler left the group - still sounds like Kluster. Hardcore stuff, but well controlled.

H. J. Roedelius - Selbstportrait III (Sky 044)
More organ doodlings 1974-79. One good track, the rest sounds like a promotional soundsheet for Farfisa. No, make that two.

Weather Report - Night Passage (CBS 36793)
Much of the fire seems to have gone - in particular Pastorius could have phoned in his contribution - but it has some moments.

Ann McMillian - Gateway Summer Sound (Folkways 33451)
Tape manipulations of birds, frogs, insects and others. Could have been interesting, but unfortunately develops no contexts outside itself.

Fall Mountain - Early Fall (Parachute P009)
Atonal, arhythmic improvisations for violin, piano, soprano sax and Serge synthesizer. Everyone plays their heart out, but not always in the same direction.

Gordon Mumma - Dresden/Venezia/Megaton (Lovely Music/Vital Records 1091)
Three mid-60's compositions for industrial noises. Some elaborate processing, but not much else. Organized sound without the organization.

Morgan-Fisher (editor) - Miniatures (Pipe 2)
Fifty-one 1-minute tracks by virtually every important English experimental/progressive musician active today. You can't do much in a minute but it is a nifty sampler.

Moebius & Plank - Rastakraut Pasta (Sky 039)
Eccentric German rock. If Roedelius is the harmonic half of Cluster, then Moebius is the quirky rhythmic half. "Zuckerzeit" with a hard edge.

Holger Czukay - Movies (EMI 3319)
Former Can bassist backed by the rest of Can (except Damo). Reportedly a different mix for each country release - the German edition is a Can album ludicrously overproduced.

Bernard Szajner - Some Deaths Take Forever (EMI 14863)
Rude French electro-rock, using a variety of imaginative electronic percussions, sound effects, synthesizer voicings and writing styles. The French answer to Moebius/Plank.

Throbbing Gristle - Heathen Earth (Industrial 0009)
Electronic rhythm box, fuzz guitar, incomprehensible speaking, Echoplexed cornet, and various processed and/or synthesized noises weave in and out of a surprisingly restrained tapestry. Recorded live-in-the-studio before an invited audience.

Mnemonists - Some Attributes of a Living System (Dys 02)
In many ways similar to "Heathen Earth", the Mnemonist also present a dense collage of guitar, speaking, trumpet, double bass and noises. Finished the same month T.G. recorded theirs; an odd case of parallel development.

Kluster - Klopffzeichen (Schwann 511)
Kluster - Zwei Osterei (Schwann 512)
Re-issues of the godfathers of the two above, recorded a decade earlier and until recently unavailable. Violin, flute, drums, crude electronics and lots of tape echo are used in bizarre epic collages, documenting the first impact of the late-60s American psychedelia on Germany.

Louis and Bebe Barron - Forbidden Plant Soundtrack (Planet 001)
The first in what may become a long line of electronic film scores. Surprisingly advanced for 1956, the Barrons present 23 short vignettes for which individual circuits had to be designed. Available only direct from Planet Records, P.O.Box 3977, Beverly Hills, CA 90212.

Carlos/Ligeti/Bartok/Penderecki - The Shining Original Soundtrack (Warner Bros. 3449)
Two tracks by Wendy; one an uncredited lift, the other an open-loop drone - both nice. The rest of the album is 'modern serious'; it sounded better in the film.

Lol Coxhill/Morgan-Fisher - Slow Music (Pipe 1)
Coxhill plays enigmatic soprano saxophone, Fisher tape-loops it. It makes for a pretty interesting combination.

THE MACHINE THAT HOLDS THE WORLD TRACK RECORD.



The Tascam Series 80-8 has become the most popular 8-track multichannel recorder in the world. Its reliability has been proven in basements, garages, and recording studios everywhere.

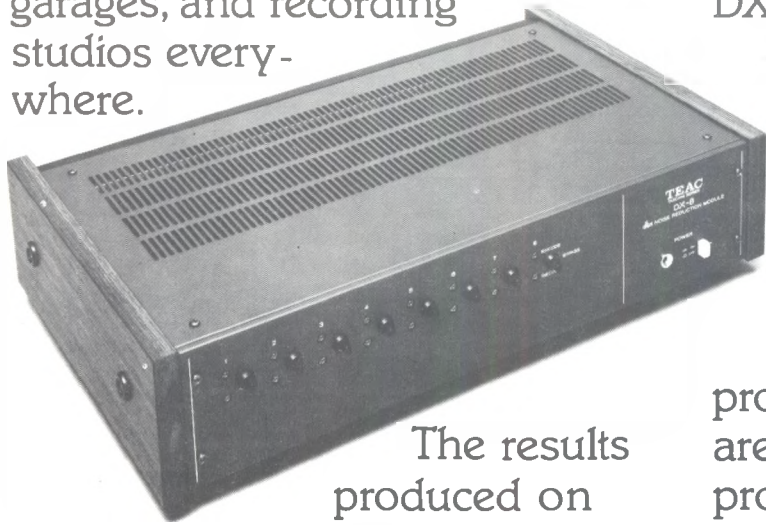

The results produced on the 80-8 are a matter of record. Sometimes gold.

The 80-8 proved a new standard was needed. Eight tracks on half-inch tape. 15 ips only. This new format allowed us to create a combined record/reproduce head, with full frequency response in the sync mode.

The 80-8 proved multichannel recorders could be relatively easy to operate. Our Function Select buttons determine the record, monitoring and dbx* status. One button for each track.

The 80-8 proved that performance and versatility could be affordable. Signal-to-noise is better than 95 dB (weighted) with our integral dbx unit (Model DX-8). Once installed, it's totally automatic. And our new Variable Speed Control** lets you adjust 15 ips $\pm 20\%$ to solve tough cueing and timing problems or add creative effects.

The 80-8 is proving that in professional recording, results are all that count. Because to us, pro means results. On demand. For payment.

If you agree, see your Tascam Series dealer for the machine that can prove it. Because it makes sense to do business with the people who have the track record.

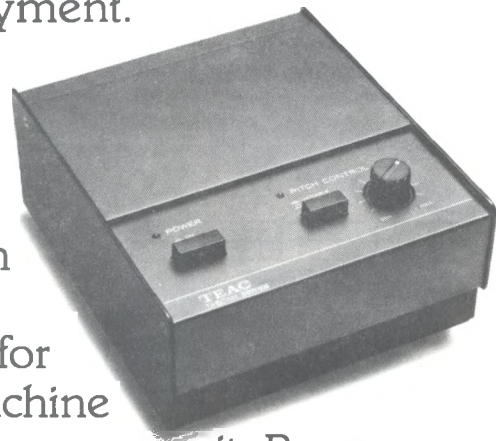

*Registered trade mark of dbx, Inc.

**Installation required; a new DC servo-controlled motor is included.

TASCAM SERIES
TEAC Professional Products

©1979 TEAC Corporation of America, 7733 Telegraph Road, Montebello, CA 90640.

EXTERNAL BATTERY SUPPLY made simple

by Paul Baltzegar

It is very simple to change the batteries in some effects boxes: simply pull out a plate, or unscrew a couple of screws, and you're ready to go. On the other hand, some effects are more difficult to open up. Trying to deal with one of the latter when a battery goes bad in the middle of a set can be exasperating.

But - who says that batteries have to be on the inside of an effect? For those who have not already invested in an adapter, or have effects with different power requirements and don't want to buy a different adapter for each one, the solution is to make external battery connectors.

For the average wa-wa pedal with a 9 Volt supply, this is a simple enough operation. Wire a battery clip to the type of mini-plug that mates with the wa-wa's AC adapter, then plug this into the AC adapter jack. In most units, the red wire connects to the tip and the black to the shaft (see figure 1); however, this is not standard for all

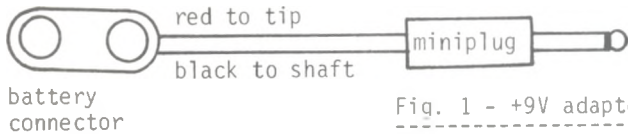

Fig. 1 - +9V adapter

products so you might want to do some checking with a VOM to see what connects to what.

With the E-H Electric Mistress Flanger, you need two batteries in order to provide 18V at 20 mA. In this case, connect the batteries in series (see figure 2).

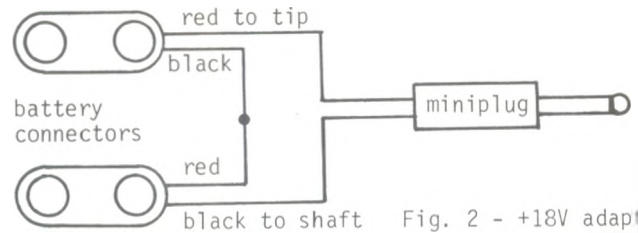

Fig. 2 - +18V adapter

Now for something a little more difficult. Craig's "Spluffer" (active splitter/dual buffer...see 11/77 issue of *Guitar Player*) requires a 9 Volt positive and a 9 Volt negative supply. I used a stereo phone plug (I couldn't find a stereo mini-plug and besides, I didn't want to get this connector mixed up with the one for the flanger since they both use two batteries). Connect the negative pole of one battery to the ring and its positive pole to the shaft (ground). Connect the positive pole of the second battery to the tip and its negative pole to ground (see figure 3). Use a

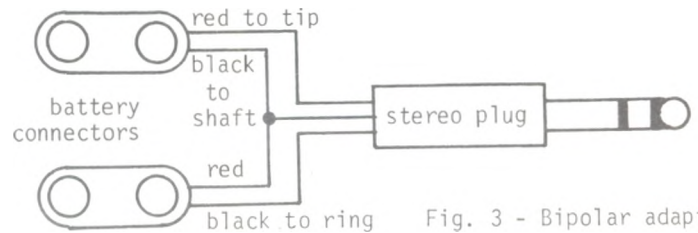
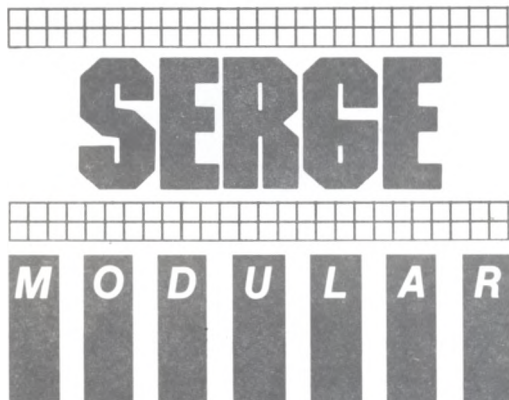

Fig. 3 - Bipolar adapter

stereo phone jack at the effect. The terminal corresponding to the tip connects to the negative supply point of the board. Wire the ground terminal to the ground terminal of the input jack.

There's one more advantage to this system: when you're finished playing, it is no trouble at all to unplug the batteries and put them in the refrigerator for extended life. Also, for all those music stores out there who are always having batteries in their effects go dead, this approach represents a good solution. Make up a couple of these "battery packs", and plug them into the AC adapter jack whenever it's time for a demonstration. After the demonstration, put the batteries away. This way you avoid having batteries left on accidentally in an effect, which could cause damage from leakage if they're left in there for too long.



Synthesizers—kits & assembled

Studio quality / Compatible / Ultra versatile / Serge Modular
 Precise / Modular / Affordable / Music Systems
 572 Haight, SF Ca 94117
 Write or call for free catalog / 415/621-6898

CURRENT EVENTS

Keyboards

NEW KEYBOARDS. In the past few months, many new keyboard instruments have been introduced. Here are some of them:

Salamander Music Systems (PO Box 40267, San Francisco, CA 94140) announces the VOICE 400 programmable lead synthesizer. A stand-alone unit that's designed to be used in conjunction with any IV/octave keyboard or equivalent P/V converter, VOICE 400 stores 32 presets and includes editing facilities. Other features include two VCOs, 24 dB/octave multi-mode filter, three envelope generators, programmable analog delay with external input, LFO, sample and hold, and compact size. The VOICE 400 lists for \$1980; a matching digital keyboard with built-in remote control lists for \$875.



Oberheim Electronics (1455 19th St., Santa Monica, CA 90404) has updated the OB-X into the OB-Xa. Added features include a split keyboard function with programmable split and balance, a doubling mode (allows for playing two sounds with one key), improved noise generator, new panel graphics, and a new modulation/bend assembly with independent sine/sawtooth LFO. Prices: four voices, \$4995; six voices, \$5595; eight voices, \$6195.



Moog Music Inc. (2500 Walden Avenue, Buffalo, NY 14225) has introduced the Opus 3, a 49 note polyphonic synthesizer that creates a wide range of string, organ, and brass voices either individually or in any desired combination. Suggested list price is \$1195.



Sequential Circuits Inc. (3051 North 1st Street, San Jose, CA 95134) has announced the Pro-One, a low cost (list price: \$645) 3 octave monophonic synthesizer. Features include circuitry based on their Prophet poly synth to give the "Prophet sound", two VCOs, 24 dB/octave LP filter with associated 4 stage envelope generator, extensive modulation capabilities, built-in digital sequencer, arpeggiator, audio input for processing traditional instruments, and an internal digital interface that facilitates hooking up the Pro-One to most home computers.

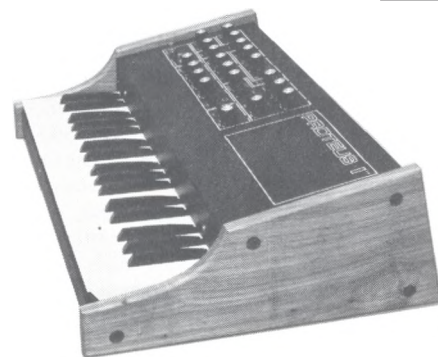

PAiA Electronics, Inc. (1020 W. Wilshire Blvd., Oklahoma City, OK 73116) has begun shipments of the PROTEUS I Programmable Preset Lead Synthesizer. The instrument is currently featured on PAiA's 24 hour Demo/Order line 405-843-7396. An evaluation package consisting of the PROTEUS I's three Assembly and Using manuals and a demo cassette is available for \$10.00 which is refundable with an order for the instrument. (PPD in USA)

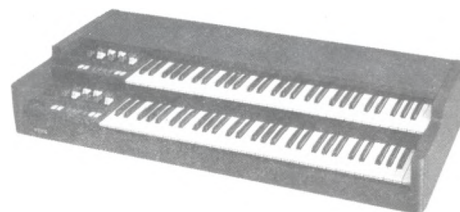

Unicord (89 Frost St., Westbury, NY 11590) now offers the Korg BX-3, a dual manual organ designed to offer "tone wheel" organ sounds as well as electronically generated rotating speaker effects. Other features include an overdrive control, separate tuning for each manual, and portability - the BX-3 weighs in at 44 pounds.

Something Else

A NON-SHOCKING ANNOUNCEMENT. Audio & Design Recording (Box 786, Bremerton, WA 98310 - telephone 206-275-5009) has announced D'ZAP!, a small (4" X 1.5") battery powered combination shock hazard detector and cord checker. D'ZAP! is claimed to detect voltage leakage and improper grounding as well as check most 2 and 3 conductor cables for phase and continuity.

STUDIO QUALITY ENVELOPE CONTROLLED FILTER. Beigel Sound Lab (24 Main Street, Warwick, NY 10990) has introduced an envelope controlled filter for studio use. Features include a choice of logarithmic or linear envelope response, external effects loop, three filter modes, and balanced/unbalanced inputs and outputs to handle a wide variety of interfacing needs.

CURRENT EVENTS

'Tell Them You Saw It In Polyphony'

ICs

NEW SSM MUSIC ICS. Here's advance information on three new products from Solid State Microtechnology (2076B Walsh Avenue, Santa Clara, CA 95050).

The SSM2033 is a precision voltage controlled oscillator IC with sawtooth, triangle, and variable width pulse outputs. Simultaneous exponential and proportional linear sweep inputs provide a 500,000:1 control range. Regulation of the chip's operating temperature makes external temperature compensation unnecessary, as well as providing excellent claimed stability. Other features include voltage controlled pulse duty cycle, single trim adjustment (for V/octave), on-chip control voltage summer, short circuit protected outputs, and hard/soft sync inputs.

The SSM2022 is a low cost dual VCA that requires very little support circuitry. Features include antilog or linear gain control characteristics, summing nodes for signal and linear control inputs, 76 dB S/N ratio, 0.2% THD, and wide supply voltage range.

The SSM2056 is a four stage (ADSR) voltage controlled transient generator that claims near zero offset and control feedthrough. Features include standard 5V peak output, exponentially controlled 50,000:1 range on all timing inputs, output short circuit protection, and gangable control outputs to allow for easy interfacing with electronic controllers and programmers.

NEW CURTIS MUSIC ICS. There are some new Curtis Electromusic Specialties (110 Highland Ave., Los Gatos, CA 95030) chips on the horizon as well as the SSM ones mentioned above; here's some information gleaned from preliminary data sheets.

The CEM3360 is a low cost, easy to apply dual VCA. Features include exceptionally low noise (-110 dB) and control voltage feedthrough, wide supply voltage range, summing node signal inputs, and differential control inputs for added flexibility.

The CEM3350 is a dual voltage controlled state variable filter.

Features include low cost, separate voltage controlled frequency and Q control inputs for each filter (15 octaves typical range, 1/2 to 100 typical Q range). A unique input/output structure allows the chip to be configured into many novel voltage controlled filters (high pass, multiple resonator, bandpass, etc.).

UNIVERSAL FREQUENCY COUNTER CHIP. Intersil (10710 N. Tantau Ave., Cupertino, CA 95014) now offers the ICM7226A, a "universal" counter chip that measures frequency (DC to 10 MHz), period (0.5 microseconds to 10 seconds with 0.1 microsecond resolution), units (up to 100,000,000 at a 10 MHz counting rate), and time intervals (up to 10 seconds with 0.1 microsecond resolution). The chip drives either common anode or common cathode displays directly, and requires very few external parts for operation. Price is under \$25 in 100s; hopefully some hobbyist parts place will start carrying these soon.

Another interesting Intersil chip is the ICL7109, which contains all active analog and digital circuitry required to convert an analog input into digital data. The byte oriented, three state output allows this chip to interface easily with 8 bit and wider microprocessor data busses; handshaking allows for direct interfacing with standard UARTs for remote serial data transmission. Price is only \$12 in hundreds.

CMOS AUDIO ATTENUATOR. Analog Devices (804 Woburn St., Wilmington, MA 01887) has introduced the AD7110, a 16 pin IC which provides 0 to 88.5 dB of attenuation (along with full muting) in 1.5 dB steps. Signal-to-noise ratio is claimed to be greater than 100 dB over the audio range, with -98 dB harmonic distortion and -92 dB intermodulation distortion. Cost is approximately \$10 in 100s.

PHONEME ORIENTED SPEECH SYNTHESIS CHIP. Votrax (Troy, MI 48084) is scheduled to introduce a phoneme oriented speech synthesis IC selling for under \$15. Unlike chips which store a limited number

of words, a phoneme oriented device stores actual sounds that make up words. Stringing these phonemes together in the right order creates virtually any word in the English language; however, the speech does not sound conversational, instead giving a "robot-speech" type of effect. Nonetheless, for instances where a large vocabulary is more important than human speech characteristics, this looks like a promising development.

NEW AUDIO IC POWER AMP. Packaged in a SIP (single in line package), the LM2878 from National Semiconductor (2900 Semiconductor Drive, Santa Clara, CA 95051) puts out up to 5 Watts at 1 KHz into an 8 Ohm load. Supply voltage ranges from 6 to 32 VDC, open loop gain is 70 dB, and distortion is typically 0.14% at 2 Watts. The LM2878 is short circuit protected, internally compensated for gains greater than 10, and includes thermal shutdown protection.

VIDEO, MEET AUDIO. Hitachi has collaborated with Victor Co. of Japan on an LSI five-chip set that simplifies the pulse-code modulation audio recording process. Designed for compatibility with standard consumer videocassette machines, this chip set is expected to bring down the cost of PCM recording adapters for video recorders.

ANOTHER "AUDIO MICROPROCESSOR" DUE IN MID-1981. Intermetall GmbH of West Germany has announced the MAA 1000, a single chip n-MOS processor for audio that samples input signals at 200 KHz. 16 bit inputs and outputs, as well as an extremely fast ALU, allow for professional quality, low distortion processing. The chip includes an on-board ROM that contains subprograms for handling specific tasks (such as delay, speech synthesis, stereo hi-fi applications, etc.).

DIGITAL POTENTIOMETER NOW AVAILABLE. Analogic (804 Woburn St., Wilmington, MA 01887) offers the AD7525, a digitally controlled potentiometer IC capable of resolving 1,999 steps. The chip features low power consumption and feedthrough.

Op Amp

JFET INPUT OP AMPS STARTING TO APPROACH BIPOLAR NOISE LEVELS. Fairchild Semiconductor (PO Box 880, Mountain View, CA 94042) has introduced its line of "Quadrafet" op amps. These claim to have noise levels below 16 nV/root Hertz, slew rates greater than 13 V/microsecond, and 50 pA input bias current. The uAF771 is a single op amp, the uAF772 a dual op amp, and the uAF774 a quad op amp.

YET ANOTHER OP AMP FAMILY. NFET is the Texas Instruments name for a new op amp family that combines N-Channel FETs and bipolar circuitry on the same chip. These single supply amps, that operate from 3V to 36V, sense signals close to or at ground with no negative supply, and have the high input impedances associated with bifet circuits. They do not, however, have particularly great noise or slew rate specs (34 nV/root Hz @ 1 KHz and 0.6V/microsecond, respectively).

Sources

NEW PARTS SOURCE. PGS Electronic Supply (PO Box 735, Terra Haute, IN 47808) is beginning to offer a variety of parts of interest to electronics hobbyists. Write for their list of available components.

ESOTERIC RECORD SOURCES. Many Polyphony readers have musical interests that extend way beyond the top 40 (to say the least!), but have a hard time locating rare or private label recordings. Aeon Import Records, Inc. (604 Princeton, Fort Collins, CO 80525 - telephone 303-484-0963) stocks a number of electronic music, live improvisation, and new instrument recordings; write them for a two page flyer. San Francisco's infamous Ralph Records is currently offering a catalog and a sampler record with music by MX80 Sound, Tuxedomoon, Snakefinger, and the Residents for \$1; send the buck along with your name and address to Almost Free, Ralph Records, 444 Grove Street, San Francisco, CA 94102.

SPACE IS THE PLACE. Gary Kirkpatrick passes along the following information for those of you who share his fascination with the space program: NASA maintains a recorded answering service that tells the latest exploits of the Voyager 1 as it works its way towards the the fringes of the solar system. Call (213) 354-7237 for the current mission status.

HEATH WILLING TO TEACH YOU A THING OR TWO. Readers are frequently asking where to learn more about basic electronics. The Heath Co., probably best known for their various kit products, also offers a number of inexpensive self-study courses on subjects from basic electronics to computer programming and microprocessors.

For a catalog listing these courses, write to The Heath Company, Benton Harbor, MI 49022.

NEW MUSIC IN U.K. The London Musician's Collective puts on a wide variety of new music events. For information contact the Collective at 42 Gloucester Avenue NW1, London, England (telephone 01 722 0456).

misc.

D/A DESIGNED FOR AUDIO USE. The MP1926A from Analogic (Audubon Road, Wakefield, MA 01880) is a 16 bit D/A converter intended for audio applications. In the small signal, zero crossover region, it provides 18 bit linearity. Cost is around \$100 in production quantities.

"AUDIO HANDBOOK" PLAYS ENCORE. National Semiconductor (2900 Semiconductor Dr., Santa Clara, CA 95051) revised and reprinted their "Audio Handbook". This volume contains many useful schematics, formulas, and tables of interest to electronic musicians, including information on how to best apply National's many audio-related integrated circuits.

MUSIC PERIPHERALS/SOFTWARE FOR THE 6502. Micro Technology Unlimited (2806 Hillsborough St., PO Box 12106, Raleigh, NC 27605) offers a variety of products for machines using the 6502 processor - including music peripherals and software. For more information, request their catalog.

MAC 81 Electronic Midwest Acoustics Conference

Sat
legato *Pa.*
cresc.

of Musical Sounds

**Saturday
April 25, 1981
Hermann Hall
Illinois
Institute of
Technology
Chicago, Illinois**

- * Characteristics of Musical Sounds
- * History of Electronic Modification
- * Time Domain Modification
- * Frequency Domain Modification
- * Non-Linear Modification
- * Synthesizers
- * Future Trends

Pulse Width Multiplier

by C. Anderton

This construction project turns a static triangle waveform into a highly animated variation of a pulse waveform. Although it's difficult to describe the resulting sound in print, by describing the circuit you will probably be able to imagine the sound in your mind.

ABOUT THE CIRCUIT. The PW Multiplier uses four comparators, three of which have voltage controllable thresholds, to turn a triangle wave into a number of pulse waves with varying duty cycles. These pulse waves are then mixed together digitally via EX-OR gates, resulting in a very complex composite waveform.

Comparator IC1A converts the triangle wave into a pulse wave; trimpot R5 allows for duty cycle adjustment. Comparators IC1B-D are standard voltage controlled pulse width modulation circuits, whose thresholds are fed from three control summers (IC2A-C). So far, this would be just another pulse width modulation circuit if it weren't for the fact that the outputs of the four comparators are mixed by the EX-OR gates in an interesting way. The output of IC3A (output 1) gives a standard pulse wave output. However, IC3B (output 2) mixes this waveform along with the pulse wave coming out of IC1B. As the control voltages presented to IC2A vary, output 2 varies from a pulse waveform with the same period as the input to a pulse wave that has two pulses per period. When there are two pulses per period, the resulting sound has a strong "octave higher" component; so, varying the associated control voltage smoothly alters the harmonic content from the standard PWM variations to a totally different harmonic structure caused by the addition of the extra pulse in each period.

Mixing output 2 with the output of the comparator IC1C gives anywhere from one, to two, to three pulses per period at the output of IC3C, depending on the control voltages present at CV summers IC2A and IC2B. Similarly, mixing IC3C's output along with the output from comparator IC1D into IC3D gives anywhere from one, to two, to three, to four pulses per period at the output of IC3D, depending upon the voltages present at CV summers IC2A-C. As these control voltages vary, the harmonic structure of the waveform undergoes radical alterations. Interestingly, the sound is very "plucked string" in nature (if you look at a guitar string, you'll note that the harmonic structure is constantly changing and that the waveform is anything but static).

CONSTRUCTION. I used 4136 op amps for IC1 and IC2, although you could just as easily use 741s, 4558s, or general purpose compensated op amps. The circuit is actually quite non-critical, as long as you make sure that you feed the proper op amp inputs. IC3 can be a 4030 or 4070 CMOS EX-OR gate. IC2A-C are control voltage summers that you've probably seen before in dozens of circuits; I would suggest connecting an "initial PW" control to one input of each summer.

CALIBRATION. The PW Multiplier accepts a number of different audio input levels and control voltages,

but Ra and Rb must be chosen for a given application according to the following chart:

AUDIO LEVEL (PK-PK)	CONTROL VOLTAGE RANGE	Ra	Rb
0.5V	0 to +5V	500k	680k
5V	0 to +5V	50k	68k
10V	0 to +10V	50k	68k
20V	0 to +10V	50k	33k

Next, Ra and R6 must be calibrated so that the peak-to-peak value of the audio signal at the output of IC2D is the inverse of the control voltage range. For example, if your synthesizer uses 0 to +10V control voltages, then Ra is adjusted to give a 10V pk-pk signal, and R6 offsets the signal so that the top peak of the signal hits 0V, and the bottom peak of the signal hits -10V. With synthesizers using 0 to +5V control voltages, then Ra is adjusted to give a 5V pk-pk signal, and R6 offsets the signal so that the top peak of the signal hits 0V, and the bottom peak of the signal hits -5V. This calibration insures that the control voltage summers will affect the signal in the desired manner.

The only other calibration is to adjust R5 so that the output of IC1A is a square wave. Actually, this is not critical, and you can just as easily have pulse waves coming out of IC1A; but square waves seem to mix well with the other pulse outputs.

Now, hook up your control voltages to IC2A-C. A couple of LFO outputs, combined with an envelope generator output, work well... as do many other combinations. To get a feel for the module, you might also wish to simply connect up some pots to the inputs of the CV summers and see how changing the control voltages alters the overall sound.

CONCLUSION. The Pulse Width Multiplier represents a balance between the old (pulse width modulation) and the new (digital mixing to create interesting harmonic patterns). The circuit is very inexpensive to build, so if you're looking for something a little more interesting out of your VCOs than the standard static waveforms, give this module a try: I think you'll be as pleasantly surprised with the sound as I was. *f*

PARTS LIST

Resistors (5% preferred, 1/4 Watt)

R1,R2	10 Ohms
R3	33k
R4	47k
R5,R6	50k trimpots
R7 - R28	100k
R29,R30	220k

Capacitors (15 or more working Volts)

C1	.22uF
C2 - C4	10 uF, electrolytic or tantalum

Semiconductors

D1 - D4	1N4001 or equivalent diode (1N914 etc. also OK)
IC1,IC2	4136 quad op amp or equivalent (see text)
IC3	4030 or 4070 CMOS quad EX-OR gate

Misc. Circuit board, wire, socket, etc.

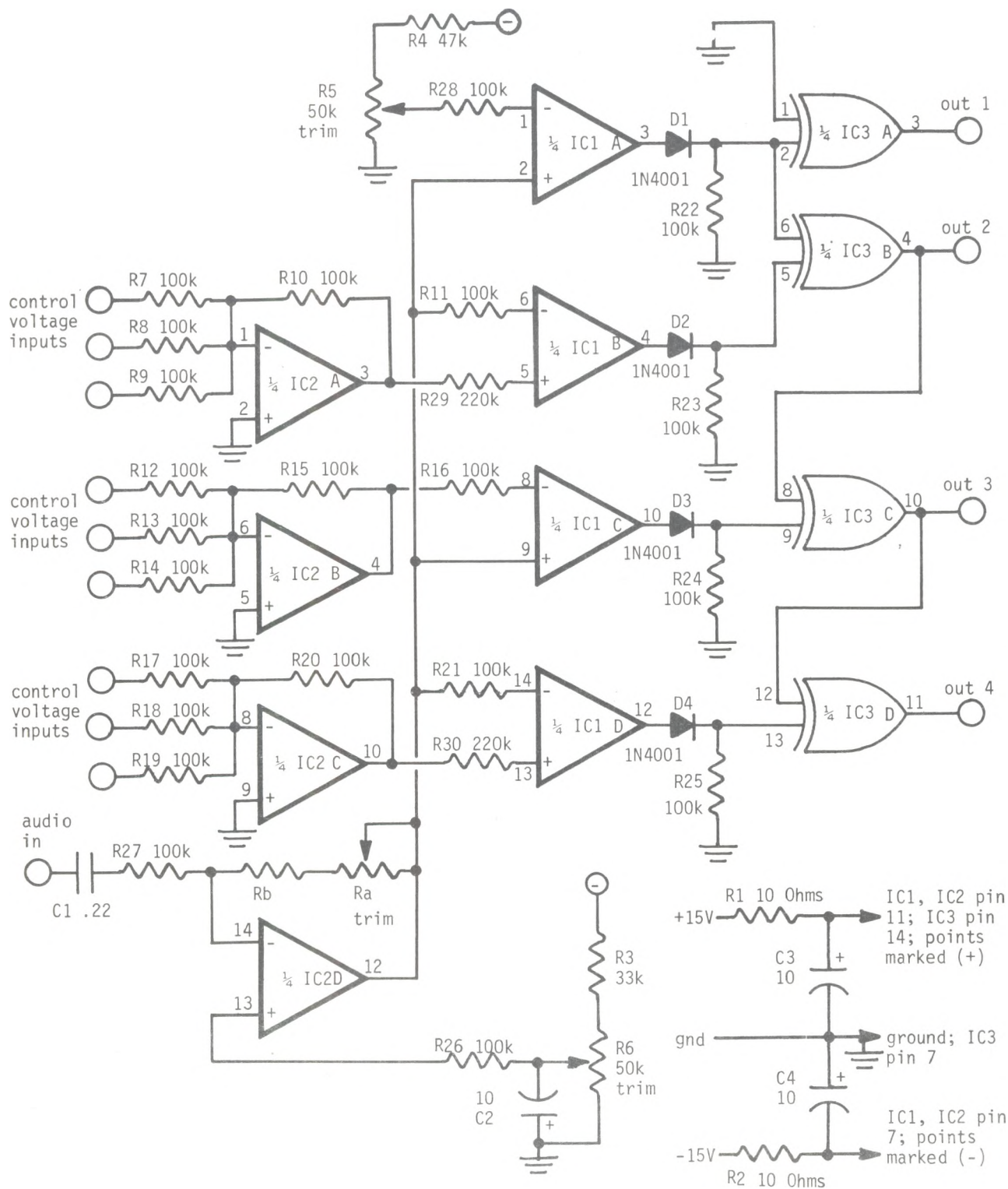

schematic
PWM

PATCHES:

For the KORG MS-10 from

Paul J. Drongowski
Salt Lake City, Utah 84102

Lead guitar

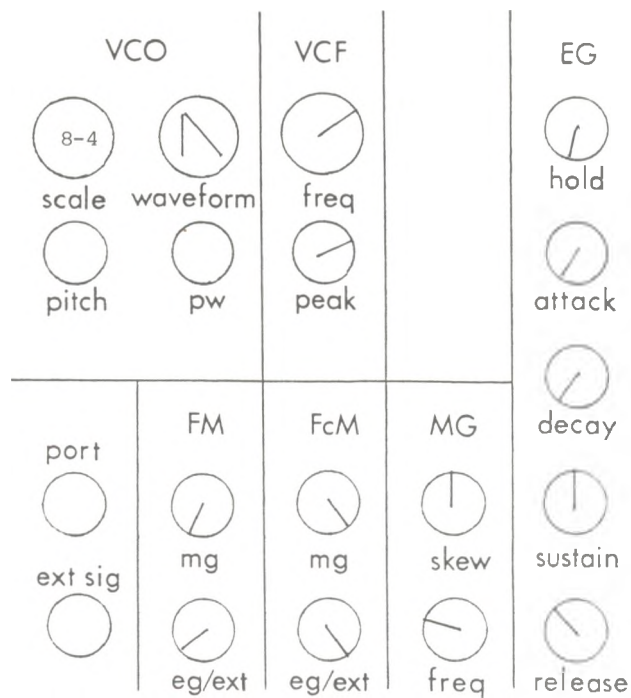

Lead guitar

- [1] Lead guitar sound from the Mandre M3000 album.
- [2] Patch wheel output to VCO frequency input for pitch bends.
- [3] Add or remove VCF modulation to taste.
- [4] A little bit of portamento will cause the notes to slide.

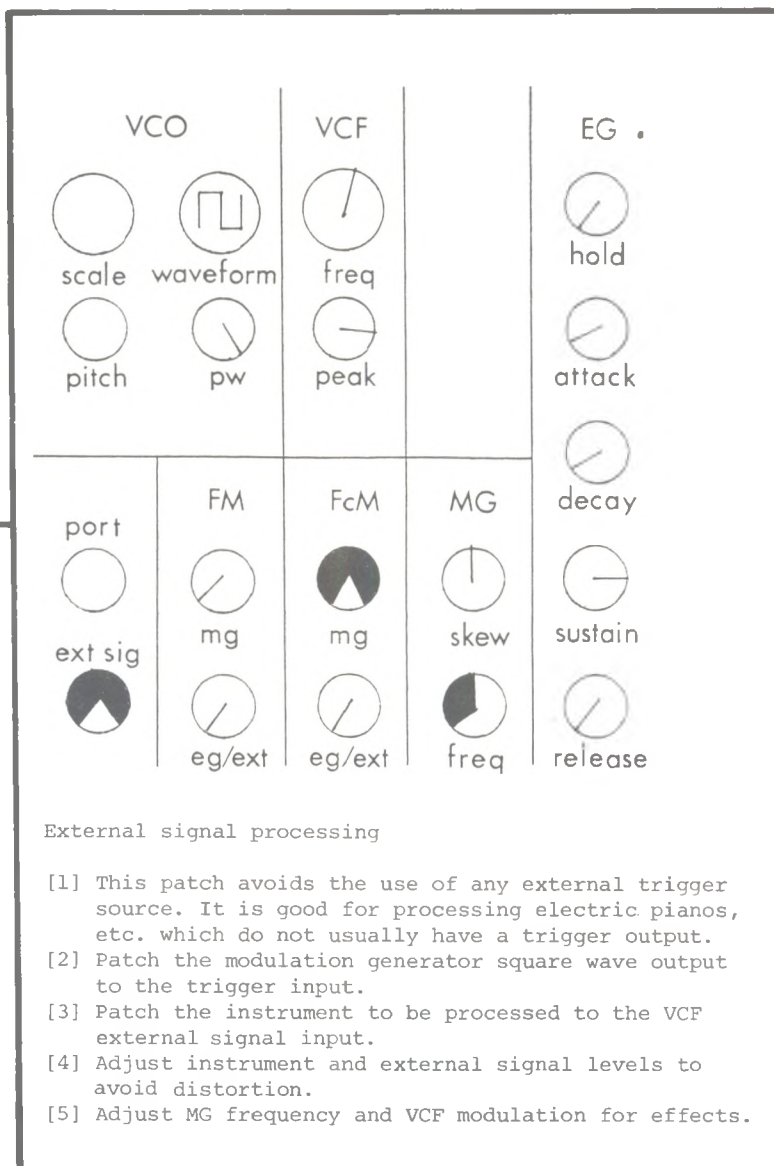

External signal processing

- [1] This patch avoids the use of any external trigger source. It is good for processing electric pianos, etc. which do not usually have a trigger output.
- [2] Patch the modulation generator square wave output to the trigger input.
- [3] Patch the instrument to be processed to the VCF external signal input.
- [4] Adjust instrument and external signal levels to avoid distortion.
- [5] Adjust MG frequency and VCF modulation for effects.

Percussive bass

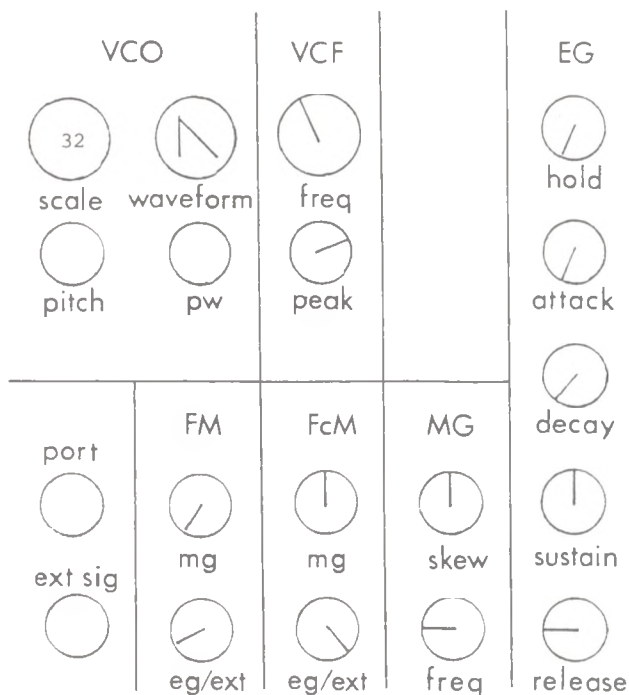

Percussive bass

- [1] Sounds like synthesized bass on Zappa's Zoots Allure album.
- [2] Patch wheel output to VCO frequency input for pitch bends.
- [3] Add or remove VCF modulation to taste.

the CAT srm synthesizer

by **OCTAVE** Electronics Inc.

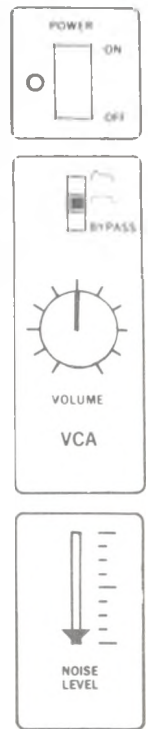
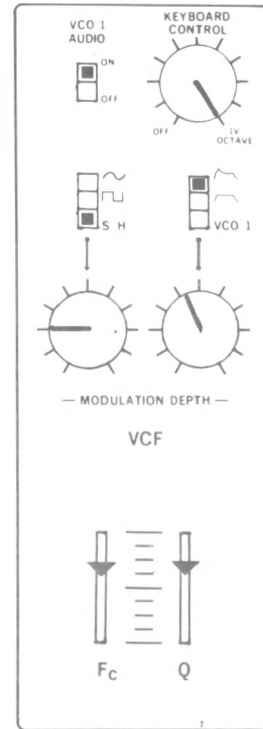
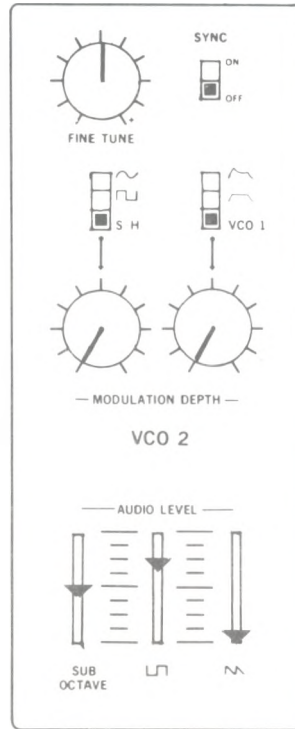
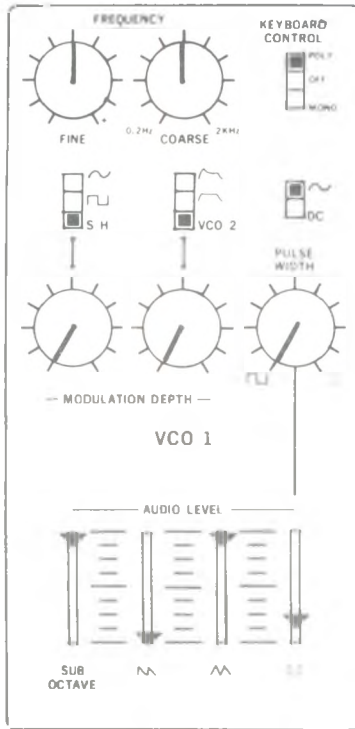
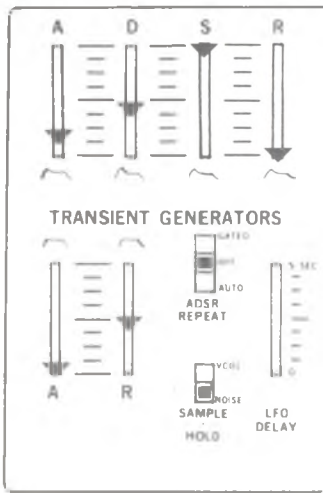

ELECTRONIC HARPSICHORD
SOUND

NOTE: USE FLANGER WITH MED. SPEED RATE
USE MED. TO FULL REVERB

Gordon McAlister
Ridgewood, N.J.

CHOIR 1.0

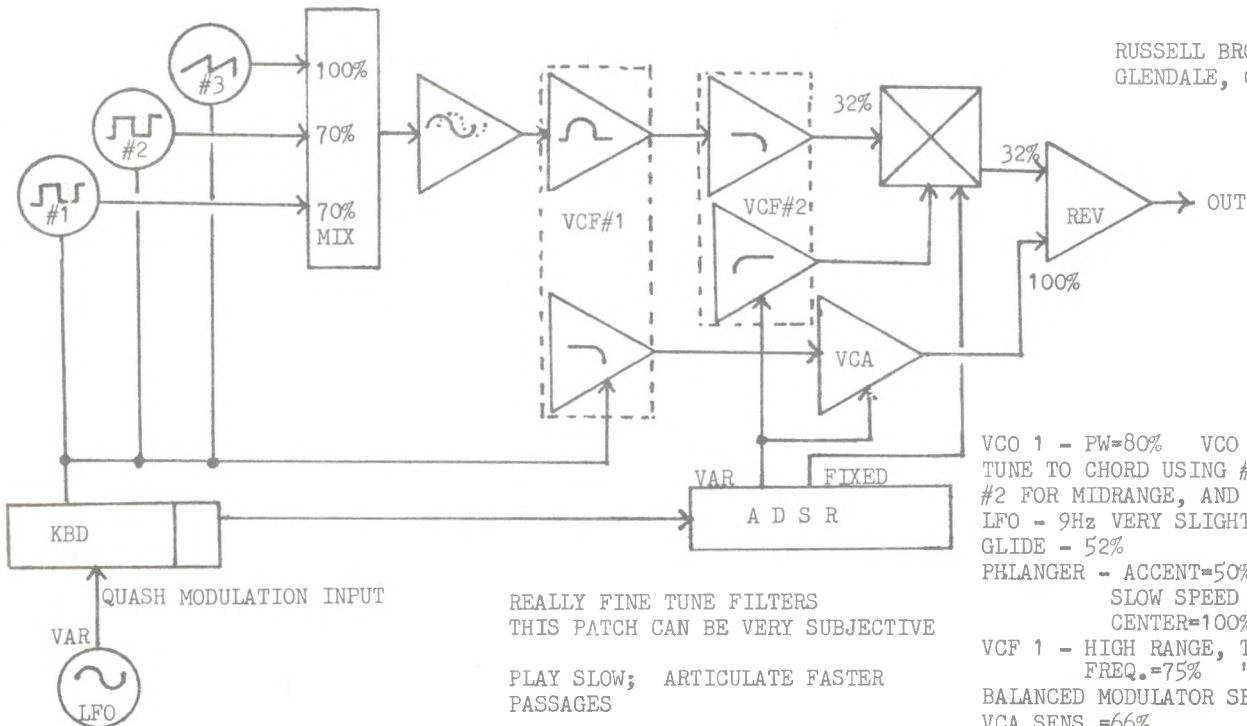

RUSSELL BROWER
GLENDALE, CALIFORNIA

REALLY FINE TUNE FILTERS
THIS PATCH CAN BE VERY SUBJECTIVE

PLAY SLOW; ARTICULATE FASTER
PASSAGES

ORGASMATRONIC GLIDE IS A GOOD
KEYBOARD PROGRAM DUE TO VIBRATO
FROM HITTING ADJACENT KEYS

VCO 1 - PW=80% VCO 2 - PW=34%
TUNE TO CHORD USING #1 FOR LOW,
#2 FOR MIDRANGE, AND #3 FOR FEMALE
LFO - 9Hz VERY SLIGHT LEVEL
GLIDE - 52%
PHLANGER - ACCENT=50% MIX EQUALLY
SLOW SPEED SPAN=53%
CENTER=100%
VCF 1 - HIGH RANGE, TRACK MODE,
FREQ.=75% "Q"=100%
BALANCED MODULATOR SENS.= 4%
VCA SENS.=66%
ADSR A=30% D=0% S=100% R=51%
REVERB MIX =50%

More PATCHES on page 17 and 31

AUDIO CIRCUIT BREAKER

by Doug Montcrieff

(Doug sends the following information about himself: "I've never written before but with your help, I think I can share some ideas with fellow readers. I'm a guitar/keyboard player with mostly music training and no electronics training. A couple of years ago an amp didn't work right, so I took it to the best shop in town and ended up paying \$30 just to have the power tubes changed! My Scottish blood couldn't deal with

Here's something that saved my band lots of money by saving speakers. Picture this: Your band is cooking along, and everything is great...until someone trips over the AC power cord. Upon discovering this error, the well-meaning person jams the plug back into the wall. KABOOM! When the power comes back to the board, it sends a tremendous spike to the power amps. After a couple of accidents

Should the AC power go off for any reason, relays interrupt the signals going from the board to the system's power amps. When power comes back on again, the audio signals remain interrupted until an additional reset button is pressed (hopefully after the power surge!).

HOW IT WORKS. The schematic shows a version using 4 relays to protect a triamped system (triamp

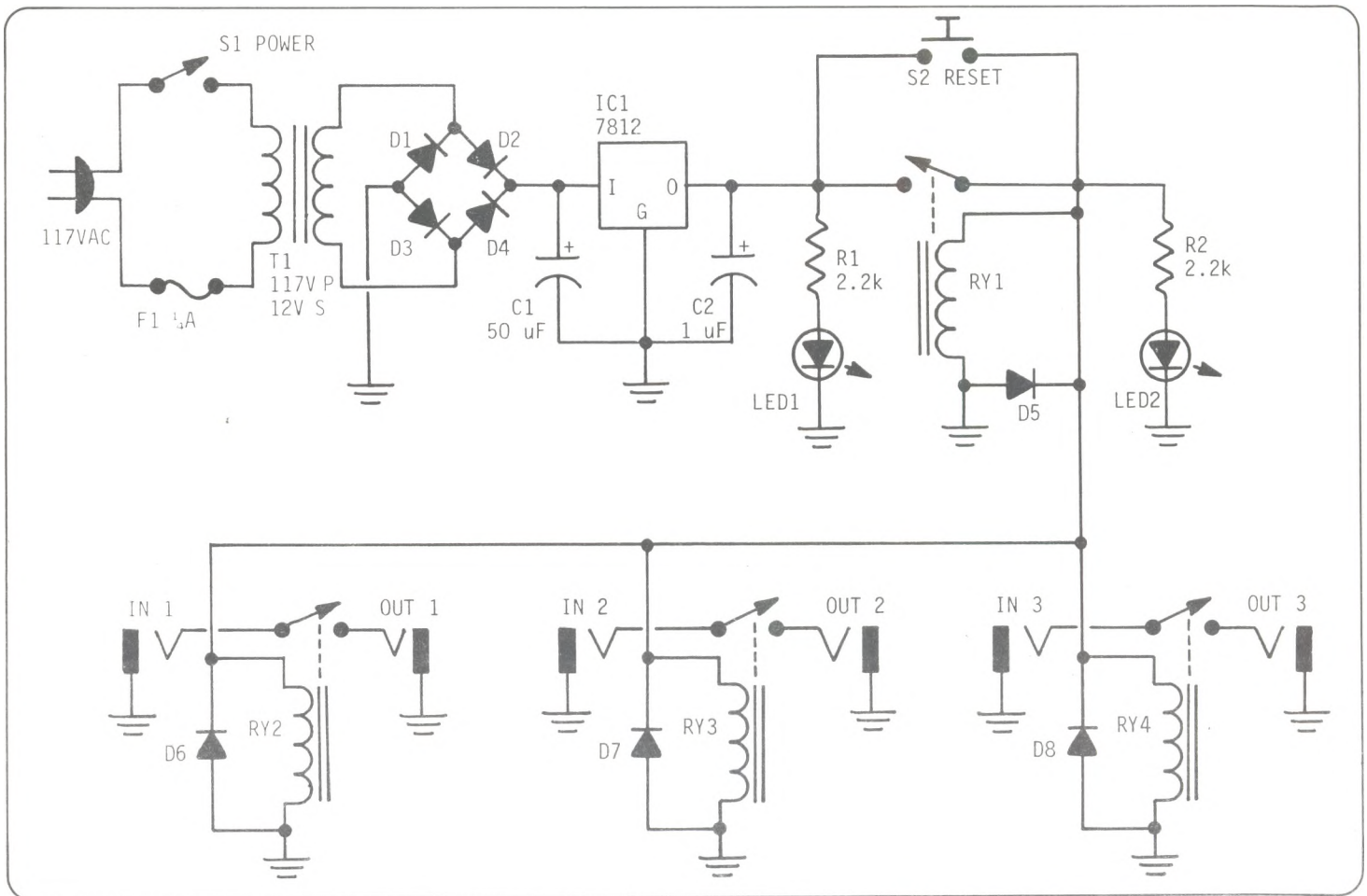

that so I started reading everything I could get my hands on about electronics (Craig's books and articles in Guitar Player and Modern Recording included). I'm currently enrolled in the Do-It-Yourself School of Electronics. My experimenting centers around troubleshooting audio problems on the road and generally making rock and roll shows easier to take."

like this, you can either convert your damaged equipment into boat anchors, or prevent such problems in the future with the audio circuit breaker (ACB for short). While I borrowed the idea from home stereo speaker protection circuits, it works fine with PA and other musical applications.

The ACB plugs into the same power box used by your board;

systems have separate high, low, and midrange power amplifiers), and inserts in the system between the crossover and power amps. T1 steps down the AC power to 12 VDC. This is rectified by D1-D4, and filtered by C1. Do not use a larger filter capacitor, since larger caps will hold the relays on for a certain amount of time after the power goes off, and the (continued.....on page 20)

PATCH:

CHRIS MEYER
Hamilton, OH

VCO 1 - ANY WAVEFORM (CHOOSE FOR VARYING HARMONIC CONTENT)
VCO 2 - SCHMITT TRIGGER IN FEED BACK LOOP OR FILTERED SQUAREWAVE
LFO - 3Hz 5V OUTPUT
BALANCED MODULATOR - SENSITIVITY SET TO WHERE OVERLOAD LIGHT JUST FLICKERS
ADSR - A - 0% D - 20% S - 25% R - 100%
VCF - LO RANGE INIT 60% Q - 50%

USE VARIABLE OUT TO CONTROL "DISTANCE"

BIAS - SET SO FILTER JUST SHUTS DOWN AS ENVELOPE FINISHES (see text)

BOTH OSCILLATORS SHOULD BE SET TO LOWER LIMIT OF AUDIBLE, VCO 1 BEING SLIGHTLY HIGHER. TUNE FOR IRREGULAR BEATS. SET BIAS FOR SMOOTHEST "RELEASE", MAY BE USED FOR AN EXPRESSION CONTROL. DIFFERENT WAVEFORM FOR VCO 1 YIELD SLIGHTLY DIFFERENT CHARACTERISTICS (i.e.- sine wave, earth; square wave, concrete and rock). WOOFERS BEWARE!

THUNDER / DISTANT EXPLOSION

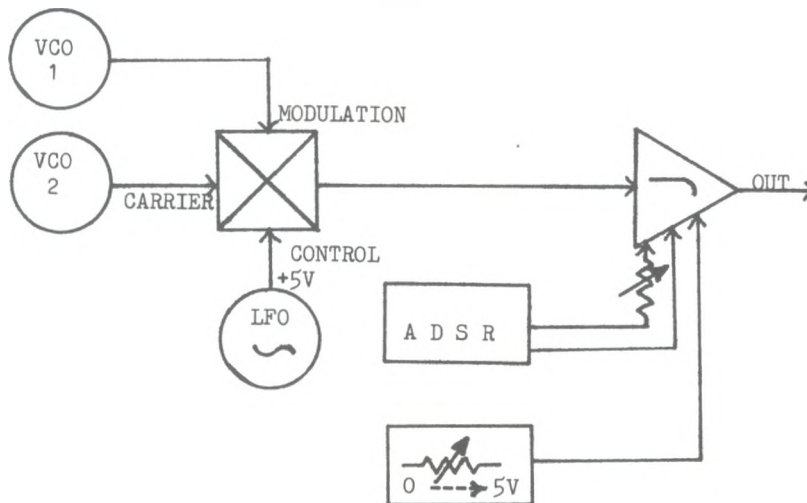

NEW

POLYMART



A logbook is one of the most useful and frequently overlooked accessories any studio can have. Without it, remix and overdubs often mean going back to re-familiarize yourself with the piece, not to mention the convenience of having all the important information on your tape library in one place as opposed to take sheets scattered among a lot of different reels. Most importantly, a well-kept logbook becomes part of your records for tax, accounting and planning purposes.

This 4/8 Track Studio Logbook represents an improvement over standard track sheets in that you can not only indicate technical information such as timing and type of tape used; there is also a generous amount of space for recording patches and making notes, as well as an expanded track sheet page that provides space for listing sequential changes in various tape tracks and relating these to settings of the index counter.

Order # SLB\$4.95

POLYMART

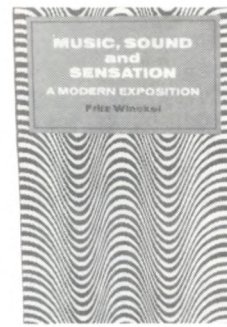
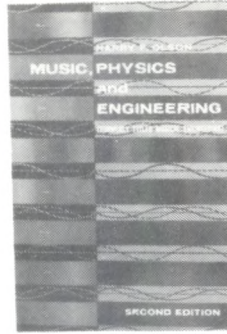
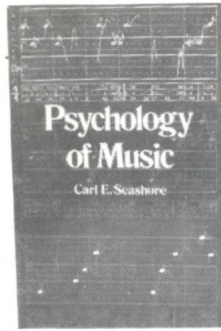

The physical and psych Helmholtz's **Sensatio** physiological acoustics Test, provides an in-d instruments. **Music, I** synthesizer, is a thorc instruments (plus a cha like the Helmholtz work

#SENS On The Sensa
#MPE Music, Physics,

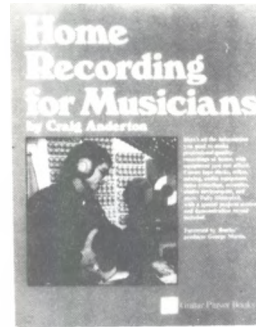
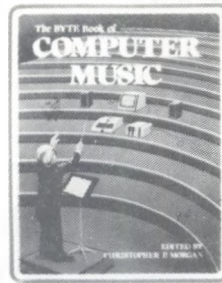
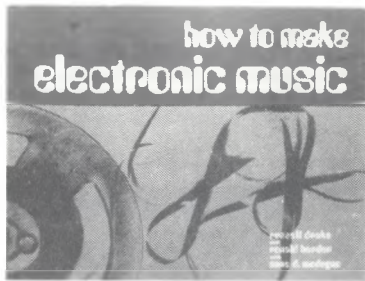
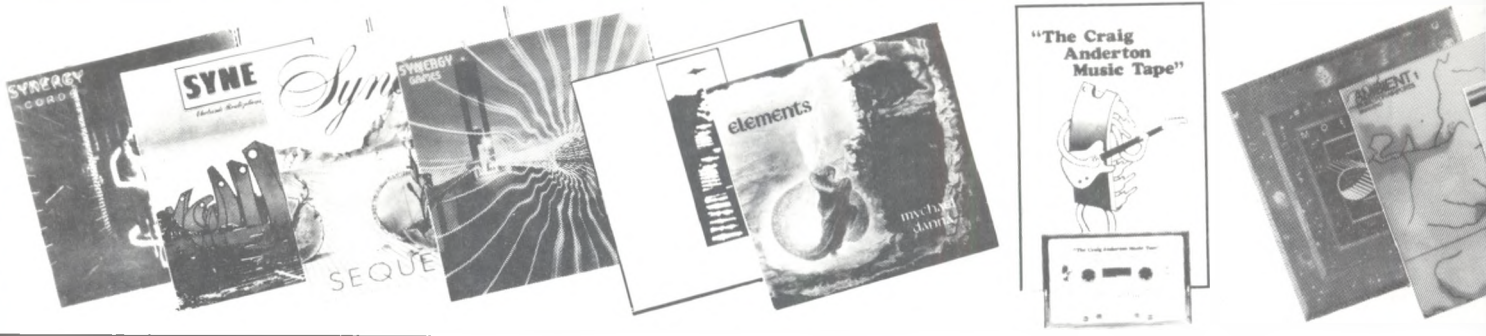

Synthesists must be ve books are a great way to and Modugno is a stand: tape technique, composi building, outfitting, and computer control of ele

#HMEM How to Make
#BYTE Byte Book of Co

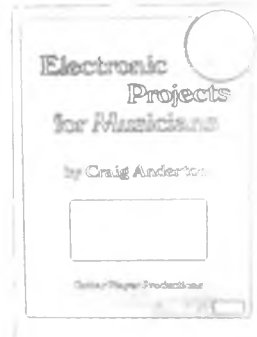
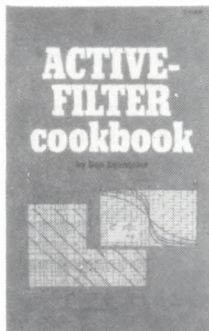
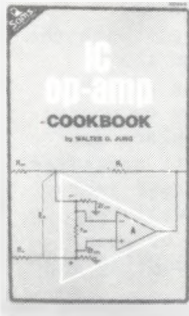

Electronic cookbooks ar theory, definitions, and er can easily replace stack reference. Walt Jung's required reading for syn applications. Lancaster's octave generators, touc electronic construction recording of the effects

#OACB Op-Amp Cookb
#AFCB Active Filter Co
#AUOA Audio Op-Amp

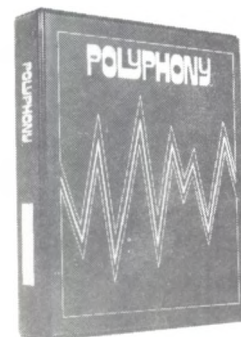
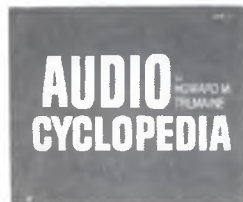
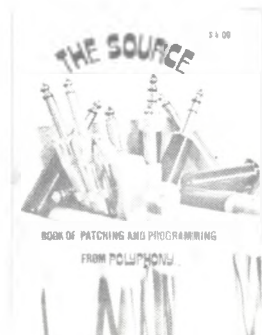

Often used reference m **The Source** is over 125 type **Audio Cyclopedic** to answer any questions publication without purc **Synthesizers** devotes Paia, Oberheim, EML, i experimenter.

#SOURCE The Sc
#CYCLO Audio t
#EMS Music
#BIND Binders

SCIENCE

...ho-acoustical background to music is an important part of musical synthesis. **Psychology of Music** is, a century after its publication, still the standard text for synthesis. **Psychology of Music** by Carl Seashore, developer of the Seashore Music Test, is a depth analysis of musical style and performance characteristics of many styles. **Physics, and Engineering** by Harry Olson, who worked on the first RCA stereo system, is a thorough discussion of the physical properties and design of traditional musical instruments (a chapter on electronic music). **Music, Sound and Sensation** by Winckel is much more detailed, with a bit less detail and more concentration on psycho-acoustics.

Psychology of Music	\$7.50	#PSYCH Psychology of Music	\$5.00
Physics and Engineering	\$5.00	#MSS Music, Sound and Sensation	\$3.50

RECORDINGS

#ERRO	Electronic Realizations - Synergy	\$7.95
#SEQU	Sequencer - Synergy	\$7.95
#CORDS	Cords - Synergy	\$7.95
#GAMES	Games - Synergy	\$7.95
#PICT	Moving Pictures - Michael Gilbert	\$7.95
#ELEM	Elements - Mychael Danna	\$6.95
#CAMT	Craig Anderton Music Tape	\$5.95
#MOEB	Moebius - Moebius	\$7.95
#ARPT	Music For Airports - Brian Eno	\$7.95
#DELTA	Rainbow Delta - Pat Gleeson	\$7.95

TECHNIQUE

...all versed in a number of techniques and principles. "How to" and project oriented books to pick up these skills easily. **How to Make Electronic Music** by Drake, Herder and Clark is an introductory text for music synthesis classes, with chapters on equipment, synthesis projects, and more. **Multitrack Primer** by Teac is a step-by-step guide to operating your home studio. The Byte book of **Computer Music** describes micro-mechanical instruments, Fourier analysis, circuits and loads of software. **Home Recording for Musicians** is the original guide to outfitting and operating a budget studio for home recording, including mixer and audio processing circuits and a demo recording.

Electronic Music	\$3.95	#TEAC Multi-Track Primer	\$4.95
Computer Music	\$10.00	#HRFM Home Recording	\$9.95

ELECTRONICS

...are a great way to stock your library with materials that are not only heavy on educational material, but chock full of practical applications as well! These books consist of manufacturers data sheets and applications notes all in an easy to use format. **Op-Amp** and Don Lancaster's **Active Filter** books are self-explanatory -- essential for synthesists! **Audio Op-Amp** is an edited version of OACB, containing only audio projects. **CMOS** book is much more than a digital reference -- phase lock loops, topologies, and other things you need! **Electronic Projects** discusses synthesis techniques for the novice and provides 19 projects with PC patterns and a demo tape.

CMOS Cookbook	\$14.95	#CMCB CMOS Cookbook	\$10.50
Electronic Projects	\$14.95	#EPFM Electronic Projects	\$7.95
Applications	\$7.95		

REFERENCE

...materials to answer the many questions encountered in everyday synthesis(?) ... This book has 500 pages of patches in universal flow chart notation; the largest publication of its kind has 1760 pages with 3650 entries and hundreds of drawings and schematics about audio. **Polyphony Binders** hold up to 12 issues of any 8 1/2" x 11" binder; punch holes; keeps issues like new for unending service. **Electronic Music** is the first half of features and functions of commercial equipment (Moog, Arp, and RMI); the second section provides schematics and projects for the

Source	\$4.00
Cyclopedia	\$39.95
Synthesizers	\$4.95
	\$5.95

POLYMART is provided to help Polyphony readers find the special supplies their projects require. The items we stock are a **must** for every active music experimenter's lab or studio bookshelf. Not all of PolyMart's offerings are shown in each issue. Refer to back issues if you don't see what you want. Your suggestions for additional items are welcomed.

TO ORDER: Tear out this half page order blank; note that there is a back issue list on the other side. We cannot invoice; payment must be enclosed with your order. To help defray shipping and packaging costs, there is a flat \$5.00 handling fee per order plus payment of postage costs. MasterCharge and Visa are welcome, but there is a \$10.00 minimum on charge orders. Foreign orders **must** be paid by certified check or money order in U.S. \$ drawn on a U.S. bank (or by charge card). Phone orders are welcomed for charge card orders only.

Name: _____

Address: _____

City _____ State _____ Zip _____

Card # _____

MasterCharge Bank # _____ Expiration Date _____

Signature _____

Quantity _____ Item _____ Price _____

_____	_____	_____
_____	_____	_____
_____	_____	_____
_____	_____	_____
_____	_____	_____
_____	_____	_____
_____	_____	_____
_____	_____	_____
_____	_____	_____
_____	_____	_____

_____ # of items _____ Sub Total _____

Shipping Charges _____ Handling _____ 50

U.S.: add 10% of SubTotal or \$5.00 maximum

Foreign: 20% of SubTotal or \$10.00 maximum

Shipping _____

SUBSCRIPTION

U.S. \$12/YR. \$22/2 YRS.
FOREIGN \$14/YR. \$26/YR.

SUBSCRIPTION _____

Back Issues (from other side) _____

Total Enclosed _____

Return This Half Page

To: **POLYMART**
P.O. Box 20305
Oklahoma City, OK 73156



Back Issues

The wide variety of practical applications and construction projects in past issues make a binder full of Polyphonys a frequently used reference to keep near your synthesizer, home studio, or workbench. Most back issues are still available for \$2.00 each ppd. Check the issues desired on this coupon and add the total to your PolyMart order (other side), or order by volume and issue number (0304, 0402, etc.) on the PolyMart form.

#0101: 1975: SOLD OUT

#0201: 1/76: SOLD OUT

#0202: 2/76: SOLD OUT

#0203: 3/76: SOLD OUT

#0204: 4/76: music notation - timing, external inputs for Gnome, Programmable Drums, Equally Tempered D/A, low cost AR project, digitally encoding keyboards, patches, Volume 1 & 2 index.

#0301: 7/77: frequency divider project, random tone generator project, normalizing synthesizer controls, eliminating patch cords, computer control of analog modules, Chord Egg modification, adding pitch bending, patches.

#0302: 11/77: The Sensuous Envelope Follower, digital gates, LED wall art, build a bionic sax, data to music peripheral project, Apple II as a music controller, using the NE566 as a VCO, patches.

#0303: 2/78: computer controlled Gnome, using joysticks, build a bionic trumpet, ultra-VCO modifications, voltage control the Mu-Tron Bi-Phase, oral joystick, patches.

#0304: April/May 78: Minimoog modifications, non-keyboard module use, phasing and flanging (theory and circuits), memory expansion for programmable drums, digitally addressed transposer project, polyphonic software (with software transient generators), patches, Volume 3 index.

#0401: July/August 78: analog delay lines (theory and projects), composing for electronic music, note to frequency (and visa versa) conversions, build a trigger delay, software for computer composition, low cost VCO circuit, patches.

#0402: Sept/Oct 78: electronic music notation, notes on the recording of "Cords" by Larry Fast, sequencer software - part one, rhythmic control of analog sequencers, touch switch projects, modular vocoder techniques, PET as a music controller, patches.

#0403: November/December 78: SOLD OUT

#0404: January/March 79: add-ons for vocal F and V converter, shorthand patch notation, more on note to frequency conversion, graphic monitor project, George Russell, super VCA circuit, echo software, Vol. 4 index.

#0501: May/June 79: SOLD OUT

#0502: July/August 79: hex VCA/mixer project, electronic music schools and studios, modify the Oberheim Expander Module, profile of Ernest Garthwaite, budget microphones, digitizer projects and software, bar graph ICs.

#0503: September/October 79: SOLD OUT

#0504: November/December 79: SOLD OUT

#0505: January/February 80: Joseph Byrd, Mort Garson, Larry Fast on 'Games', composing for 'live tape', using the CA3280, recording vocals, ADSR circuits.

#0506: March/April 80: SOLD OUT

#0601: May/June 80: SOLD OUT

#0602: July/August 80: Peter Gabriel, digital VCO project, dream modules, optimum level settings, dynamic phrasing, patches.

#0603: Sept/Oct combined with Nov/Dec 80: alternate controllers, add voices to Casio M-10, voltage controlled quadrature oscillator project, cordless patch bay, recording rules, patches.

(continued.....from page 16)

relays should open up at the first sign of power loss.

IC1 regulates the unfiltered voltage down to a regulated 12V, with LED1 and current limiting resistor R1 indicating that power is reaching the unit. As soon as the reset button is pressed, RY1's coil receives power and its contacts close. This provides power to RY2 - RY4, and closes these contacts. Each set of contacts interrupts the crossover outputs going to the power amps, providing the audio circuit breaker function. Diodes D5 - D8 clamp the spikes released from the relay coils when power is cut.

If you have a mono system or do not use a crossover, eliminate RY3/RY4, D7/D8, and the corresponding jacks to create a single channel version.

MODIFICATIONS. This is a very non-critical circuit, so many substitutions are possible. If you don't have 12V DC relays, you can use 6V types by changing T1 to a 6V transformer and IC1 to a 6V regulator. 5V reed relays designed for computer logic applications will also work; again, use 6V transformer but change IC1 to a +5V regulator. In both cases, R1 and R2 should be 1K instead of 2.2K.

The ACB has served my band well, and hopefully it will do the same for you. *f*

AUDIO CIRCUIT BREAKER PARTS LIST

T1	117V AC primary, 12V AC secondary, 500 mA or more (see text)
C1	50 uF electrolytic capacitor, 25 Volts DC
C2	1 uF electrolytic or tantalum capacitor, 15 Volts DC
D1-D8	1N4001, 1N4002 or equivalent power diodes
IC1	7812 or equivalent +12V regulator (see text)
LED1, LED2	red LED
R1, R2	2.2K resistor (see text)
RY1-RY4	SPST relays with 12V DC coils, contact ratings not critical
F1	Fuse (1/4A)
S1	SPST on-off switch
S2	SPST reset momentary pushbutton switch
Misc.	Jacks, box, wire, solder, etc.

Build a Quad Sequential Switch by Tim Fluharty

Electronic switches have great potential for control elements, once you create support circuitry that can control them in sophisticated ways. This module, designed for compatibility with PAiA equipment, closes four electronic switches sequentially in response to trigger inputs. This may not sound too earth-shattering, but read on - there are many uses for this deceptively simple module.

ABOUT THE CIRCUIT. The heart of this circuit is a 4017 CMOS decade counter (see figure 1a for pinout), which is an extremely useful chip for electronic music applications. At any given time, only one of its ten outputs (numbered 0 - 9) is in a logical 1, or "high", state. Sending clock pulses to the trigger input steps this logical 1 through each stage, one stage at a time. Referring to figure 1b, the first trigger makes output 0 go high (all other outputs are low). The next trigger turns on output 1, the next trigger turns on output 2, and so on until output 9. At that point, the sequence starts all over again.

again. Returning different outputs allows for counting different numbers of events.

DESIGN NOTES. Referring to figure 2, IC2 and IC3 are CMOS parts running off a split (bipolar) supply. Since CMOS parts can't accept more than a 15V supply, zener diodes D1 and D2, along with resistors R1 and R2, drop the + 9V supply to + 6V. IC1 is a 748 or equivalent op amp, configured as a Schmitt trigger. This converts standard 0 to +5V triggers to the + 5V level required by IC2's trigger input.

IC2 is turned into a 4 stage counter by connecting pin 10 (output 4) back to the RESET input. Each of the four counter outputs drives one 4066 electronic switch control input (IC3 contains four such switches), as well as four LED drivers that show which switch is closed at any given moment.

CONSTRUCTION. The quad switch is just the right size for a double-width module. This is a

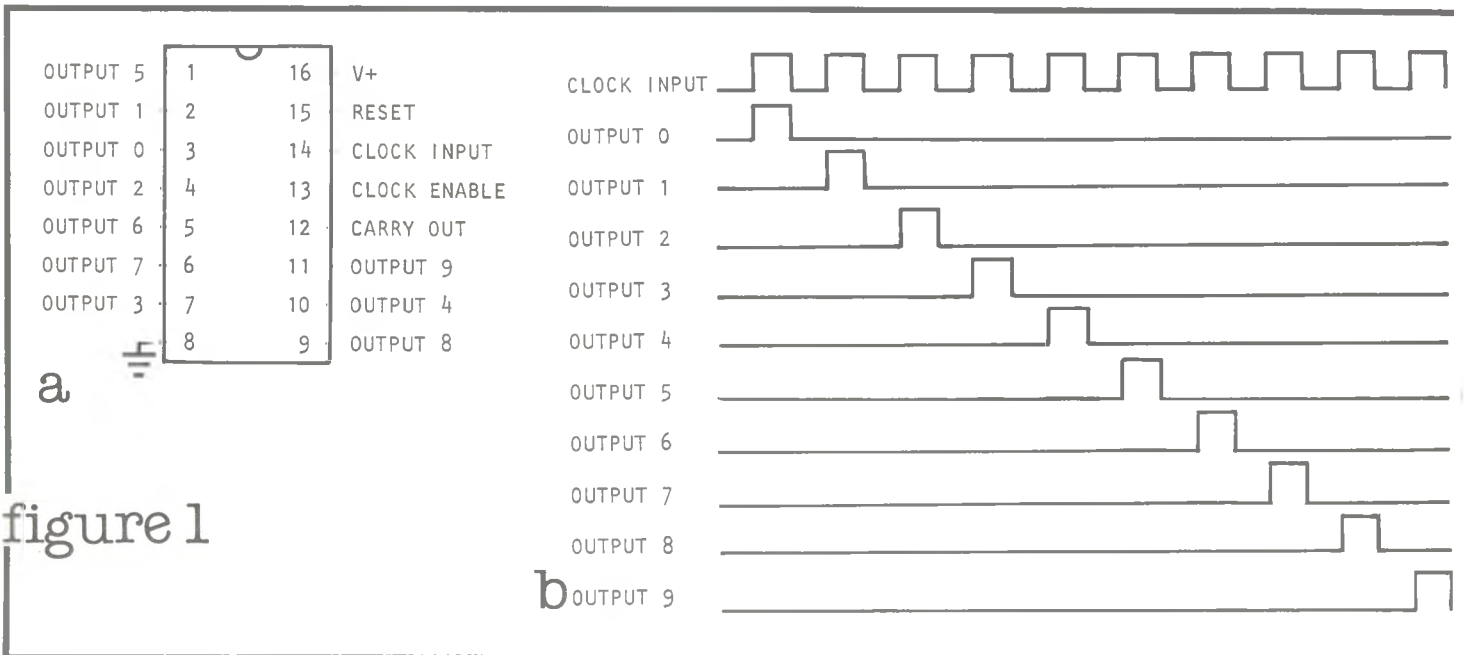

In addition to the inputs and outputs, there are CLOCK ENABLE, CARRY OUT, and RESET pins. With the clock enable pin low (grounded), the counter will advance with each positive going clock edge. Taking clock enable high (connected to V+) inhibits the counter, so that even if you feed in trigger pulses the outputs don't change.

The carry out pin doesn't concern us, since its function is to signal other circuitry that the counter has counted ten clock pulses.

My favorite feature of the 4017 is the reset pin - taking this pin high resets the counter so that output 0 is high and all other outputs are low. Therefore, by returning a particular output to the RESET input, we can create any counting sequence from two to nine events long. For example, by returning output 4 to the RESET input, the 4017 will count normally from 0 to 3. However, the instant that output 4 goes high, it resets the counter so that we're back to output 0

non-critical circuit; I built my prototype of perf board, with a smaller piece of perf board supporting the LEDs. Each LED inserts in a rubber grommet mounted in the front panel. Use sockets for all ICs.

I used mini phone jacks for the inputs and outputs, with closed circuit jacks on the four outputs. The shorting connections of each output jack buss together, with the buss terminating at the "normalised output" jack. This is very useful for multiplexing-type applications, where you can switch the 4 inputs into a common output. Note also that this circuit is bidirectional, so a signal plugged into the normalised output jack may be distributed sequentially to the 4 input jacks, which when used in this fashion become output jacks.

In PAiA synthesizers, audio and control voltage signals use different connectors. However, this module is equally suited to either audio or control voltage processing. In my system the fine line

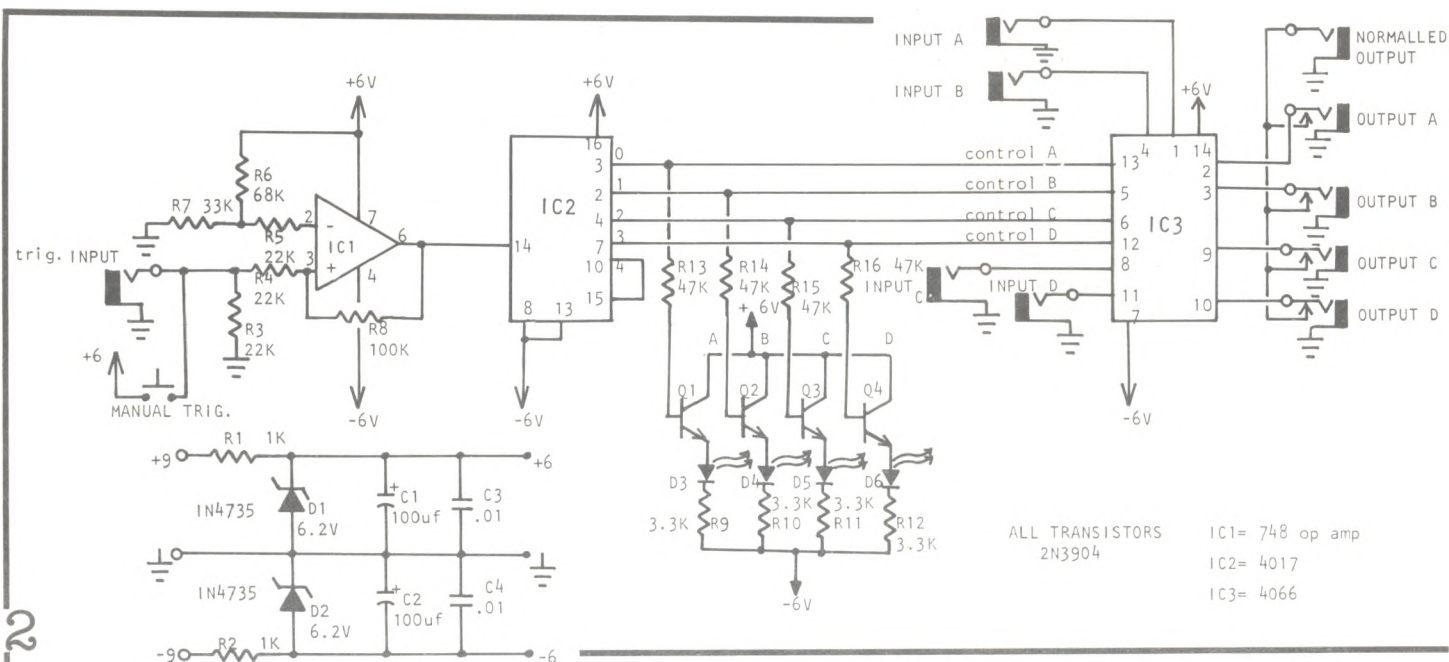

between audio and control was erased years ago, so I suggest that you do as I do and have a number of adapter cords lying around.

There is a problem, though, in switching the gate pulses that come out of the PAiA 4780 sequencer, since this is the only module in the PAiA line that has a non-standard voltage output (typically +13 to +15 Volts). This is higher than the maximum allowable input of IC3, which is +6 V. I solved this problem by making some attenuating patch cords (see figure 3). These lower the gate voltage to a nice, safe level for IC3. If you do use these special purpose patch cords,

signals with an audio frequency trigger pulse creates amplitude modulation "klang" textures.

2. PRESET PROGRAM BOX. This application involves the use of the manual trigger button. By setting up four different voices, or a four channel variable in a patch, you could select "preset" voices by stepping manually to the desired switch positions. This same principle can also work with control voltages.

3. AUTOMATIC PROGRAM BOX. By triggering the input from your keyboard trigger instead of the manual trigger button, you can step through each output every time you hit a note. This can provide, for example,

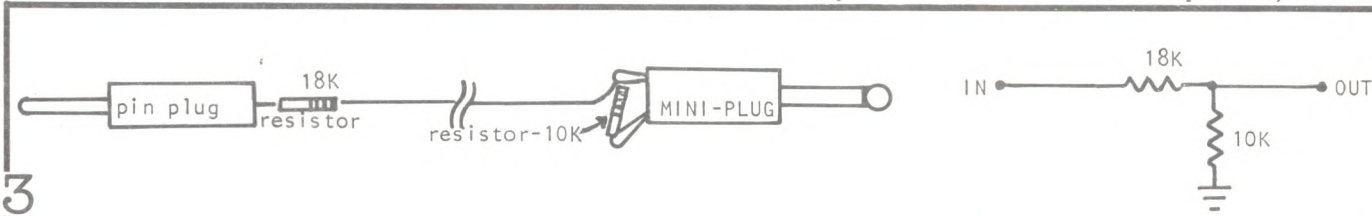

use a different colored wire (bright green, for example) so that they will be easily distinguishable from your normal patch cords.

USING THE CIRCUIT. Here are some examples to get you started in sequenced switching.

1. KLANG SOUND. The frequency response of the circuit is quite good, so gating one or more audio

alternation of four note voices (or four waveforms from an oscillator) as you play on the keyboard.

4. AUTOMATIC ENVELOPE CONTROL VARIATIONS. Figure 4 shows how to provide automatic variations in the envelope level going to a VCF. This creates a more animated and interesting sound than having a constant envelope level at all times. This same technique could switch different amounts of LFO modulation to a VCO for varying vibrato.

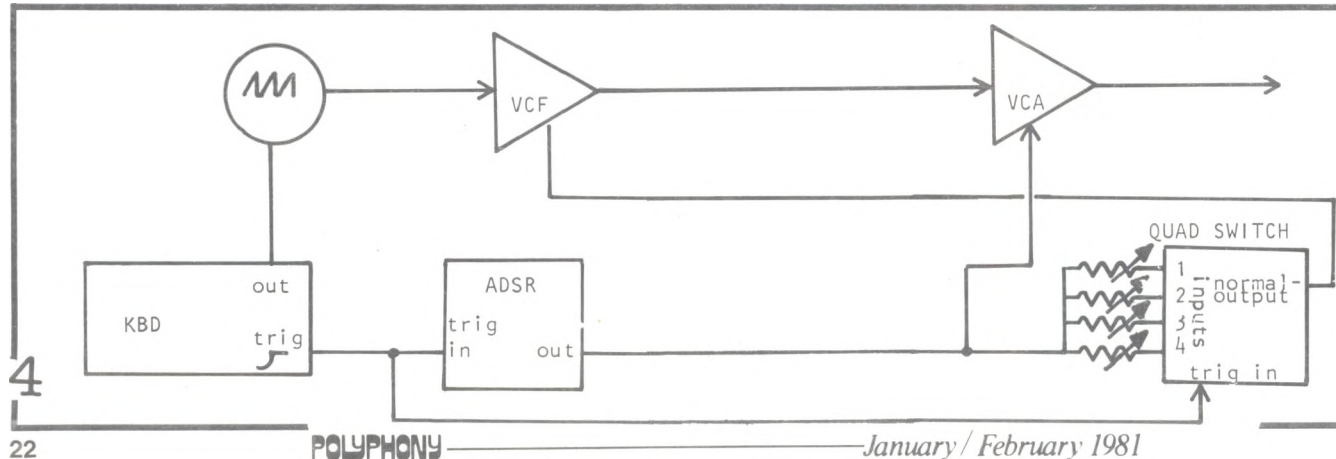

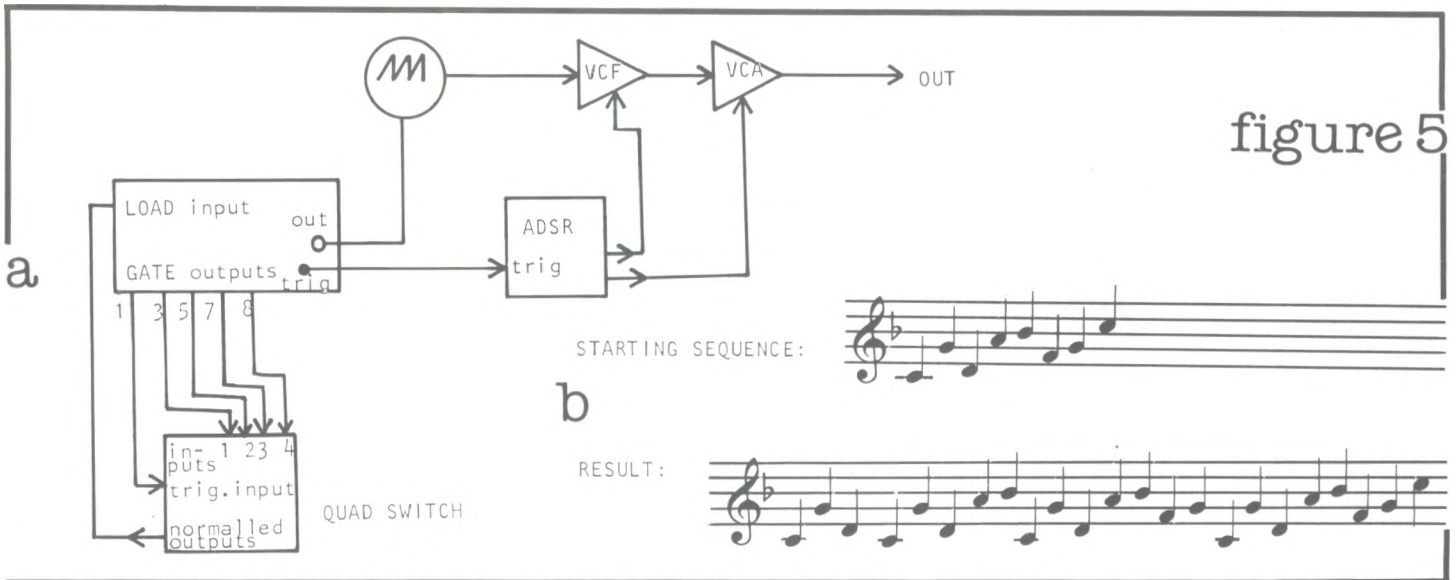

figure 5

5. EXPANDING THE 4780 SEQUENCER. A sequential switch can greatly expand the possibilities of the 4780 sequencer to "improvise" on a basic sequence. Figure 5b shows a sample sequence, and the resultant 23 note mutation produced by the patch.

Putting the switches in the audio path of a sequencer patch also presents interesting possibilities. Figure 6a shows one possible patch, while figure 6b shows a starting sequence and the 44 note sequence that results from using these switches. Using two switch modules to combine the technique of the patches in figures 5a and 6a can produce a sequence of 96 or more notes before repeating. Remember, these are only basic patches - using multiple switch modules can produce gigantic sequences. Mark Styles has covered patches of this nature in a previous issue of *Polyphony*.

FINAL NOTE. If this switch circuit interests you, I strongly suggest that you check out the level-sensitive switch presented in Gary Bannister's *Experimenter's Circuits* column on bar graph ICs (July/August 1979 *Polyphony*). I use one in my system, and it has lots of uses. You can split your keyboard up into 10 different voices (if you have that much

hardware), create random alterations of predetermined sequences of notes, and obtain timing triggers from absolutely ANY varying control voltage.

Another switch circuit that has been useful to me is a clockable toggle switch. This is basically the same as the circuit in figure 2, except that output 2 of 4017 connects back to the RESET pin, essentially turning the circuit into a "two channel sequential switch".

By themselves, switching devices may not appear all that useful. But using them intelligently as information routing devices in a patch multiplies your control possibilities. I hope that you will give this circuit a try, as it offers much ground for experimentation at little cost. *f*

References

Mark Styles; *The Synthesizer as a Medium*; *Polyphony* Sept/Oct 1979
 Ken Perrin; *Aries 300 system owner's manual*; *Sequencer/Switches* supplement
 Gary Bannister; *Experimenter's Circuits: Bar Graph ICs*; *Polyphony* July/Aug 1979

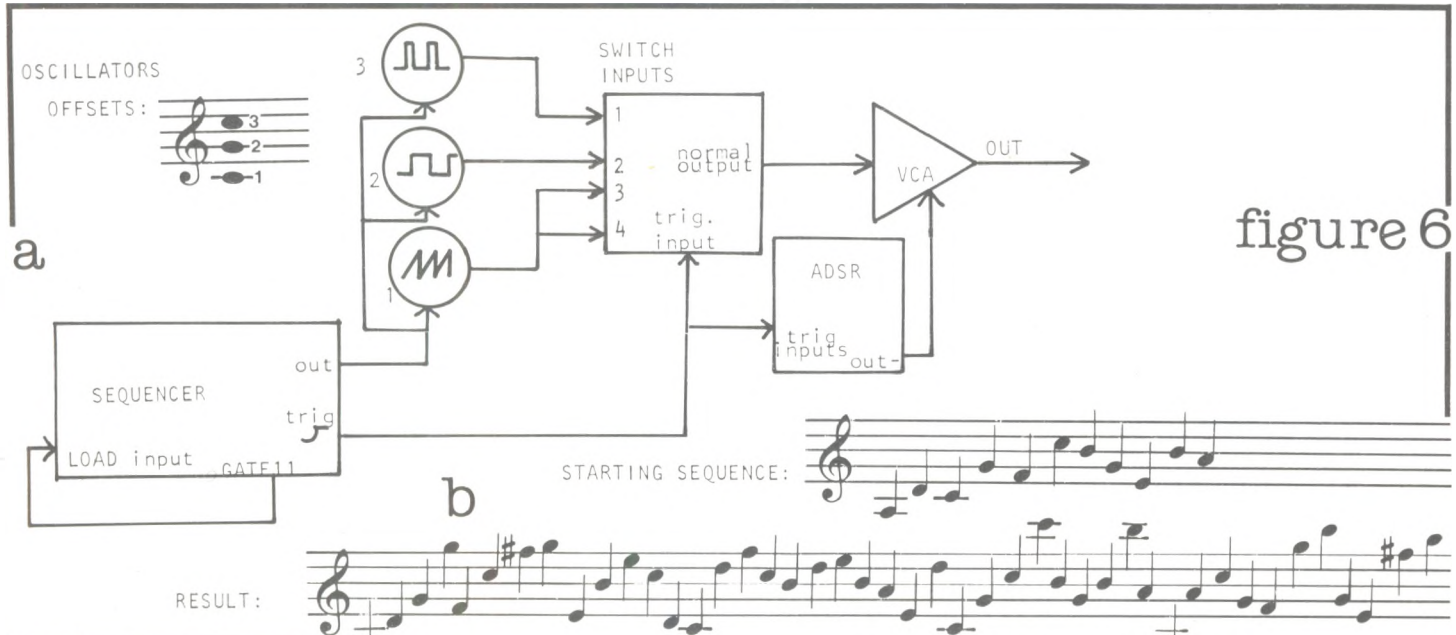
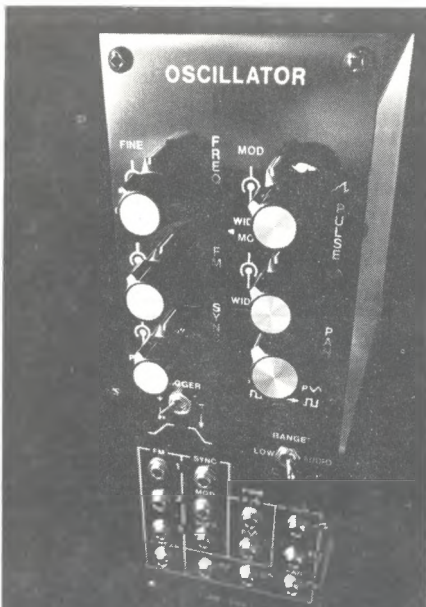

figure 6



Programmable.

RMS has something new. We've added new features, modules and improvements to make the Aries a great programmable, modular synthesizer. And it's affordable.

RMS Rivera Music Services

48 Brighton Avenue #11, Boston, Mass. 02134

PICKUP SWITCHING TRICK

by Steve Morrison

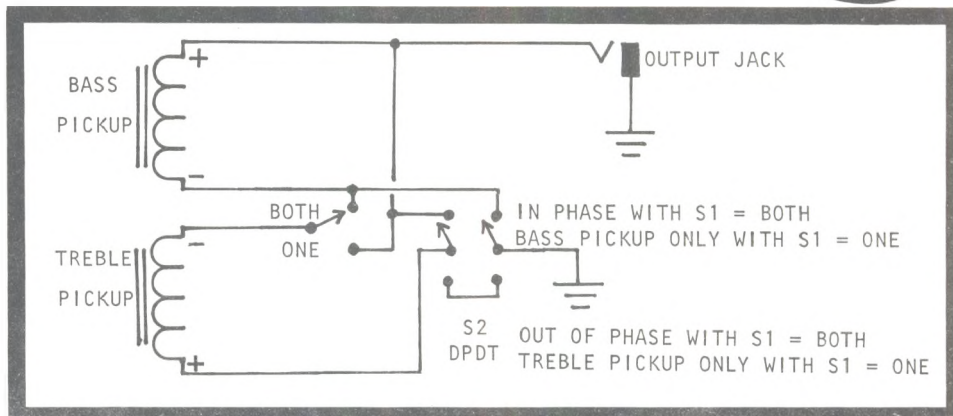

(Steve Morrison plays in one of Salt Lake City's only punk/new wave bands, "The Boards". His novel pickup switching circuit is pretty clever - check it out.)

between the treble and bass pickup. This eliminates the "switch that does nothing half the time" problem that annoys me so much about standard phase switches (gee, I feel better now...).

If you happen to have one of those economy type guitars with two pickups feeding on a single set of volume and tone controls (like a Telecaster) or no controls at all (which is the case with my Danelectro "Longhorn" 6 string bass), here's a neat way to add a new sound without routing out a space for more controls.

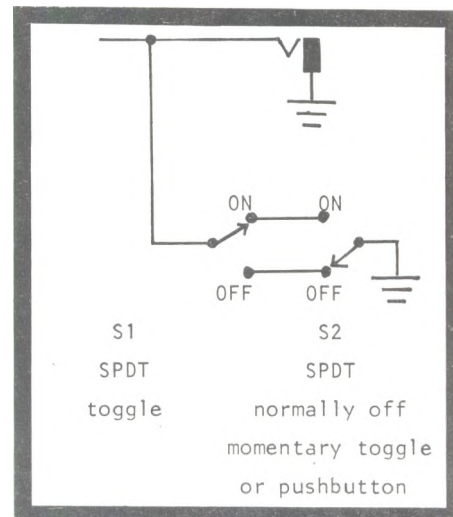

Out-of-phase pickup polarity reversal switches are becoming commonplace on guitars, but they have two major drawbacks: first, there's decreased output in the out-of-phase position, and second, the switch does absolutely nothing when only one pickup is selected (this really annoys me!). The switching circuit shown in figure 1 solves both these problems.

Now, for those of you who don't have any volume or tone controls on you stick (that's punk talk for axe), I'll bet you need a way to turn it on and off between songs, right? Figure 2 shows my solution: S1 is the master on/off switch, and S2 is a sneaky momentary pushbutton. When S1 is on, pushing S2 momentarily turns off the output signal; when S1 is off, pushing S2 momentarily turns the output signal on. Does this sound confusing? Well, if you put one of these in your guitar (or listen to early Who records) you'll see what I mean. *f*

To implement this circuit, you'll have to give up your standard 3 way toggle pickup selector, and install one SPDT and one DPDT switch in its place. S1 is a "one-or-both pickup" pickup selector. In the "both" position, S2 acts as a phase switch with the nifty feature of connecting the pickups in series when they're out of phase, thus providing a remedy for the low output problem mentioned earlier. In S1's "one" position, S2 acts as a "which one" selector so that you can choose

YOU TELL US!

What you want.

Had trouble obtaining certain items? Well, contact us and tell us what you want and what you would like to see from a mail order house. We believe that if we serve you, you'll serve us. So give us a call and leave a brief message, or drop us a line or two, telling us what you want. PGS wants the privilege of serving YOU.

— WE STOCK —

- **Linear IC's**
4739, 4136, 741, 1556, 555
- **OTA's**
CA3280, CA3080
- **Special Purpose IC's**
SN76477, MK50240
- **Resistors**
- **With many more items and services to come.**
- **Satisfaction guaranteed**

To be put on our mailing list and receive our flyer, write or call today!

PGS

ELECTRONICS SUPPLY

P.O. BOX 735 Dept. MO-1

TERRE HAUTE, IN 47808

812-894-2839

DOD MOD I

DOD MOD I: ENVELOPE FOLLOWER

by David DiFrancesco

With the stock 440 envelope follower, the resonance of the filter is fixed. However, there is a simple modification you can do to create as sharp a peak as you want - even to the point of oscillation.

Open up the case and examine the circuit board; you'll see a TL022 dual bifet op amp. A 430k resistor (may be 470k in some units) runs parallel to pins 5 through 8 of the TL022.

To add a variable resonance option, simply add a 100k trimpot in series with the 430k resistor. The easiest way to do this is to disconnect one end of the resistor, and re-connect this lead to the middle terminal of the trimpot. Then, connect either of the other trimpot leads to where the resistor lead used to be.

Once the trimpot is in place, rotate the dial until you get the response peak you desire. That's all there is to it.

(David DiFrancesco is an engineer with DOD Electronics.)

DOD MOD II: CHORUS

by Craig Anderton

The DOD 690 is one of the most affordable stereo chorus units on the market (for a complete review of the 690, see my "Notes" column in the December 1980 issue of Modern Recording & Music); so, it seems fitting that this should be one of the least expensive mods ever published in Polyphony. How expensive? Well, by spending 5 cents or less for a single resistor, you can expand the 690's chorus capabilities to include flanging and flanging/chorusing effects. If that sounds interesting, read on....

BACKGROUND. The 690 uses an SAD512 delay line that is initially set for slightly more than 20 ms of time delay. A triangle wave LFO modulates the delay time to create a chorusing effect; a width control determines the extent of this modulation. With the width control fully counterclockwise, there is no modulation and the delay is fixed at about 23 ms. Turning the width control clockwise allows the LFO to smoothly vary the time delay over the following ranges:

WIDTH CONTROL SETTING	MIN DELAY	MAX DELAY
max counterclockwise	23 ms	23 ms
9 o'clock	22 ms	24 ms
12 o'clock	17 ms	25 ms
max clockwise	14 ms	26 ms

This time delay variation creates the actual chorusing effect. As the above table shows, the greatest delay line variation occurs with the width control all the way clockwise.

THE MODIFICATION. The idea behind this modification is to change the delay time range variation into the flanging range, namely 0 to about 15 ms. While I was not able to get this wide a variation, the end result was close enough to give some reasonably good flanging effects.

The mod itself is so simple it doesn't even really need a diagram. Open the case (with the line cord unplugged, of course), and locate the LM324 IC. The closest resistor to the left-hand side of this IC (pins 1-7) is a 470k (yellow-violet-yellow) resistor... in fact, it's the only 470k resistor that's even remotely close to 324. Solder a 33k (orange-orange-orange) resistor in parallel with this part, and the modification is complete. If you want, you can drill a hole in the back of the box for a toggle switch to switch this resistor either in parallel with the 470k, or out of the circuit. By adding this switch, you'll be able to get the stock chorus settings when desired.

So what do you get for your efforts? You get a change in the way the width control acts, as given in the new chart below:

WIDTH CONTROL SETTING	MIN DELAY	MAX DELAY
max counterclockwise	23 ms	23 ms
9 o'clock	14 ms	21 ms
12 o'clock	7 ms	16 ms
max clockwise	4 ms	12 ms

What all this means is that at the maximum clockwise setting, you're getting right into the (continued.....on page 29)

BY PROFESSIONAL DEMAND

DDC OFFERS FREE ADVICE, PERSONAL SERVICE AND ONE-DAY SHIPPING OF THE FINEST MUSIC AND SOUND EQUIPMENT AVAILABLE ANYWHERE:

CROWN Traynor

KORG polyfusion

KELSEY

TEAC *Strobotuner*

LP *Zildjian*

TAPCO MULTITRON

CRUMAR Overcimm

SHURE

prophet

KRAMER

ARP

COLLATERAL

MXR

DiMarzio

REMO

YAMAHA

whirlwind

DMT

ROSS

OSC **ASHLY**

intersound

PLEASE CALL OR WRITE FOR PRICES & ORDERING INFORMATION - YOU'LL BE GLAD YOU DID!

DDC DICKSTEIN DISTRIBUTING COMPANY
1120 QUINCY PPY-SCRANTON, PA 18510
PHONE ORDERS WELCOME (717) 344 7469

Build a 50 watt/Channel Stereo Power Amp by Robert Rafuse

Now you can have a low cost, high quality, quiet, easy to build, and reliable 50 watt per channel power amp that compares very favorably with any power amp on the market. The secret of this high performance lies in hybrid power amp technology.

will concentrate on the Sanken 50W power amp modules since these are widely available and inexpensive. Each module only needs a 1 Volt peak-to-peak input signal to deliver its rated output power at 1KHz, with a maximum distortion of 0.5%.

converts AC to raw DC. S1 is the main power switch, L1 is a neon bulb (such as an NE-2) pilot light, and F1 is the main line fuse. C1 and C2 minimize any residual AC ripple from the supply.

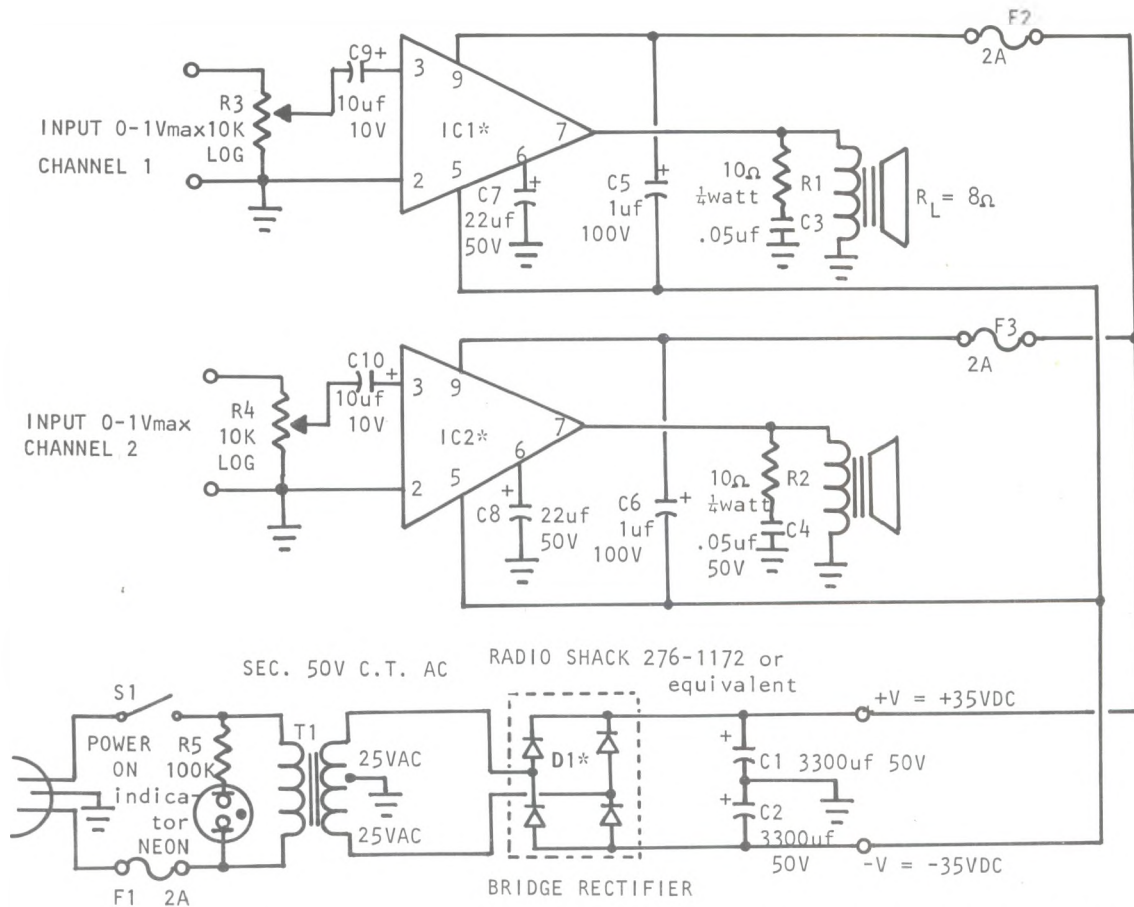

*note - attach to sufficient heatsink

(50WRMS per CHANNEL STEREO POWER AMP)

A hybrid amp is a solid state device that includes a 30 dB gain preamp, all power driver transistors, and integral heat sink in one compact, sealed package (sort of like a big op amp). The heat sink can be bolted onto a larger heat sink if necessary. These hybrid amps come in many shapes, sizes, and power levels from several different manufacturers, but this article

HOW IT WORKS. Referring to the schematic, the amp is powered by a bipolar power supply which not only saves us a few parts compared to a single polarity supply, but allows for direct coupling to the speaker (no coupling caps) for better sound quality. To obtain +33 Volts DC we use a 117V to 50V center tapped AC transformer (T1) and a full wave bridge rectifier (D1), which

The modules are Sanken S1-1050G 50W RMS power amps, which are designed to drive 8 Ohm loads and, unlike some of the older Sanken modules, offer built-in current limiting protection. For driving 4 Ohm loads, the recommended module is a Sanken S1-1050GL. F2 and F3 protect the speakers and modules in case of malfunction, while R1/C3 and R2/C4 suppress any unwanted

oscillations. C5/C6 provide additional power supply bypassing, while C7/C8 are feedback gain compensation capacitors.

On the input side, C9/C10 are input coupling capacitors that decouple DC between the amp and the source. Log potentiometers R3/R4 adjust the volume levels.

CONSTRUCTION. When you pick up your module, get the matching plug-in socket and spec sheets too. The spec sheets give you additional information on heat sinking, single supply operation, and operating at reduced power. The amp module heat sinks should bolt securely to a metal chassis (adding a little heat sinking compound never hurts), and all grounds should connect to one common point to prevent unwanted oscillations (important!). Use shielded cable for the inputs, but connect the shield to ground at one end only.

Mount the bypass and input capacitors as close to the modules as possible (you should be able to mount these right across the

socket pins) and connect the R1/C3 and R2/C4 RF noise suppressors at the speaker output terminals. Keep any AC power wires routed away from the amps, and keep the inputs away from the outputs. F1, F2, and F3 can be panel mounted fuse holders; if L1 is a standard neon bulb you will need to use the indicated dropping resistor, however some neon bulb assemblies already have the dropping resistor built-in in which case this part won't be necessary. I'd also recommend using a 3 conductor AC power cord, with the ground wire connected to the chassis at the single-point power supply ground.

Before turning on power, check between both supply lines and ground with an Ohmmeter - if you get a short circuit, start looking for wiring errors. Double check your wiring and the polarities of all capacitors; then, without any speakers connected, apply power with the volume control all the way down and check whether any voltage is present at the speaker terminals. If this voltage is either very low or non-existent, chances are all is well - turn off

power, wait a few minutes for the capacitors to discharge, hook up you speakers, and you're ready to go.

CONCLUSION. You might consider adding a few options, such as a time delay speaker connection circuit or a LED power meter. But no matter how simple or complex you make this amp, by carefully following the precautions given above you should have an easy to build and rewarding project for under \$100. So, get building and enjoy!

EDITOR'S NOTE. Robert isn't kidding when he says these are high quality modules. I've built several hybrid power amps; one of these amps even put a very highly touted audiophile power amp to shame - better transient response, more open sound, and lower noise. Whether for hi-fi, studio monitor, or instrument amp, these modules give a good account of themselves. About the only caution I would add is to beef up the heat sinks a bit if you plan to use these amps for live performance. *f*

BETTER ORDER before we change our minds

You've responded so well to our specials that we've come back with more. Stock up your lab at unprecedented prices, but remember that all quantities are limited; we will not be able to hold these kinds of prices forever. Sorry, due to processing costs we cannot include IC spec sheets, or accept COD/telephone orders on any items other than the 16K dynamic RAMs. IC numbers must include the special -S suffix or you will be charged our regular prices. Parts may be house numbered or dual marked

LOWEST PRICE EVER!! 16K Dynamic RAMs - 8/\$29

Just what you've come to expect from us: the lowest price ever on 16K dynamic RAMs, backed up with a 1 year warranty. These are top quality, low power, high speed (200 ns) parts that expand memory in TRS-80* I and -II computers as well as machines made by Apple, Exidy, Heath H89, newer PETs, etc. Add \$3 for two dip shunts plus TRS-80* conversion instructions. **Hurry! 16K dynamic RAM prices may never be this low again.**

TTL

7403-S	Quad 2 input OC	21/\$2
7410-S	Triple 3 input NAND	21/\$2
7413-S	4 to 16 line decoder/demux	6/\$2
7438-S	Quad 2 input NAND OC	21/\$2
7444-S	Gray to decimal decoder	8/\$2
7450-S	And-or invert	21/\$2
7472-S	JK M-S flip flop	21/\$2
7493-S	4 bit binary counter	10/\$2
7496-S	5 bit shift register	12/\$2
74122-S	Retriggerable one-shot	18/\$2
74151-S	8 channel mux	8/\$2
74155-S	Dual 2/4 demux	8/\$2
74159-S	4 to 16 line decoder/demux OC	4/\$2
74161-S	Synchro 4 bit binary counter	8/\$2
74163-S	Synchro 4 bit binary counter	8/\$2
74164-S	8 bit shift register	6/\$2
74190-S	Up/down decade counter	4/\$2
74192-S	Up/down binary counter	4/\$2
74194-S	4 bit bidirectional shift reg	4/\$2
74195-S	4 bit parallel shift register	6/\$2
74198-S	8 bit shift register	4/\$2

SAVE!

CMOS

4012-S	Dual 4 input NAND	12/\$2
4020-S	14 stage counter	4/\$2
4023-S	Triple 3 input NAND	12/\$2
4044-S	Quad R-S latch	4/\$2
4046-S	Phase locked loop	2/\$2
4071-S	Quad 2 input OR	12/\$2
4093-S	Quad 2 in NAND Schmitt trig	4/\$2
4507-S	Quad EX-OR	4/\$2
4510-S	BCD up/down counter	2/\$2

LINEARS

(package type: H - TO99 M - minidip D - dip TK - TO66)

201H-S	Improved 301 op amp	10/\$2
308H-S	Micropower op amp	6/\$2
703H-S	RF/IF amp	6/\$2
723D-S	Voltage regulator	6/\$2
741M-S	Compensated op amp	15/\$2
1458M-S	Dual 741	10/\$2
4558M-S	Dual 741	12/\$2
4195TK-S	Dual track 15V reg w/ data	2/\$2

TO-220 NEGATIVE VOLTAGE REGULATORS

7906	-6V regulator	2/\$2
7908	-8V regulator	2/\$2
7912	-12V regulator	2/\$2
7915	-15V regulator	2/\$2
7918	-18V regulator	2/\$2
7924	-24V regulator	2/\$2

Soldertail SOCKETS

8 pin	100/\$5.95
14, 16 & 18 pin	50/\$4.95
20 pin	40/\$4.95
24, 28 pin	30/\$4.95
40 pin	20/\$4.95

DC Robot Motors

DC fractional horsepower motor runs on about 1 to 5V. Not a servo motor by any means, but good for experimenting with robots, toys, games, etc. 10/\$2.95

Miscellaneous

RCA phono jacks - these are super quality, closed circuit jacks that are the best we've seen in years.

American made	20/\$1.95
2102 low power 1K static RAM	10/\$9.90
General purpose silicon signal diodes	50/\$2
GT5306 NPN darlington, min gain 17000	
25V 200 mA, TO92 package	100/\$8.95
NPN transistor similar 2N3904	100/\$7.95
PNP transistor similar 2N3906	100/\$8.95
4N28 opto-coupler 6 pin minidip	
MCT-2/IL-1 pinout	5/\$2
SN76477 complex sound generator	1/\$2.50
MA1003 12V DC clock module w/ case	\$19.95
Opto-Isolator Grab Bag - 50 mixed opto-isolators from a major manufacturer. Unmarked 6 and 8 lead minidips include single and dual types with diode, transistor, and darlington outputs. Test them yourself and save! Not recommended for beginners.	50/\$4

TERMS: Call for add. tax. Allow 5% shipping. Returns refunded. Orders under \$15 add \$2 handling. VISA and Mastercard orders for 16K RAMs call 415-562-0636, 24 hrs. Please include return address for 16K RAMs. Please specify shipping method.

FREE CATALOGUE: Free catalogue and price list for 16K RAMs. For no charge, send \$1.00 return address. Catalogue and price list will be sent.

GODBOUT

GODBOUT ELECTRONICS
Bldg. 725, Oakland Airport, CA 94614

MAGNETIC HARP

by Richard Wolton

The Magnetic Harp applies an input signal to a resonant system, thereby creating an acoustic signal processor. In this case, the resonant system consists of a stretched string; magnetic force applied to this string induce resonant vibrations, there by imparting unusual timbres to the signal being sent to this resonant system.

Figure 1 shows the basic idea behind the Magnetic Harp. A bronze wound steel string is stretched across two bridges, with magnets creating a fixed magnetic field. These two bridges are conducting, and have taps to which we can connect a power amp. In essence, the string itself becomes a very low resistance load (around 2 to 16 Ohms - a good match for many power amps, and since the load is essentially resistive, it places less strain on the amp than a heavily inductive load such as a speaker would). Applying a signal through the string produces a magnetic field around the string whose strength is proportional to the input signal.

The harmonic content of the applied signal will cause a magnetic interaction that will seek out resonances in the string. The overall effect depends on several factors, the most important being the natural harmonic resonance characteristics of the string. The fixed fields produced by the magnets, and their placement with respect to the string, are also very important. In order to create the proper physical vibrations, the lines of force should be perpendicular to the string and induced magnetic field. This will cause motion of the string that tends to be in a plane perpendicular to the polar axis of the fixed magnet's field. The placement of the fixed magnetic field determines the spectrum of resonant harmonics. For example, if the fixed magnet is placed so that the field lines are centered perpendicular to the midpoint of the string

(as in figure 1), the resonant will theoretically contain no even harmonics. This is because all even harmonics have nodes in the center of the string, therefore excluding any even harmonic vibration since there would be no magnetic interaction at that point. Similarly, other placements of the fixed magnetic fields, including multiple fixed magnetic fields of various positions and polarities, will modify the resonant spectrum and planes of vibration. Another factor to consider is the ratio of the string length to the physical size of the fixed field(s), as this will determine the accuracy of the spectrum modification.

With the type of setup shown in figure 1 the acoustic sound produced is quite soft; this is due to limitations of how much current you can actually pump through the string, and the strength of the available fixed magnet(s). Thus, it may be necessary to have another transducer to convert the string into a signal that can be amplified and further processed. Unfortunately, this transducer cannot be any kind that works on a magnetic principle (dynamic microphones, guitar pickups, etc.), as the field created by the current flowing

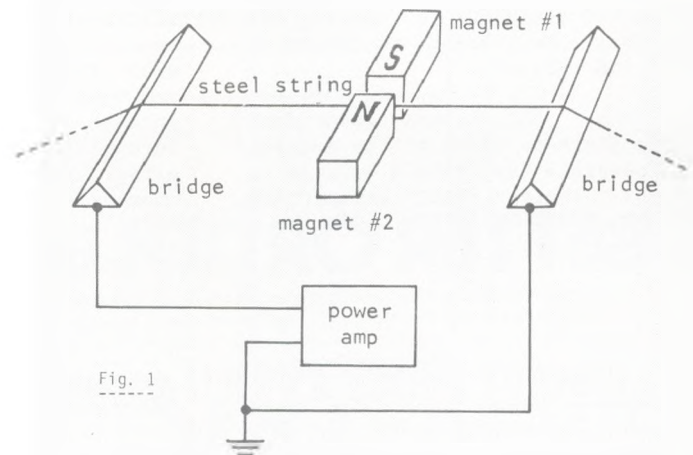

through the string will be directly induced into the transducer without including the overtones generated by the interaction of the string and magnet(s). It is possible to place the string between an optical transducer (such as a photo-transistor) and light source, since this will cause fluctuations in the light hitting the photo-transistor that are proportional to the string vibration. Although this works well in this application, there are some strange side effects: the signal will appear to be full wave rectified if the string is positioned exactly between the photo-transistor and the light source, and the system is also susceptible to ambient light (as well as the 60 Hz signal flowing through any AC powered light). A crystal microphone is a better way to amplify the Magnetic Harp effect, as it is more sensitive to some of the subtle resonances than an optic system would be. In order to accentuate these resonances, it is also important that the physical structure of the harp be designed with acoustic principles in mind. A hollow bodied structure with pleasing resonance qualities is desirable; a modified guitar, for example, works well.

For purposes of experimentation, I recommend various string gauges (steel only) and a set up that permits easy tension adjustment, such as a movable bridge. Also, new strings sound much better than old ones. To drive the signal, I have been using one channel of an audio stereo amplifier. As mentioned earlier, the resistance of the string is sufficient to give a reasonably good match. However, to be on the safe side you should probably use an amp that has current limiting and short circuit protection; a low voltage/high current amplifier design is recommended but not necessary.

It is also important to pay close attention to the amount of current being sent through the string, as it can get quite hot and burn up if you're not careful. Note too that as the temperature of the string increases, the fundamental gets lower.

Aside from these limitations, the Magnetic Harp is a relatively noncritical device that offers a new type of concept in signal processing. If you come up with any unusual applications, or have modifications to the system, please send them to Polyphony. *f*

(continued.....from page 25)

heart of the flanging range. Thanks to the compansion included in the 690 circuitry, the flanging sound is real quiet; and it sounds GREAT in stereo! What's more, even with the modification, you can still get pretty good chorusing sound with the control set at 9 o'clock (however, the stock 690 does sweeps over a wider range when chorusing). In between these settings, you get a mix of chorusing and flanging that sounds quite good.

CONCLUSION. With one resistor, you've added several new effects to the 690. An added bonus is that at shorter delay times, the SAD512 is inherently quieter so that noise levels at the flanging and the flanging/chorusing settings of the width control are excellent - even with low level input signals.

Many people will be interested in the 690 simply because it is an affordable way to get that wonderful chorusing sound; but add this mod, and you'll have more than a nice chorus box on your hands.

Postscript: Here's some additional information for those of you who like to keep up with analog delay line techniques. The SAD512 does not require a traditional clock driver, since one is included on the chip. As a result, there is only a single clock pulse input to the 512; you can monitor this clock signal on pin 8 of the 4001. If you have an oscilloscope with a calibrated time base, the delay time is almost exactly equal to the clock period (in microseconds) X 1000. So, a clock period of 20 microseconds means a delay time of 20 milliseconds. *f*

DOD MOD

DOD MOD II: CHORUS →

EKx Series Exponential Module Cards

Featuring
CES Audio/
Synthesizer IC's

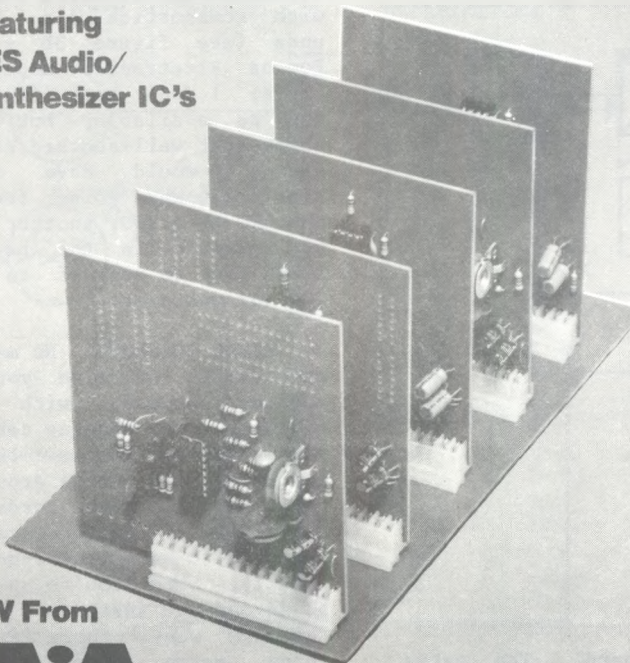

NEW From
PAIA
ELECTRONICS, INC.

Dept. 1-Y 1020 W. Wilshire Blvd.,
Oklahoma City, OK 73116

EKx-10 ADSR

envelope generator with exponential control of Attack, Decay and Release times over a guaranteed .002 to 20 second range. No control voltage feed-through.. \$24.95 plus postage (\$1.00)

EKx-20 VCF

with exponential control of pole frequency over a 10 octave range. Jumper programmable for 24 dB/Oct. LP, HP, BP or All Pass response. Voltage controlled resonance. Low noise, 86 dB below max. output. \$26.95 (\$1.00)

EKx-30 VCA

low noise, low distortion, wide bandwidth, low control voltage feedthrough. Both exponential and linear control voltage inputs simultaneously available..... \$24.95 (\$1.00)

EKx-40 Full Feature VCO

Full feature VCO with ramp, triangle and voltage controlled pulse. Exponential control of frequency over accurate and stable 100,000:1 range. Linear FM input and hard and soft sync. \$29.95 (\$1.00)

Each kit features the Curtis Electromusic I.C.'s to implement a full function Voltage Controlled Card. All connections are brought to the card edge in a configuration compatible with Molex or 22 pin .156 center edge connectors.

SEND EKx10 EKx20 EKx30 EKx40; \$ _____ enclosed.
 TELL ME MORE, Send set of 4 IC spec. sheets; \$1 postage & handling enclosed.
 SEND FREE CATALOG

name: _____

address: _____

city: _____ state: _____ zip: _____

The Normalled, Live Performance 4700/S

by Doug Llewellyn

Normalled synthesizers are very convenient for live performance, but for my first synthesizer a modular system seemed to suit my needs. So, I chose a 4700/S and despite all those patch cords, still managed to use it in live performance by applying a trick or two.

My playing situation wasn't too unusual; while doing time in the Air Force in Germany, I became involved in a musical revue/variety show put on by the base recreation center. Besides touring a few bases in the area, we ultimately ended up as one of the acts in the open house festivities at Templehof Airport in West Berlin. In addition to playing rhythm guitar, I used the 4700/S for background melodies and sound effects.

NORMALLING THE 4700/S. Since no elaborate patches were required, I came up with the normalled patch scheme shown in figure 1. This covered about 80% of my playing needs, so that the

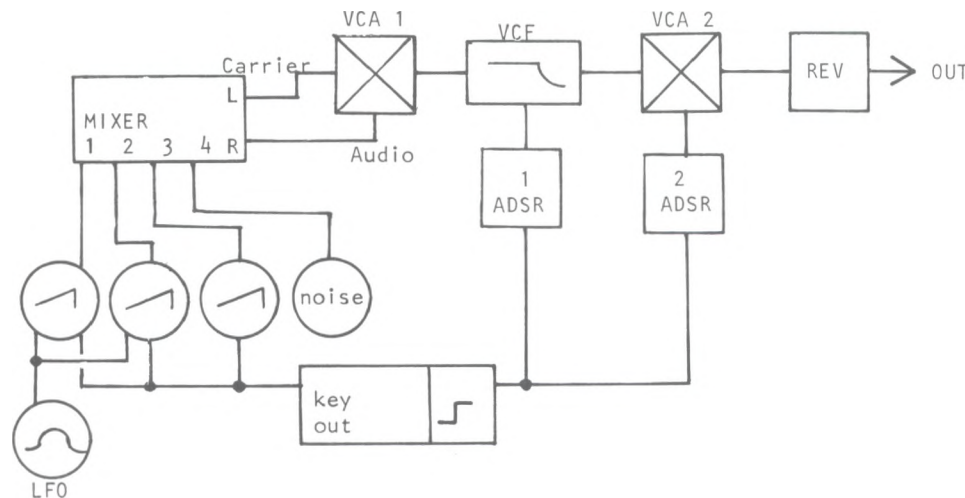

1

only plug-pulling I had to do was occasionally bypassing the first balanced modulator/VCA, changing VCO waveforms, and routing the filter output.

ADDING A PITCH CONTROL PRESET.

We opened our shows with the old white noise/howling wind cliché, which changed to rising oscillator sounds. An off stage voice did a space launch-style countdown while

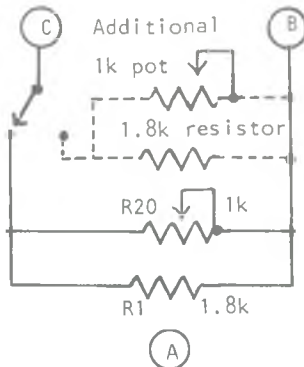

2

this was happening, and when he said "liftoff", the rest of the band would kick in (a bit corny, but the audience ate it up). Seeing as how I also had to play along with the band later on (preferably in tune!), twisting the pitch control around could have created problems. So, I added the preset modification shown in figure 2 to the 2720-9

playing, while the other could be used for special effects and the like.

SIMPLIFYING PATCH CORD CONNECTIONS. There were a couple of tricks I used to make patching easier. First of all, when the gig was over I unplugged the wires going to the keyboard (CV out, trigger, ground) and plugged these into unused jacks on the modules. Thus, the two module cases could be closed with the patch cords already half-ready to go when I set up for the next show.

Since the three oscillators were being controlled by a single control voltage output, I took two patch cords and joined them in a "T" configuration (see figure 3a). The long end of this cord went to the CV out jack, while the other three ends went to the oscillators. This cut down on the cord count and freed the multiple jacks for other applications.

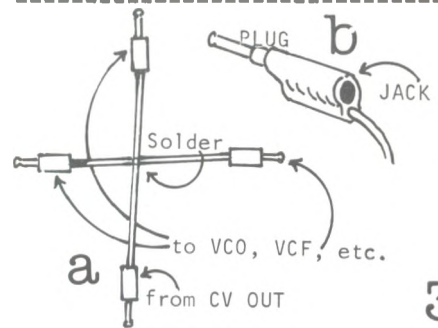

3

Another way to cut down on clutter involves using patch cords with combination pin plug/jack ends (see figure 3b - I used Pomona Electronics model #P-36 cords; I don't know offhand where they're available, but I would think most well-stocked electronic stores would have something similar). When going from, say, the LFO to a VCO, another plug can be inserted in the back of the first plug to run off to another VCO (or whatever).

FINAL COMMENTS. No matter how many miles of wire you've got running around, with careful planning most changes can be made with knobs rather than by switching patch cords around. The only people those cords should intimidate is the audience; you're supposed to know what's going on. Finally, when you're up there on stage and you just can't seem to remember where those last two or three patch cords go, just remember that wise old saying - "If you can't dazzle them with brilliance, baffle them with bull". In other words - fake it!

(continued.....from page 15)

PATCHES:

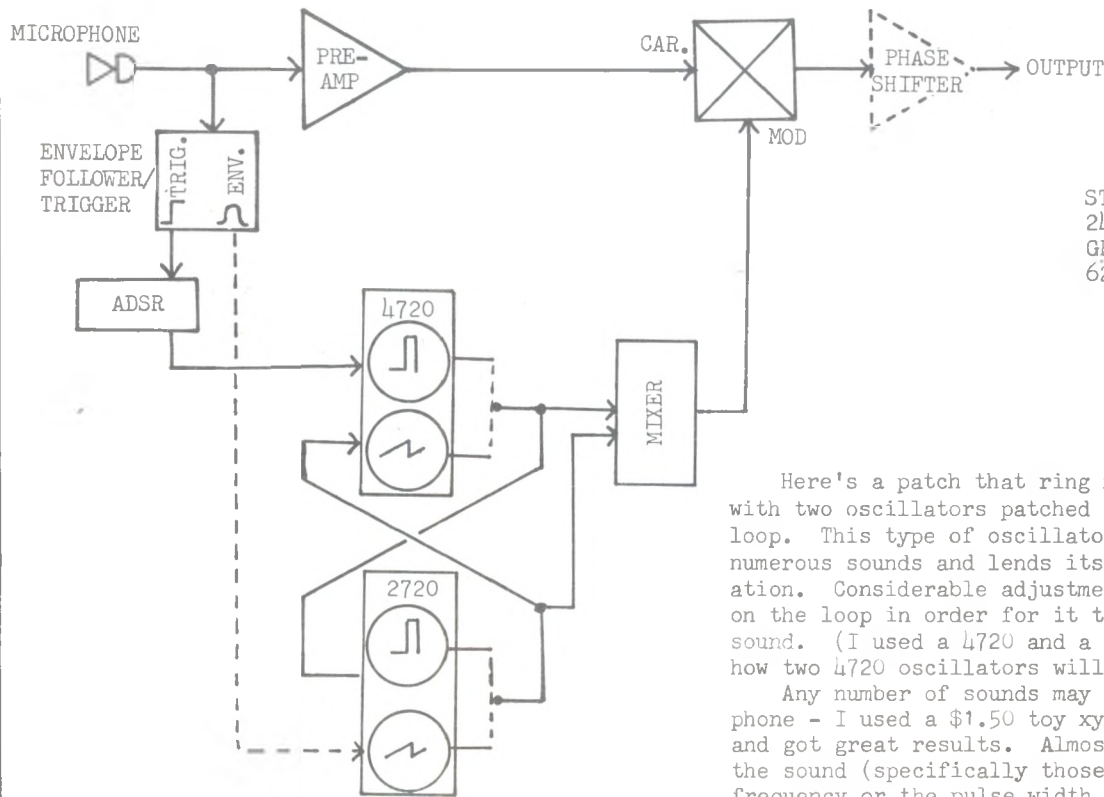

STEVE JONES
2413 SUNBURY
GRANITE CITY, ILL.
62040

Here's a patch that ring modulates a microphone with two oscillators patched in a voltage/frequency loop. This type of oscillator loop can generate numerous sounds and lends itself to much experimentation. Considerable adjustment might have to be made on the loop in order for it to produce the desired sound. (I used a 4720 and a 2720 VCO; I'm not sure how two 4720 oscillators will work in this patch.)

Any number of sounds may be used for the microphone - I used a \$1.50 toy xylophone and a typewriter and got great results. Almost every control changes the sound (specifically those that control the frequency or the pulse width of the oscillators).

HORNS PAIA P4700J SYNTHESIZER or OTHER POSSESSING SIMILAR CAPABILITIES

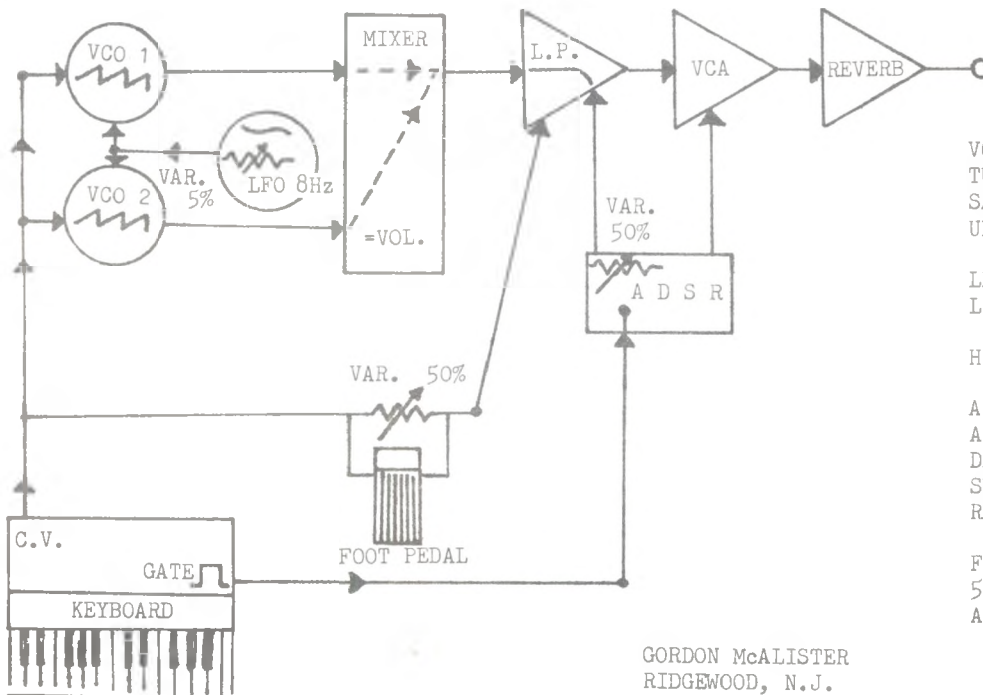

VCO 1 & VCO 2
TUNE 30%
SAWTOOTH OUTPUT; ADJUST FOR
UNISON/FLANGING EFFECTS

LFO - 8Hz 5% VAR.
LOW PASS FILTER

HIGH-FREQ. 75% Q 5%

A.D.S.R.
ATTACK - 15% VAR. 5%
DECAY - 40%
SUSTAIN - 100%
RELEASE - 15%

FOOT PEDAL
50% VAR. FOR "SWELL" EFFECT
AND EXPRESSIVENESS

GORDON McALISTER
RIDGWOOD, N.J.

The people who publish *The Audio Amateur* welcome your subscription to our NEW publication. . .

SPEAKER BUILDER

IF ONE HALF THE CASH you spend on your audio system should be invested in your speaker, why not build it yourself? Nearly 100,000 Americans will do so this year—why not you too? Your dream speaker just may be possible *only* by doing it yourself. There's a lot of help around already and now this new quarterly publication from the publishers of *The Audio Amateur* promises an assortment of articles that are comprehensive and a mix of both simple and advanced projects about all types of speakers.

- ★ Bass Reflex
- ★ Horns
- ★ Electrostatics
- ★ Transmission Lines
- ★ Infinite Baffle
- ★ Specials: Ribbon, Air motion transformers and many others.
- ★ All the basic data on passive and electronic crossovers.

There will be kit reports on building the many speakers and enclosures now available in kit form and a roundup of suppliers of drivers, parts, and kits.

We have articles in hand that range from the ultimate (650 Lbs each) to very simple extension speakers. From time delayed multi-satellites to horn loaded subwoofers. There will be modifications of many stock designs as well as resurrections of great classic designs out of the past.

We'll be doing basic articles on the design theory behind each of the great classical speaker formats. And you'll find lots of reference data on design formulas, crossover coil winding guides and much more. **Speaker Builders** will have a lot to say to each other in the column on tips, photos of systems, in the letters exchange as well as swaps of gear and data in the columns of free classified ads.

Standard format 8 1/2 x 11" on good book paper, with clear diagrams and photos and all the data you need to build each project successfully and without undue hassle, **Speaker Builder** will be reader-centered and reader supported and NOT a thinly disguised marketing medium catering to advertisers. Ad ratios will never exceed 40% (the national average is over 60%). Guarantee: if you are not satisfied with **Speaker Builder** the publisher will refund the unused portion of your subscription.

The price is \$10 per year, for the four quarterly issues, or just \$18 for two years. Use your charge card to execute your order (signature with order blank below, please) or call our charge card order desk for **Speaker Builder** at (603) 924-6526 from 8am to 4pm on weekdays and leave your order. Tell your friends about **Speaker Builder** or include their names with your order and we will send them full information about the publication and how to subscribe.

ORDER BLANK

SPEAKER BUILDER Magazine

M50

P.O. Box 494, Peterborough NH 03458 USA

Enter my charter subscription to **SPEAKER BUILDER** for one year at **\$10.00.**

Make that a two year charter subscription at **\$18.00.**

Check enclosed Charge to my MasterCharge Visa charge card.

Expire____/____

Name _____

Street & No. _____

Town _____ State _____ ZIP _____

I understand that the unexpired portion of my subscription will be refunded after my first issue if the magazine is unsatisfactory for any reason. Make checks and money orders payable to Speaker Builder. Rates above are for USA only. Outside USA add \$1.50 per year for postage. Non U.S. checks must be drawn in U.S. currency only.

EQUIPMENT EXCHANGE

List your equipment or services for sale, trade, or wanted, plus job openings, positions wanted, and so on. Keep listings brief; enclose \$1.00 for each 10 words. Prices, zip, and phone numbers count as one word each. Display classifieds are available for commercial ads; rates are \$12 per column inch (minimum, camera ready). Respond directly to the advertiser. Please don't write to POLYPHONY. Polyphony is not responsible for claims made in ads, or the results of any transactions. We reserve the right to edit or refuse any ads submitted.

Literature

SYNEX

The Synthesizer Exchange Newsletter

A forum for discussion between thinking electronic musicians. For sample issue send 50¢ to:

Synex Newsletter
P.O. Box 294
Corte Madera, CA
94925

Recordings

EXCEPTIONAL QUALITY electronic music by Gil Trythall, money back guarantee, LUXIKON II/ECHOSPACE LP \$7.95 ppd. Box 2281, Westover, WV 26505.

Yes, Richard Bone, Syd Barrett, Tibetan Bells II, Neuronium, Puerto Rican Progressive Music, as well as import and independent music is covered in SURFACE NOISE #2. \$1.00 postpaid from John Loffink, 428 Citrus Road, Melbourne, FL 32935

Services

CA3280

DUAL OTA

AS FEATURED IN POLYPHONY
JAN-FEB 1980 ISSUE

QUAN 1-9	\$3.95
QUAN 10-19	\$3.49

FREE DATA AND APPLICATION
NOTES WITH EACH ORDER

ELECTRONIC MUSIC CONSULTANTS
533 SAN BLAS PLACE
SANTA BARBARA, CA. 93111

CALIFORNIA RESIDENTS ADD 6% SALES TAX
WRITE FOR LATEST FLYER

WE PAY SHIPPING IF YOU
MENTION POLYPHONY

Music equipment

MY ROAD DAYS ARE OVER-DIABETES HAS SPOKEN! Must sell Yamaha CP-70B Piano and CS-60 8 voice Poly-Synth; Rhodes 73 key Piano w/slider pots & aux. power supply; Hammond B-3 in Trek II case w/Leslie 760; Hohner Clav. D-6; and Sound System w/ 6 channel mixer, Dual 100 power amp, amp rack & Electro-Voice S18-3 speaker. All have Viking road cases. Also have some mics, stands, etc. B. E. Harrington, 4335 1/2 N. Western Ave., Okla. City, OK 73118 (405)521-0931.

PAIA Organtua in excellent condition with external modules 4710, 4730, 4740, power supplies, all in compact case. Patch cords included. \$300 takes all. (504)737-9237

E-Mu Synthesizer, owned by Ned Lagin and used extensively on Grateful Dead tours. Mono keyboard with computer port; four oscillators, 4 dual envelopes, 2 lag processors, dual reverb, 5 VCA/mixers, analog switches. ADSR's fully voltage control. And much more! Originally \$9500, now \$4900/offer. Contact J. D. Sharp, Sharp Audio, (415)454-0767, or write to 802 Fourth St., San Rafael, CA 94901. Also fully franchised Polyfusion sales.

Must sell new Paia Programmable Drum Set #3750 \$110.00 Please call (213)865-7717

Two assembled E-mu Synthesizer Boards, each board contains 2 - VCO's, 2 - VCA's, 2 - VCTG's, and a VCF. Prime quality, temperature stable. Connectors and Full documentation. Requires + 15 volts. One for \$300, both for \$550, well below cost. Kenny Winograd, Seven Greenbriar Drive, North Reading, Mass 01864

Assembled: 4710, 4720, 4730, 4740, 4750, (2) 4770, 8780, 5-octave Pratt-Read Keyboard with EK-3 kit all in solid wood cabinet. One year old, \$300. Stanley Norris, Rt. 2 Box 181L, Gentry, Ark. 72734 (501) 736-8011.

equipment

P4700C, full RAM and MUS .01, 2 road cases filled with 6 4720, 3 4730, 2 4710, 2 VCA, 2 reverb, 2 mixer, 2 Quash, Electronic Mistress, LED VU, unused. \$1300 invested; \$800 or offer. Also RCA 5Mhz portable scope with dual-tracer, \$400 new; \$160. Teac 3340 deck with ten 10 1/2" tapes, perfect condition, \$700 or offer. Complete Controls, 605 Arch, Ottawa, IL 61350 (815)434-1425.

For Sale: one Teac A3440 4 track 1/4" reel to reel tape recorder with syc for home recording. 1 year old, 3 months of use; 1 year warranty left. Asking \$1000.00 or reasonable trade. Jon Biddix, phone (618)656-9196 or (815)875-1728

For Sale: P-4700/J with 8700 computer controller. Includes MUS 1 PROM, some software on cassette and all documentation. Completely assembled, \$600 or best offer. 4700/A Sequencer Package, assembled, \$80. Phlanger assembled, \$45. Must Sell. Jim Speedy, 1504 A Windsor, Austin, TX 78703 (512)476-4721

Expand the memory and I/O capabilities in your PAIA 8700 micro controller. The 8700 expander has 1K of RAM, 4 I/O ports, 4 programmable timers plus extras. Introductory price \$69.95 (kit). To order or for more info write Electronic Music Consultants, 533 San Blas Pl., Santa Barbara, CA 93111.

Wanted

Would like to contact others for exchange of ideas, designs, modifications, problems with same, possible equipment exchange, etc. PAIA and exponential items. Jim Rice, 577 33 Road, Rt. 1, Clifton, CO 81520

Trade mixer Pac and sustain for your Gnome-Oz. David Buckland, Box 352, Harrison Hot Springs, BC VOM 1K0 CANADA (604) 796-9916

the CATSTICK synthesizer controller

THE BETTER ALTERNATIVE TO WHEELS, RIBBONS, PRESSURE PADS, KNOBS, SLIDERS AND PEDALS, FOR ANY PATCHABLE SYNTHESIZER

WHAT IS IT?

The CATSTICK is a precision, spring-loaded joystick controller that lets one hand control four different modulation settings - one for each of the joystick directions. By moving the stick off axis, combination modulations of different proportions are possible. When the stick is released, it springs back to its vertical, zero modulation position.

HOW DO YOU USE IT?

For portable synthesizers, like the CAT, Odyssey, or Minimoog, you can connect the CATSTICK outputs to the VCO, VCF or VCA inputs normally intended for footpedal controls. This lets you use the CATSTICK LFO's and control voltages to modulate the synthesizer as the joystick is moved. In patchable systems like the ARP 2600 or Modular Moogs, you can connect the CATSTICK VCA's in series with patchcords to allow real-time control of synthesizer patches.

WHO CAN USE IT?

If you own a MINIMOOG, CAT, KITTEN, ODYSSEY, 2600, OBERHEIM, MODULAR

SYSTEM or any other synthesizer with control voltage inputs, you can use a CATSTICK. And, if you don't have control voltage inputs or want more, we'll show you how to modify your instrument or do it for you at a very modest cost. We can also modify your synthesizer for "single cable" connection to the Catstick outputs.

PATCHING VERSATILITY

Included are four VCA's (each externally accessible), two wide-range LFO's with rate monitors, and a complete internal voltage processing system. The twenty-jack rear panel patch bay allows access to all of the internal control voltage signals and makes the CATSTICK a versatile addition for both performance-oriented and studio synthesis systems.

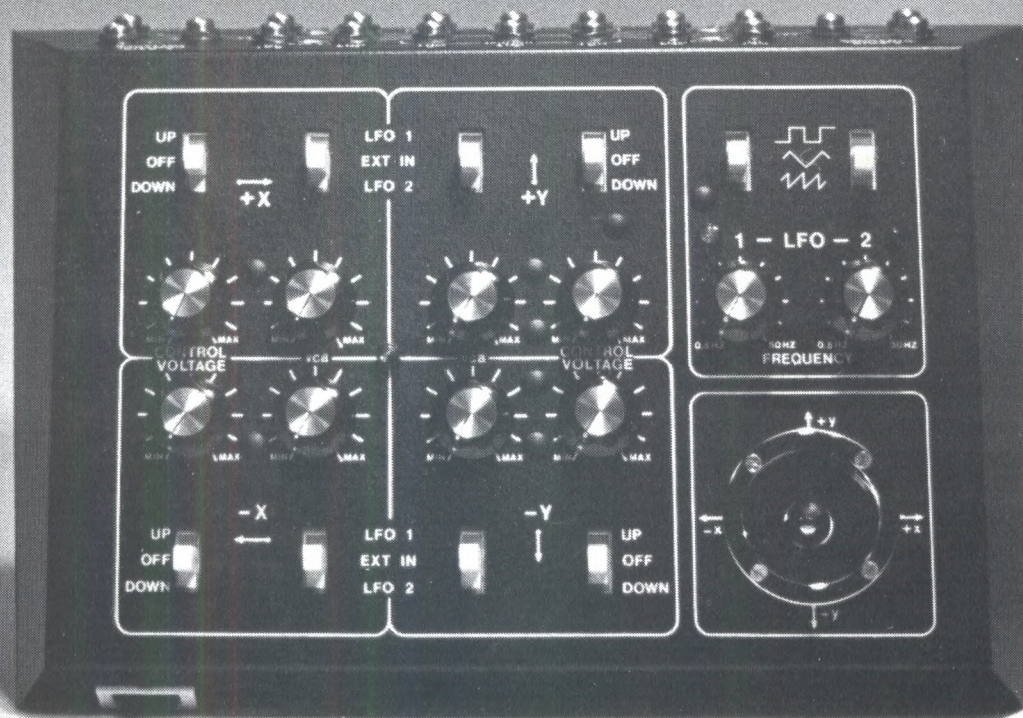
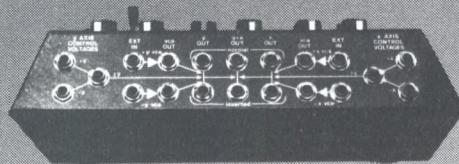

For further information, and the location of your nearest dealer, write:

OCTAVE-PLATEAU
Electronics Inc.

928 BROADWAY, 7th FLOOR, N.Y.C., N.Y. 10010
OR CALL (212) 673-4205

Waiting for a lead synthesizer that has it all?

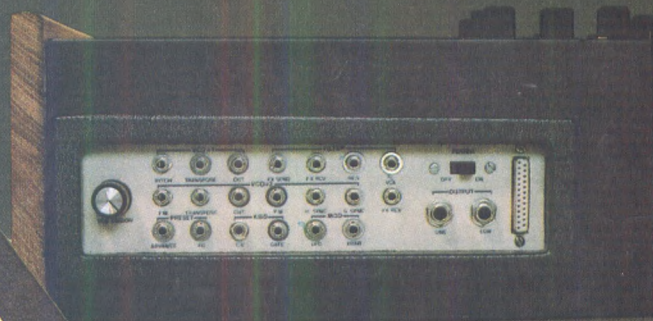

Your wait is over!

PROTEUS ITM PROGRAMMABLE PRESET LEAD SYNTHESIZER

You've always had a lot of options.

You could have the convenience and easy operation of a normalized synthesizer if you were willing to give up the versatility of modular equipment.

Or the unlimited spectrum of tone colors and timbres of modules if you didn't mind the cumbersome patch cords and time required to set up or change a patch.

You could have programmable presets if you could raise the bucks, or low-cost equipment if you could stand the snap-crackle-pop.

You could even have such technically innovative features as computer control of voice and sequence if you had the technical savvy to design it all and make it work.

Now you have another option. YOU CAN HAVE IT ALL. Wide range, precise, low-noise, presets, meaningful patch bay and an easy-to-use computer interface.

All at a price that's nothing but unbelievable.

Want to know more? Proteus I's Using/Assembly manual which includes a demo tape will answer all of your questions. The price, \$10.00 is refundable upon purchase of either the kit or assembled model.

PART OF THE NEW GENERATION FROM

PAIA Electronics, Inc.

1020 W. Wilshire, Oklahoma City, OK 73116 - (405)843-9626

**CHARGE ORDER? Call our 24 hour Demo/Order line
405-843-7396**

- I'm convinced, send Proteus I, \$699.00 enclosed. (shipped Freight Collect)
- Send the easy-to-assemble Proteus I Kit, \$499.00 enclosed. (Freight Collect)
- Tell me more, Rush the Assembly/Using manual & demo tape for Proteus I. (\$10.00 enclosed, refundable)
- Send free catalog

Name: _____

Address: _____

City: _____ State: _____ Zip: _____

Visa _____ MC _____ Card No.: _____

PAIA Electronics, Dept. 4Y, 1020 W. Wilshire, Okla. City, OK 73116