

# POLYPHONY

*ELECTRONIC MUSIC & HOME RECORDING*

*July - Aug.*

*1981*

*\$2.50*

*ISSN: 0163-4534*

## GUITAR ELECTRONICS

INPUT/OUTPUT STRUCTURES

**MODIFY:**

**FENDER AMP**

**MXR PHASE 100**

**MORE GR-500**

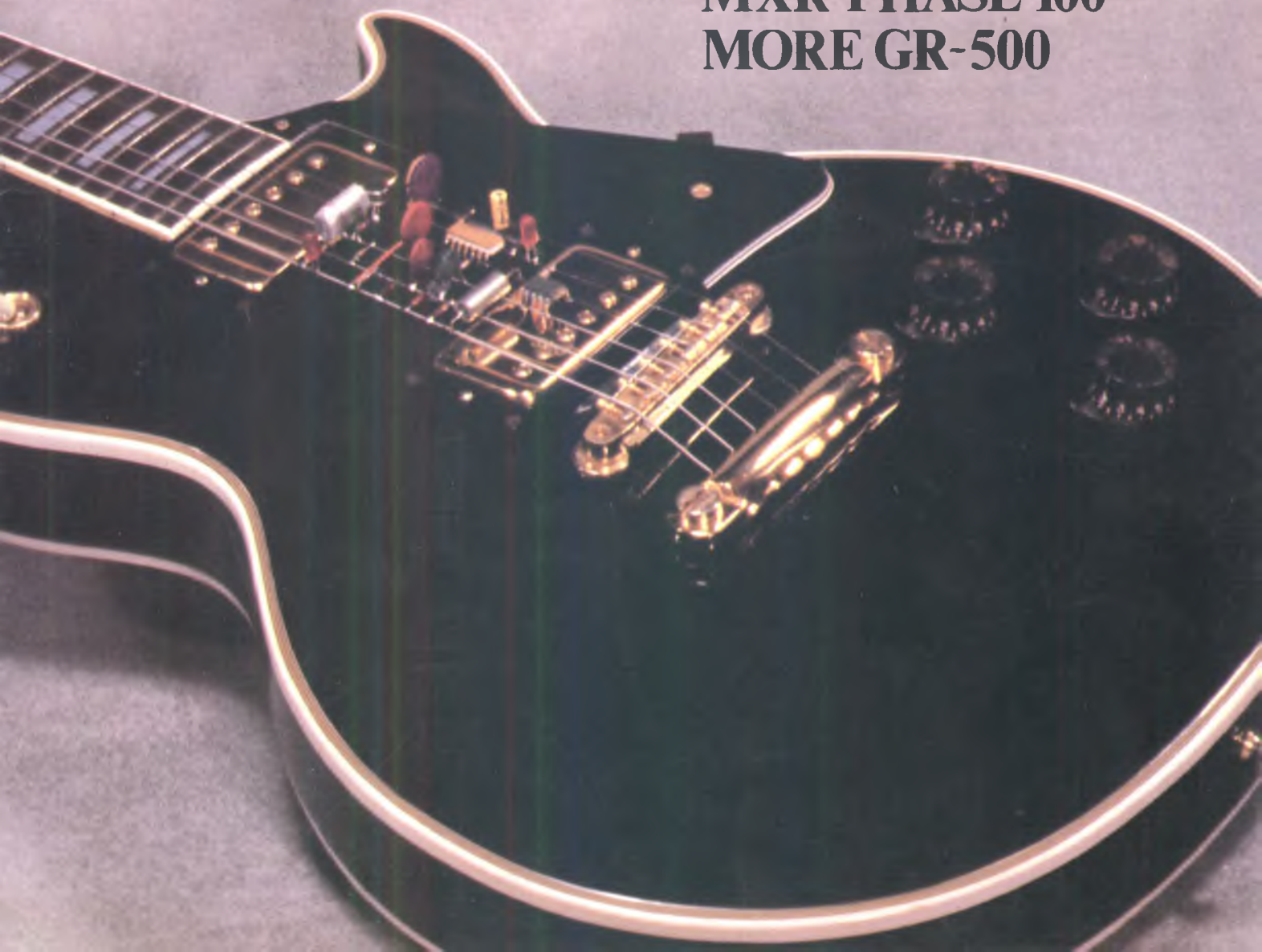

# THE ULTIMATE KEYBOARD



The Prophet-10 is *the* most complete keyboard instrument available today. The Prophet is a true polyphonic programmable synthesizer with 10 complete voices and 2 manuals. Each 5 voice keyboard has its own programmer allowing two completely different sounds to be played simultaneously. All ten voices can also be played from one keyboard program. Each voice has 2 voltage controlled oscillators, a mixer, a four pole low pass filter, two ADSR envelope generators, a final VCA and independent modulation capabilities.

The Prophet-10's total capabilities are too numerous to mention here, but some of the features include:

- \* Assignable voice modes (normal, single, double, alternate)
- \* Stereo and mono balanced and unbalanced outputs
- \* Pitch bend and modulation wheels
- \* Polyphonic modulation section
- \* Voice defeat system
- \* Two assignable & programmable control voltage pedals which can act on each manual independently
- \* Three-band programmable equalization
- \* Program increment footswitch
- \* Programmable volume control and a master volume control
- \* Octave transposition switches
- \* Upper & lower manual balance control
- \* A-440 reference tone

The Prophet-10 comes complete with a high quality flight case, two voltage pedals and two footswitches. It's now available; see your local dealer.

The Prophet-10 has an optional polyphonic sequencer that can be installed when the Prophet is ordered, or at a later date in the field. It fits completely within the main unit and operates on the lower manual. Various features of the sequencer are:

- \* Simplicity; just play normally & record exactly what you play.
- \* 2500 note capability, and 6 memory banks.
- \* *Built-in* micro-cassette deck for both sequence and program storage.
- \* Extensive editing & overdubbing facilities.
- \* Exact timing can be programmed, and an external clock can be used.
- \* Ability to change programs automatically in the sequence.
- \* Transpose facilities for instant pitch changes.

**Play the Prophet-10 today – It's your ULTIMATE KEYBOARD.**



# STAFF

**PUBLISHER**  
John S. Simonton, Jr.

**EDITOR**  
Craig Anderton

**MANAGING EDITOR**  
Linda Kay Brumfield

**ART DIRECTOR/  
PRODUCTION MGR.**  
Cynthia Rueb

**CIRCULATION**  
Ramona French  
Peggy Walker

**BOOKKEEPING**  
Helen Chalos

**PRINT PRODUCTION**

SEMCO Color Press

POLYPHONY (ISSN 0163-4534) is published bimonthly at 1020 W. Wilshire Blvd., Oklahoma City, OK 73116, by Polyphony Publishing Co. Entire contents copyright (c) 1981 by Polyphony Publishing Co. All rights reserved. No portion of this publication may be reproduced in any manner without written permission from the publisher. No patent liability is assumed with respect to the use of the information contained herein. Second Class postage is paid at Oklahoma City, OK 73125.

ADVERTISING rate card and deadline schedule is available upon request. Contact Linda Brumfield at (405) 842-5480.

DEALERS & DISTRIBUTORS bulk prices are available upon request. Contact Linda Brumfield at (405) 842-5480.

SUBSCRIPTION rates:  
American 1 year \$12.00  
          2 years \$22.00  
Foreign 1 year \$14.00  
          2 years \$26.00

We now accept MasterCard and Visa payment for subscriptions, back issues, and PolyMart items. Foreign payments must be by charge card, money order, or certified check in US funds drawn on a US bank.

BACK ISSUES are available at \$2.00 each ppd. Send SASE and request our 'Back Issue List' for a complete index of issues and their features, or see the back issue ad in this issue.

CHANGE OF ADDRESS notifications must include your former address and zip code, and any numbers from the mailing label, as well as your new address. When you move, be sure to notify your post office that you DO want second class and controlled circulation publications forwarded. This will save lost or returned issues. Polyphony is not responsible for replacement of lost or returned issues when we have not been supplied with change of address information.

TO POSTMASTER, send address changes to:

POLYPHONY  
PO Box 20305  
Oklahoma City, OK 73156  
Ph. (405) 842-5480

# CONTENTS

ISSN: 0163-4534

Volume 7, Number 1  
July/August 1981

## FEATURES

Build a \$5 Analog Programmer.....9	by Kirk Austin
Tube Tip.....12	by Gerald Michaud
Sample and Hold Composition Technique.....13	by Geoffrey Collier
Applied Synthesis: Marketing your Records....21	by Bill Rhodes
Fender Amp Mod.....22	by Lee Powell
Taking Control of Your MXR Phase 100.....25	by Matt Richards
More GR-500 Comments and Mods.....28	by Robert D. Loney
Modular Synthesizer Effects.....30	by Jim Aikin

## COLUMNS & REGULARS

Editor's Note.....4
Letters.....5
Reviews.....8
Current Events.....10
Practical Circuitry.....16
Patch.....29
Equipment Exchange.....34
Advertiser's Index.....29

On the Cover: photo by Vesta Copestakes

NATIONAL  
ASSOCIATION OF  
MUSIC MERCHANTS



July / August 1981

# EDITOR'S note

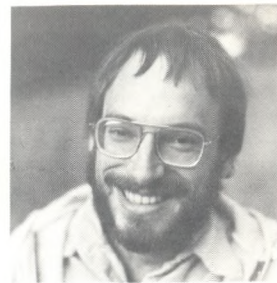

If you've made a record yourself and are trying to figure out how to market it, then read on...we've got some important news for you.

I've been hearing a lot of excellent self-produced albums these days; in fact, the quality of these recordings is starting to not just equal, but to surpass the quality of product put out by the major labels. Interestingly, I recently had a conversation with the leader of a Major Rock Group (hate to drop names, you know), and she was noting that the best drum sounds they were getting were not on the 24 track whiz-bang computerized board, but on the lead guitarist's Portastudio. Why? They had time to experiment, to get the sound just right, and all their Portastudio sessions took place under relaxed circumstances - a distinct contrast from the often nervous atmosphere that prevails in a recording studio, where you have to keep one eye on the tuning and the other eye on the budget.

When it comes to independent artists, take someone like Steve Tibbetts. His album was turned down by virtually every major label, so he marketed it himself. He's sold about 5000 copies of his 2nd album, "Yr" (which is excellent by any standards), and the sales show no signs of letting up.

Then there's the fellow who calls me up periodically and plays me selections from his album in progress over the phone. It's all synthesizer, all fresh, and again, up to a very high standard of quality.

These independent musicians would appear to have everything going for them: good studios, a good product, excellent music, and a degree of innovation that you're just not going to find on the radio. But they are lacking one thing: Distribution.

What brought this home to me was an album by Bill Rhodes, who also writes for Polyphony (see the article on marketing your own record in this issue). I had never heard of Bill Rhodes, but he had heard of me, so he sent me the album. The music was good, but that's not the point...the point is that his work would appeal to lots of people, but since not everybody is as visible as I am, most people will probably never hear about it.

I've played Steve Tibbetts' album for lots of people, and virtually everybody loves it. But, they would never have known about the album had I not played it for them first.

The problem is obvious: Who's going to buy an album from someone they've never heard of who lives halfway across the country? We've already attacked the problem from one direction, by hiring a reviewer who searches out as many independent releases as possible. And of course, you can always run an ad in Polyphony to promote your work, giving a brief description that will hopefully pique people's interest enough to induce them to send off some of their hard-earned cash for your record. That's

great for some people, but what if you can't afford an ad? What to do...

Well, we've created an alternate means of making music, and proved that we can make music that's as valid as anything coming out of the major labels. Next, we have to come up with an alternate means of distributing. I don't have the answer, but I have a proposal.

**The proposal is simple:** that Polymart put out a sampler tape or LP, containing a cut or a few minutes of music from various self-produced albums. This way, listeners can buy the sampler for a relatively low price, and decide what records they would like to hear more of.

Now, there are a few details to the proposal, namely:

- Polymart would NOT handle the individual records, only the sampler. Sources and prices for all music in the sampler would be printed on the album cover, or enclosed with the cassette.

- All copyrights would be held by the artist. We're not interested in publishing songs; we're interested in helping you get your music across. You would give us the right to use the excerpt of your choice (not to exceed, say, 4 minutes) on the sampler in return for the promotional advantage it would give you.

- Artists on the sampler would agree to receive no royalties for the use of their excerpt on the sampler. The object of the sampler is to get as much music as possible out to the public for the minimum possible price; paying royalties would force an increase in the price of the sampler that might prevent people from buying it. Realize, though, that Polymart would have to make some money off the sampler, both in order to cover expenses and, if possible, take out ads for the sampler in other magazines.

Interested? I thought you would be. Here's what to do.

Send a copy of your LP or EP to **SAMPLER, Polymart, PO Box 20305, Oklahoma City, OK 73156**, and indicate which selection you would like to have included on the sampler. We will then send you a form to sign giving us the right to use your material on the sampler, and also tell you when we expect to release the sampler. At the moment, I have no idea how many records we'll get; we may put out a cassette (which will probably cost less), or who knows, maybe there will be so much good stuff we'll have to release a double-album! In any event, we will not be able to return records. And, although we'll try to include as much material as possible on the sampler, we can't guarantee we'll use your music...but we'll do our best.

You readers are the wave of the future in music. We want to help in whatever way we can; the sampler is a first step.

Now it's your turn to participate.



# LETTERS

## VANISHING BOOKS

Where would we all be without our data books? The National Semiconductor Linear Data Book is the "bible" to analog speaking peoples everywhere. Why then can I not find a new one? A few years ago you could buy one right off the shelf at the worst of electronics stores. Now even at Radio Shack they only shake their heads and look at you funny. What gives?

Marc Briand  
Wichita, KS

Marc - What gives is that paper is expensive and getting more so, printing is expensive, and shipping books of that size is also expensive. Add to that the fact that the electronics industry, once considered recession proof, is starting to lay off some people, close down some facilities, and so on. In other words, money is tight and these companies have more on their minds than keeping hobbyists up to date on the parts they make. Of course, if you regularly buy \$40,000 worth of semiconductors, I'm sure you'll have no trouble getting all the books you need.

We've got plans at Polyphony for doing some data-oriented publications on parts, since no one else seems to be doing it. For example, Thomas Henry and I have collaborated on a booklet; and, we hope to put out a series covering the most popular electronic music parts. Of course, all of these grandiose plans are subject to time and money limitations, but if the first booklet goes over well, there will surely be more.

In the meantime, refine your badgering techniques, and see about scoring older manuals from companies when they get updated versions. Good luck - as one who has a hard time getting data books, I certainly sympathize with your plight.

--Craig

## AMS-100 INFO

I am very interested in the AMS-100 project you were running in DEVICE. Can I get photocopies of past articles? Did you finish it? Please tell me more.

I also know that DEVICE had lots of mods to various pieces of equipment. How can I get these?

Thank you very much for your attention.

Fernando Tepedino  
Sao Paulo, Brasil

Fernando - AMS stands for "Audio Modification System", and the AMS-100 is a modular system designed to process guitars, keyboards, tape tracks, or whatever. The AMS-100 was intended to be an experimental system, and therefore can never be "finished" since it is always possible to design new modules using new technology. I completed a basic AMS-100 system shortly before DEVICE folded; the only modules not presented in that magazine were a random control voltage generator and dual LFO/sample-and-hold module. I had planned on presenting these in Polyphony, however, they are both obsolete designs by now and can be done more cost-effectively. After I've re-designed them to reflect the current state of the art, they will be presented in Polyphony as construction projects. With those two modules and the modules already presented in DEVICE (back issues will be available from Polymart; see center spread), you can put together a pretty sophisticated sound modifications system. Eventually, I'd like to put out a publication containing all previous AMS-100 modules plus some newer ones as they come out. But this won't happen for a while; I'm really swamped right now, and am mostly concerned with building up Polyphony.

--Craig

## PC PATTERNS?

I have just become a subscriber to Polyphony (referred from DEVICE). I like this magazine, however, there are no circuit board patterns printed with your articles. Although I can build and use almost any project, I lack the expertise to design a circuit board from just a schematic. Is there any hope that the magazine will come to the aid of readers like me in the future? I think you would appeal to a much broader audience (very important to a magazine looking for solvency) by making this one change.

I also have a question about your mini-amp project from EPFM. Is there any way to incorporate an effects look into this design? This would help my teaching tremendously by allowing my students to learn to use effects.

Edgar A. Stanton  
Louisville, KY

Edgar - It takes me more time to generate PC board artwork than it does to develop and write an article; to build my prototypes, I use Vectorboard and a wire pencil. This is why my projects don't include circuit boards; I just

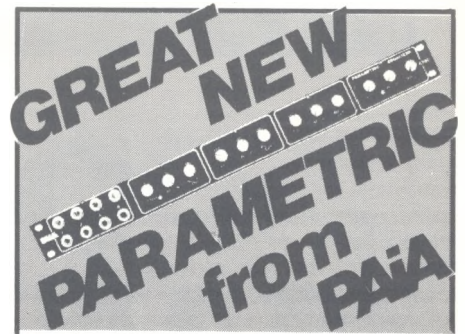

Whether notching out the feed-back howls in an unruly venue or sweetening the mix, this four stage PAIA Parametric designed by Craig Anderton is the most powerful and versatile tone control available. Each of the 4 independent section features infinitely variable control of frequency, resonance and boost/cut and the handy patch bay allows sections to be used separately or together in any combination. With PAIA's famous step-by-step instructions saving money is quick, easy and FUN.

Order TODAY and save even more by using the free shipping coupon below.

**PAIA Electronics, Inc.**  
Dept. 11y, 1020 W. Wilshire Blvd., Oklahoma City, OK 73116 (405) 843-9626

Send the 6760 Parametric Equalizer Kit. \$79.95 plus shipping for 3lbs. enclosed.

Send Free Catalog

name \_\_\_\_\_

address \_\_\_\_\_

city \_\_\_\_\_ state \_\_\_\_\_ zip \_\_\_\_\_

visa \_\_\_\_\_ mc \_\_\_\_\_ card no \_\_\_\_\_

**FREE SHIPPING WHEN ORDERED WITH THIS COUPON**

don't have enough time! With regards to articles from readers, we take what we can get and most articles do not include PC board artwork (you're not the only one who finds the process difficult). Also, PC artwork takes up a fair amount of space in the magazine, but only benefits those readers who actually build the project.

When possible, we're going to try to offer PC boards either through PAIA or from the readers themselves. In the case of the latter, there is the potential for creating problems, because there is no way we at Polyphony can monitor the quality control and business practices of those offering boards. We have one neat envelope generator project in the works where the reader has sent us a professional, well laid out board; he will be offering it to readers. Let's hope we get more of these in the future.

With respect to an effects loop, the place to add effects with a mini-amp is between the instrument and the input of the amp. There is no preamp/power amp combination in an amp chip, therefore, it is not possible to break that connection and insert a loop.

-- Craig

# OUR NEW MANUAL MIXER ENDS MANDATORY BUSSING.





**Now nobody but you determines the routes your signals travel.**

The Tascam System 20 isn't your common everyday mixer.

We pulled all the switches (their logic is fixed and limited) and put in patch points all along the signal path.

You make the connections, so practically anything you want is possible.

When the job at hand changes from basics to overdubs to remix, you just change the way the System 20 works.

All this flexibility brings incredible quality, too. Since you do your own routing, you can take shortcuts.

Bypassing circuits you don't need, getting really clean signals.

The System 20 also ends your nightmares about needing an absolute fortune for a console with this kind of flexibility and quality. Now you can make the music you dream about at a price you can afford.

The System 20 centers around the MM20 Master Module. It's nothing less than professional. Four line inputs and two XLR transformer-isolated microphone inputs. Six output busses ready to change with the job. If you need three or even four effects busses you can just patch them in.

Next, for truly flexible sound shaping, there's the four-channel PE20 Parametric Equalizer. Low frequency range is continuously variable with sweep-type setting from 60 Hz to 1.5 kHz. Mid-range sweep control from 1.5 kHz to 8 kHz. And the high frequency is fixed at 10 kHz. Boost and cut for all three is  $\pm 12$  dB.

Then there's the MU20 Meter Unit. Ready to patch anywhere you need it. Like buss outputs or tape playback. And with its four VU-type averaging meters and peak LED's, you have the best of both metering worlds.

Like the rest of the System 20, there's nothing common about the 4 x 4 EX20 Microphone Expander either. Four transformer-isolated inputs with twelve patch points.

Once you plug into the economy of our manual mixer, you can save even more

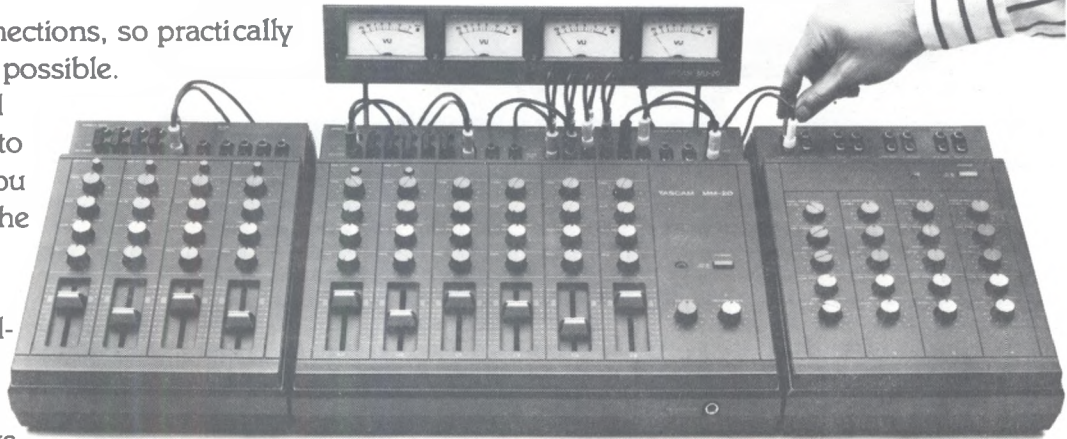

by hooking up with Tascam's two new economical compact recorder/reproducers. Both give you 15 ips on 7" reels for 22-1/2 minutes of quality recording time.

You save in the long run, too. Because the System 20's modular design adds yet another dimension of flexibility. It grows right along with you. So when you're ready for 8-track, you just add another Master Module instead of an expensive new mixer.

Visit your Tascam dealer for a demonstration. Then you'll see exactly how the System 20 opens up new avenues of creativity.

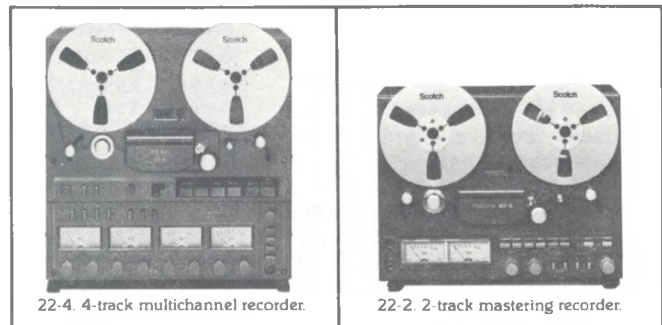

22-4. 4-track multichannel recorder.

22-2. 2-track mastering recorder.

**TASCAM** CREATIVE SERIES

TEAC Production Products

©1981 TEAC Corporation of America, 7733 Telegraph Road, Montebello, CA 90640





# re-view

by Robert Carlberg

Laurie Anderson **O Superman/Walk the Dog** (single; One Ten 005). It is the arrival of records like this which makes this job so much fun. Wacky and thoroughly delightful songs about mom, Dolly Parton, and 30 ft. high dogs using vocoded vocals, small wind ensemble, synthesizer and tape loops. This fruit of the trees planted in the electronic decade deserves to be heard by every music lover with a sense of humor.

Crutchfield's Dark Day **Exterminating Angel** (Lust/Unlust 229). Nothing dark about these upbeat little ditties built around LFO sixteenth notes. Very simple but effective.

ImpLOG **Holland Tunnel Dive/On B'Way** (e.p.; Lust/Unlust 231). Who would have thought a blender could take three solos over disco beat electronics? "On B'Way" really is the old Drifter's tune, sort of - lyrics are recited into a resonating filter, a poor man's vocoder.

Jody Harris/Robert Quine **Escape** (Lust/Unlust 236) Formless guitar improvisations over a rhythm box. Listener endurance tests.

Jeff and Jane Hudson **World Trade** (e.p.; Lust/Unlust 243). Kitschy non-vocals over rhythm box and minimal synthesizing. They sound bored.

Joy Division **Closer** (Fact 25). Take a real drummer who sounds like a drumbox, add monotone vocals and drone keyboards. Mix well and half-bake.

Happy the Man **Happy the Man** (Arista 4120); **Crafty Hands** (Arista 4191). Complex, heavily

produced works, combining the keyboard dominance of Genesis with the wide-ranging dynamics and time-changes of Egg or Hatfield. If these are the excesses against which New Wave rallies, too bad.

George Crumb **Makrokosmos Vol. I** (Nonesuch 71293); **Makrokosmos Vol. II** (Columbia Odyssey 34135). A long experimental piano piece, made tolerable - even pleasant - by a constant tension between non-standard playing techniques (directly on the strings, etc.) and brief snippets of normal tonal piano playing.

Other Music **Prime Numbers** (OMJ 14); Gamelan Son of Lion **Gamelan in the New World** (Folkways 31313). Two groups who explore the similarities between Steve Reich's phase music and traditional Javanese Gamelan music. Both write for self-built tuned percussion instruments.

Beakers/John Foster/Steve Fisk **Life Elsewhere** (e.p.; Mr. Brown 667). Gentle send-ups of the charming naivete of the '60s Love Generation. In particular, Fisk's "Woodstock" should be required listening for any remaining long-hairs.

David Keane **Lyra** (Music Gallery Editions 29). Process music for piano, double bass, voice and oscillator (one track each). Heavy on "exploring the tonalities" - some of which are fascinating.

Baird Hersey & The Year of the Ear **Lookin' For That Groove** (Arista 3004); Baird Hersey & The Year of the Ear **Have you Heard?** (Arista 3016); Baird Hersey & David Moss **Coessential** (Bent 2); Baird Her-

sey **Solo: ODO OP8 FX** (Bent 3). The Year of the Ear recordings are brassy big band jazz (7 horns and 4 percussionists) occasionally aided by Hersey's electric guitar and/or Avatar guitar synthesizer. David Moss, one of the Ear and also featured on Michael Gilbert's **The Call**, brings a whole roomful of percussion with him and nudges Hersey into some pretty wild guitar improvisations. **Solo** is guitar and guitar/Avatar solos over sequencer-triggered Oberheim chords - a nice blend of composed themes with stately ad libs.

Michael Waisvisz **Crackle** (Claxon 77.1). Waisvisz coaxes squeaks and rumbles out of a small, self-built synthesizer that sounds like it's about to blow up. What he lacks in polish he makes up for in innovation.

Steven Feigenbaum & Tom Scott **Things are More Like They Are Now Than They Ever Were Before** (Random Radar 007). Scott is reedman with the Muffins, a fine neo-Canterbury/Henry Cow-ish group from Maryland. Feigenbaum is an all-around guitarist and the founder of Wayside Music. Together, on a variety of instruments and in a number of styles, they sound like a much bigger ensemble of consummate musicians, in the best tradition of recent British jazz.

Keith Slane **Star Captain** (Aural Explorer 5011); **Quantum Jump/Home** (single; Akustic 12271). Science fiction and electronic music are inexorably mixed in some people's minds. Although he writes some very pleasant synthesizer rock tunes, Slane feels compelled to doll them up with R2D2 sounds, continued on page.....12



# Build a \$5 ANALOG PROGRAMMER

by Kirk Austin

After building a few voltage controlled signal processing devices optimized for maximum versatility, I unexpectedly found myself using a few "pet sounds" over and over again rather than taking full advantage of the various controls. With my analog delay, for example, I use automatic-double-tracking, flanging, and slap-back echo regularly, and I usually set up the controls the same way every time I use these effects. I began to realize that some type of programmer would save me a lot of time, but couldn't justify a complex digital design when all I needed were a few preset analog voltages. So, I came up with the simple - but effective - analog programmer shown in figure 1. It's very easy to build, draws virtually no power, and generates four different "programs" of two control voltages each (with two toggle switches selecting the appropriate program). For those who suffer from digiphobia (an unexplained fear of digital circuitry), this is an easy way to come up with a computer-less programmer.

**How it works.** A 4052 IC is the electronic equivalent of a DP4T switch. Program switches S1 and S2 specify the four "positions" of this "switch" (see Table 1 for how the settings of S1 and S2 correspond to which trim pots connect to the control voltage outputs). You simply adjust these trim pots the way you would adjust a pair of normal panel controls; in fact, one of the programs could select the front panel controls instead of the trim pots, so that you have the choice of three pre-programmed settings along with normal front panel operation. What could be simpler? An interesting bonus of using an analog design is that it never forgets (as some digital programmers have been known to do), and it can also program audio or sub-audio signal levels as well as DC voltages. (However, these signals must not go more than 0.7V below ground in order to work right with the 4052; you could use a bipolar

+7.5V supply to handle bipolar audio signals, but then positive control voltages would be limited to +7.5V.)

**Construction and modifications.** Construction consists mainly of wiring the trimmers to the 4052 chip. I used some miniature trim pots available from Digi-Key, to minimize expense and circuit board size. I strongly advise using a socket for the 4052 (and any other chips you use, for that matter) as it is subject to damage from static charges. Using sockets also allows you to salvage chips from obsolete circuits without having to desolder them; in fact, without fail, every circuit that I have built that didn't use sockets has come back to haunt me in one way or another.

You could take this whole idea further and use 4051s (SP8T analog switches) with three program switches to get 8 presets instead of 4. Once you get past a certain level of complexity, though, a digital approach is more reasonable.

By the way, even if you don't build this project I suggest that you get some of these chips and experiment with them. There are so many things in musical electronics that can be done with analog gates. I have used them to select between different effects loops, and have also wired up a circuit to allow me to switch between different master volume levels on my Marshall amp. If you start playing around with some of these chips, I'm sure that you'll come up with ideas of your own. In any event, happy programming.

Table 1

S1 position	S2 position	connects the following pins to CV1 and CV2
gnd	gnd	1 & 12
gnd	(+)	5 & 14
(+)	gnd	2 & 15
(+)	(+)	4 & 11

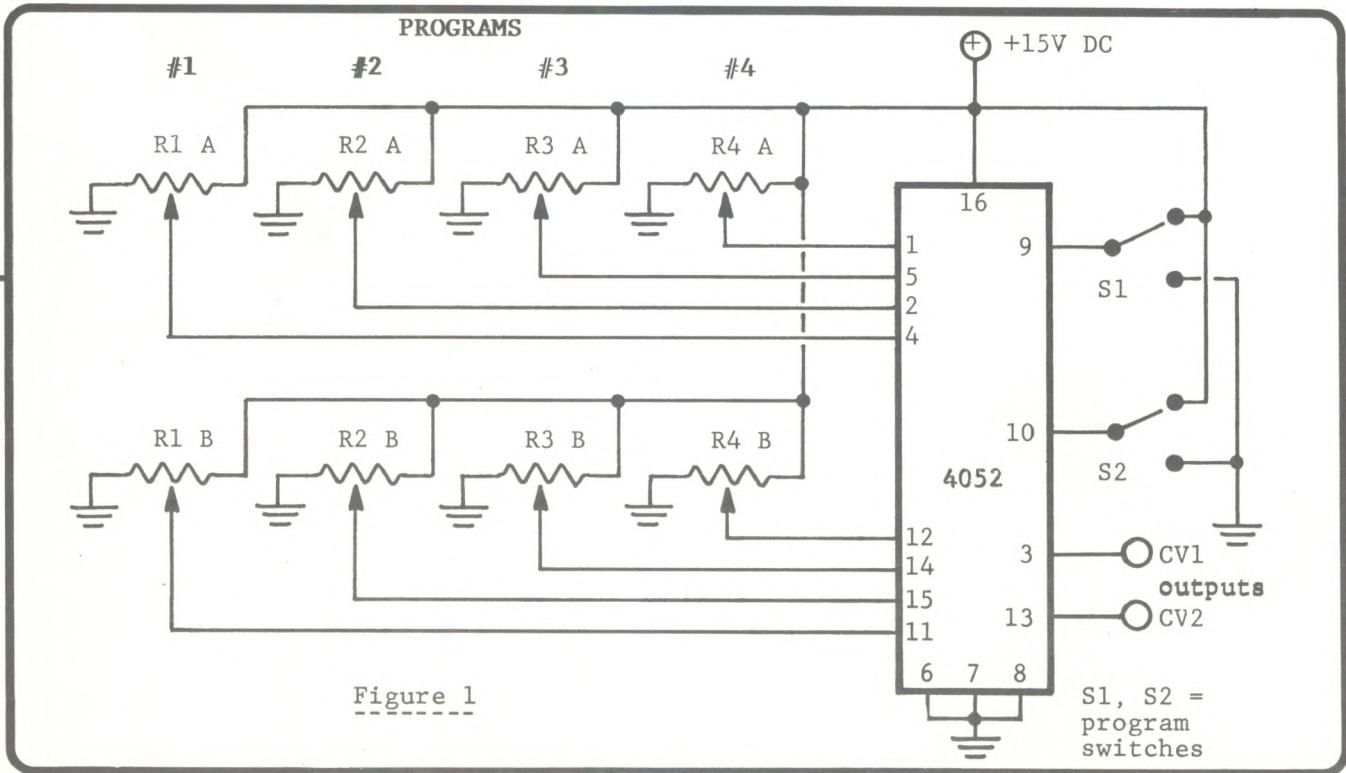

# CURRENT EVENTS

*'Tell Them You Saw It In Polyphony'*

**New Recording Techniques/Signal Processor to be Unveiled at AES.** On October 31 at 7 PM, at the Waldorf-Astoria in New York City, Craig Anderton will present a paper on Synchro-Sonic recording techniques at the 70th Audio Engineering Society Convention. This process optionally ties all signal processors, instruments, and electronic events (vibrato, LFO sweeps, sample-and-hold, etc.) into one rhythmic framework, traceable to one master clock. Many recorded examples, mostly drawn from Craig's upcoming solo album, will demonstrate the considerable potential of Synchro-Sonic music and recording techniques.

Also, Harald Bode, the subject of an upcoming interview in Polyphony by Jay Lee, will be presenting a paper entitled "Psycho-Acoustical Aspects and Musical Applications of an Infinite Phaser". The presentation will include an historical perspective on this type of signal processor, as well as recorded compositions that showcase the process of infinite phasing.

**16 Track Studio Console.** TEAC (7733 Telegraph Road, Montebello, CA 90640) has announced the M-16, a mixer with 16 or 24 input positions. Features include 8 main program mixing busses with submaster faders, 8 main board outputs, 2 independent stereo mixing busses, 4 aux mixing busses, 16 meters, 4 band/8 knob bypassable parametric equalizers, and 3 filters (two high-pass, one low-pass). The M-16 lists for \$12,900.



**Shhhhhh.** dbx is introducing a two-chip set designed to replace the discrete components in a dbx noise reduction system. For further technical and licensing information, contact dbx at 71 Chapel St., Newton, MA 02195.

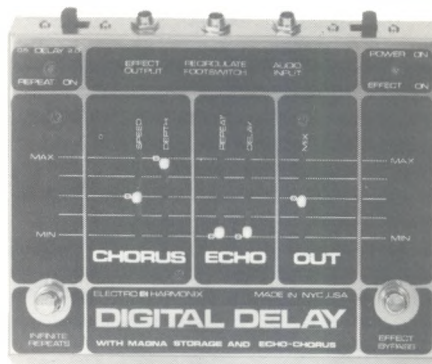

**Electro-Harmonix Digital Delay Makes Debut.** E-H's new device gives you up to two seconds of delay; you may also record up to two seconds of music in digital memory and play it back continuously while you play along with it. Claimed specs include delay time, 8 ms to 2 s; high-end frequency response, 12 KHz +3 dB up to 1/2 second, 3.5 KHz +3 dB from 1/2 second up to 2 sec; S/N ratio 85 dB; and distortion, less than 5%. The unit also includes chorus and vibrato capabilities.



Also from E-H is the **Graphic Fuzz**, which includes a built-in graphic equalizer and preserves the dynamics of your playing. Craig will be reviewing this device in an upcoming issue of *Modern Recording & Music* magazine.

**New from Roland.** The MC-4, an updated version of the MC-8, allows programming of up to four pairs of voices from either a synthesizer keyboard and/or the MC-4's calculator style keyboard. Performances can include programmed pitch, rhythm, programmed dynamics, programmed tempo, and more. Tape sync is provided for building multi-track compositions; tape interface allows for storage of composition/performance data. The MC-4 with 48k of memory, which allows up to 11,500 notes of com-

position/performance at one time, lists for \$3295.

**New Music from CRI.** Composers Recordings, Inc. (170 West 74 St., New York, NY 10023) has released three new albums: Music of Warren Benson (CRI SD 433), Percussion Music by Read and MacGregor (CRI SD 444), and New Music From Sweden (Louisville LS 773).



**Marshall from Unicord.** Unicord (89 Frost St., Westbury, NY 11590) has announced the introduction of the Jim Marshall Signature Series Amplifiers. Models include the basic Marshall 50 and 100 Watt lead amplifiers, available in both standard format and with Master Volume, as well as the new model 2000 200 Watt lead and 2001 300 Watt bass units. The latter models utilize a two channel design with channel switching facilities, and FX loop for all channels.



# CURRENT EVENTS

*" Please Plug Polyphony "*

**PAIA Manuals Sound Off.** PAIA (1020 W. Wilshire Blvd., Oklahoma City, OK 73116) now includes demonstration cassettes with the instruction manuals for their most popular musical instruments. Of particular interest to Polyphony readers will be the fact that the

demonstrations of PAIA's Organtua, Proteus I and the Drum were produced by Craig Anderton. As an added bonus, the Proteus I demo includes five new instrumental compositions from Craig commissioned specifically for this tape by PAIA Electronics.



**Korg LP-10 Piano.** The LP-10 offers mixable acoustic piano, electric piano, and clav timbres in a portable, 22 lb. package. Features include 5 octave key-

board, chorus effect, key transpose switch, variable decay characteristics, and a built-in 6 band graphic equalizer. Korg, division of Unicord, 89 Frost St., Westbury, NY 11590.

**Synthesis Information Service in Great Britain.** Electronic Computer Synthesizer Sound (The Sound House, PO Box 37b, East Molesey, Surrey KT8 9JB, UK) is a center for the research, development, and promotion of electronic synthesizer sound. Services include: information service and library, list of recordings and publications, distribution center, more.

**Music for Health.** Those who are interested in music as a healing force should be aware of Halpern Sounds (620 Taylor Way #14, Belmont, CA 94002). Steven Halpern has recorded numerous albums designed to "tune" the human body and promote mental/physical/psychic well-being. A book explaining Halpern's philosophy, "Tuning the Human Instrument", is also available. Write to the address above for brochure.

## SOMEDAY YOU'LL NEED A COMPUTER.

### LUCKILY, YOU ALREADY KNOW THE MOST IMPORTANT THING TO LOOK FOR...

Synthesizer players know that for the ultimate in versatility, modular synthesizers are the only way to go. Only with a modular system can you choose the components you like, simplify maintenance, and expand the system as your needs require - or as your finances permit.

Computers are no different: unlike limited, all-in-one computers that may or may not have the options and software you need, computer systems composed of components that adhere to the S-100 bus standard (as defined by the prestigious IEEE) are modular, expandable, easily upgradable machines that don't become obsolete as technology progresses.

For demanding industrial, scientific, and commercial applications, **CompuPro's** broad line of advanced S-100 system components offers an unbeatable combination of innovative engineering, high performance, and cost-effectiveness. And, unlike some companies that introduce a computer one year and forget about it the next, we've been making quality S-100 components for over 6 years.

When a computer becomes a necessity in your life, make the right choice: system components from **CompuPro**. For more information, visit your authorized **CompuPro** sales center (call 415-562-0636 for the one nearest you), or write us direct.

**CompuPro**™

OAKLAND AIRPORT, CA 94614

division

(415) 562-0636

**GODBOUT**  
ELECTRONICS



# TUBE ... TIP

by Gerard Michaud

We can substitute 6CA7 tubes in amps originally fitted for 6L6s; however, the price paid is some crossover distortion. To cure this, simply feed a sine wave generator into the input, and adjust the bias control (like the one on Fender amps found just beside the choke and power transformer) until the crossover distortion disappears. The advantage of using 6CA7s is a somewhat crisper, more defined treble, as well as bass that's a little bit tighter. You can also substitute 6550s with no bias modifications, but you must then add a fan for cooling. 6550s last longer than 6L6s due to their special construction, and do not get microphonic. C

# re-view

continued from page.....8

laser pistol zaps, and even Star Wars cantina sequence. The single presents two of the better tunes, sans silliness.

Ilham Mimaroglu **Tract** (Folkways 33441). Subtitled "Agitprop Music" for "agitation-propaganda", **Tract** was composed in response to political upheaval in Mimaroglu's native Turkey. Radio fragments, pieces of poems and female voice are collaged over piano and Columbia-Princeton synthesizer. There are many outside references.

Craig Kupka (and others) **Clouds** (Folkways 6195). "Non-stress inducing" meditation music for relaxation/blocking out unpleasant distractions/concentrating on inner feelings. Very slow modal improvs for vibes, Rhodes, celeste, guitar and synthesizer - musical Valium. Yawn.

Gianni Safred **Futuribile** (Folkways 6253). I'd never heard of jazz pianist Safred before - now I know why. Schlocky swept-filter disco-beat synthesizer with titles like "Disco Satellite", "Robot Party", "Jazz Computer", etc. Eminently forgettable.

Phillip Perkins **Tool's Paint/Reading the Mail** (single; Fun 1001). Several layers of hollow electronic bonging (created by slowing down the click of a whistle) b/w the cacophony of CB radio over a slow organ processional. Personal visions you won't hear on the radio.

Barton McLean (and others) **Electronic Music from the Outside In** (Folkways 6050). Narrated instructional 2-LP set on tape-music technique. Just like it says in the album notes: "...a foreknowledge of electronic music is not at all necessary. On the other hand, anyone who has anything to do with electronic music can, perhaps, benefit from these insights..."

Randall McClellan **Genesis/Interruptions** (Opus One 24). McClellan is the direction of the E.M. studio at Hampshire College, Amherst. He could take a lesson from his student Michael Gilbert in coming back to earth; both pieces are typical academic oscillator exercises. They are ten years old, though.

Lew Corelis/Jack Schrage: Music Werks **Songs You've Never Heard Before** (River Music Werks). Electronic keyboards (mostly Poly- and minimoog) create sound textures which only rarely break out into "songs". Unfortunately, for me most of it is not thick enough to prosper as textures, and too abstract to function as songs - an uncomfortable no-man's land.

Emerald Web **Dragon Wings and Wizard Tales** (Star-gate 4230). Emerald Web is flutists/synthesists Bob Stohl and Kat Epple, both steeped in mysticism and evidently much music - everything from TONTO to Stravinsky to King Crimson. Delicate flute solos, mournful pitch-bends and occasionally Ms. Epple's breathy voice over string synthesizer chords make up the most of it. The record is almost too broad to have a personality. C

## BY PROFESSIONAL DEMAND

DDC OFFERS FREE ADVICE, PERSONAL SERVICE AND ONE-DAY SHIPPING OF THE FINEST MUSIC AND SOUND EQUIPMENT AVAILABLE ANYWHERE:

**CROWN** Traynor  
**EV** KORG polyfusion  
**KELSEY** Colortone  
**TEAC** StreetTUNER  
**MXR** RMI  
**LP** Zildjian  
**DiMarzio**  
**TAPCO** REMO  
**CRUMAR** Oberheim  
**SHURE** whirlwind  
**prophet** DMI  
**ROSS**  
**KRAMER** OSC  
**ASHLY**  
**ARP** intersound

PLEASE CALL OR WRITE FOR PRICES & ORDERING INFORMATION - YOU'LL BE GLAD YOU DID!

**DDC** DICKSTEIN DISTRIBUTING COMPANY  
 1120 QUINCY PPY-SCRANTON, PA 18510  
 PHONE ORDERS WELCOME (717) 344 7469



# SAMPLE & HOLD COMPOSITION TECHNIQUE

by Geoffrey Collier

When first exposed to the sample and hold (S/H) module in a college synthesizer course, I was totally thrilled - but also totally confused. Subsequent investigation cleared up my confusion and exposed me to the many sounds of which an S/H is capable. In this article, we'll cover some of the many talents of this versatile module.

input results in a series of apparently random output voltages. However, this randomness soon becomes boring; so, I started experimenting with sampling repetitious (periodic) waveforms. The results obtained by sampling a sawtooth wave were most interesting, so we'll discuss this subject in depth. In order to best hear the results of these experi-

ments, I sent the S/H output to a VCO.

confused by a constantly changing clock rate.

We can begin by sampling a very low frequency sawtooth, which yields a long, ascending scale-like pattern that periodically jumps to the beginning and starts again (see figure 1). Because of the virtual impossibility of getting the clock rate to be an exact divisor of the period of the wave, the odds are very small of generating a pattern that will repeat itself exactly. Because there is a slight amount of overlap at the crest of each wave, the Initial Clock Period (my term for the first sample of each wave and therefore the lowest note in each scale) will constantly shift downward towards the onset of the wave, causing each scale to be lower than the preceding one. Finally, what would have been the ICP of the wave misses the beginning of that wave altogether, lands on the tail end of the preceding wave, and gives that wave an extra note. As a result, every few measures (reverting to musical terminology), there will be a bar with an extra beat, creating such interesting polyrhythms as 7 + 7 + 7 + 8. We can control how often the bar with the extra beat occurs by controlling the rate of descent of the ICPs (a function of the wave frequency); the slower the descent, the less often the longer bar occurs. This makes it possible for us to consciously generate a number of different polyrhythms. Once again, however, because the mathematical relationship between the clock rate and the wave period is not exact, a pattern will not maintain itself indefinitely. We can overcome this problem by taping a segment of the pattern and then getting it to repeat itself with splicing techniques or through the use of a tape loop.

As we increase the frequency of the wave, the descent of the ICPs slows, and they come to a standstill, causing the scale to

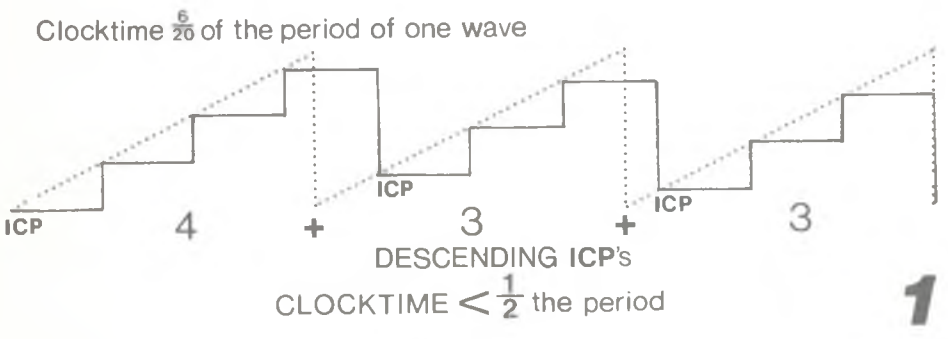

**Basics of Sample and Hold.** Each of the S/H's two inputs and one output introduces a variable worth exploring. The output, which takes the form of a varying control voltage, may be fed to voltage controlled modules "as is" or processed by control voltage processors. Traditionally, one of the inputs samples the voltage of a waveform (Control Voltage In) at a rate specified by the clock rate present at the other input (External Clock In, Sample In, or sometimes Strobe In). For now, let's investigate some of the waveforms suitable for sampling by the S/H.

The easiest way to understand an S/H is to think of it as taking periodic snapshots of the waveform being sampled, with each still shot corresponding to a discrete voltage level. This voltage level becomes the module's output.

On my ARP 2600, as on many synthesizers, the sampling source input is normalized to the white noise generator. Sampling this

ments, I sent the S/H output to a VCO.

**Experimenting with the Control Voltage Input.** The sampling process is somewhat reminiscent of the story about the blind men and the elephant - we have to get lots of shots of a single wave, or we'll end up with a rather contorted image of what the wave must look like. We can increase the number of shots by coaxing our "photographer" into working faster (increasing the clock rate), or by slowing down the wave in order to keep pace with our reluctant photographer (decreasing the frequency of the waveform being sampled). Since either option will yield the same result, we can perform our experiment by playing with only one of the two variables. I chose to work with the frequency of the wave, rather than changing the clock speed, because this enabled me to concentrate on the different patterns available without being

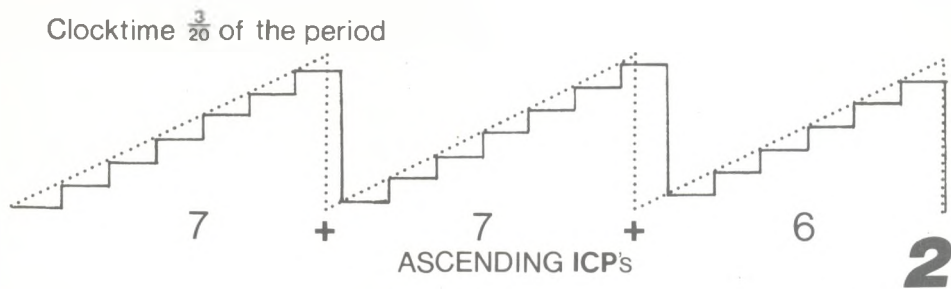

repeat itself. The ICPs then begin to ascend as we can see on figure 2. During the ascent, the odd bar now contains not one extra, but one fewer, note. As the frequency increases the short bar occurs more and more often, until the two bars alternate with each other (say a 7 and a 6). If we push the frequency a little higher, the 6 will become a more common rhythm, and at the same time the ICPs will start to descend. We are now back where we started, except that instead of alternating 8s and 7s, we alternate 7s and a 6. As we continue to increase the frequency, this whole cycle keeps repeating, going through 6 + 5, 5 + 4, until we get to 2 + 1, as illustrated in figure 3. Push this one step further, and each wave is sampled only once.

starts to ascend, individual pitches can be heard and we have an ascending scale (see figure 5). We have now come full circle, and we are back where we started - except that the samples are occurring on successive waves rather than different portions of a single wave (which makes no practical difference). This entire cycle

occurs through smaller and smaller increments of the tuning control. This is because the tuning control increases the oscillator's frequency exponentially, but the clock looks at the wave from a linear point of view - it sees an increase of frequency from 100 to 200 Hz as being the same as an increase from 1000 to 1100 Hz.

**Exploring the External Clock Input.** By using the square wave of a VCO in its low frequency range we can now voltage control the sampling rate. Note that changing the pulse width of the sampling wave will make no difference to the S/H because the S/H responds only to the leading edge of the wave (other S/H designs may not follow this convention, incidentally). We can experiment with a variety of control voltages (CV) to the clock wave. We can, for

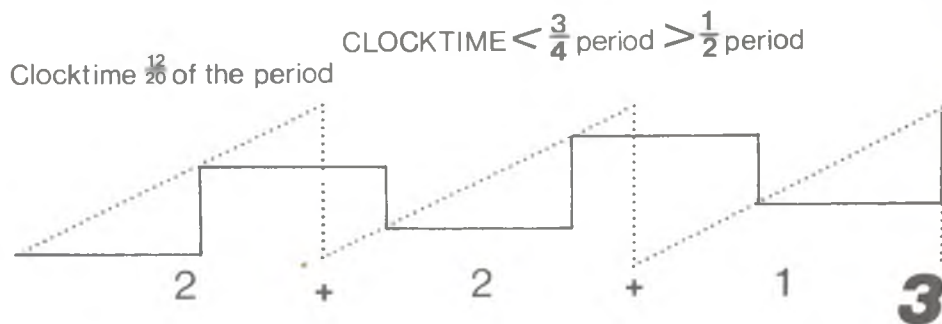

keeps repeating itself as the frequency of the sampled wave increases, even as this goes into the auditory range. The only difference is that the cycle oc-

example, get the sampling rate to be proportional to the pitch of the melody by using the CV from the keyboard or other controller, directly or through an inverter.

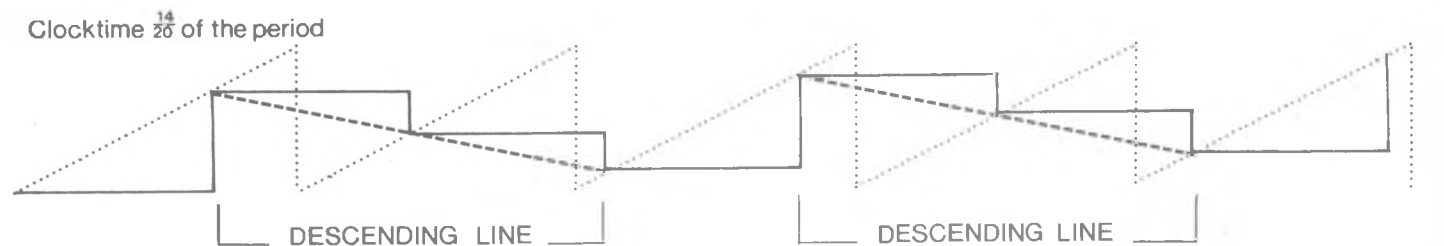

CLOCKTIME APPROACHES PERIOD

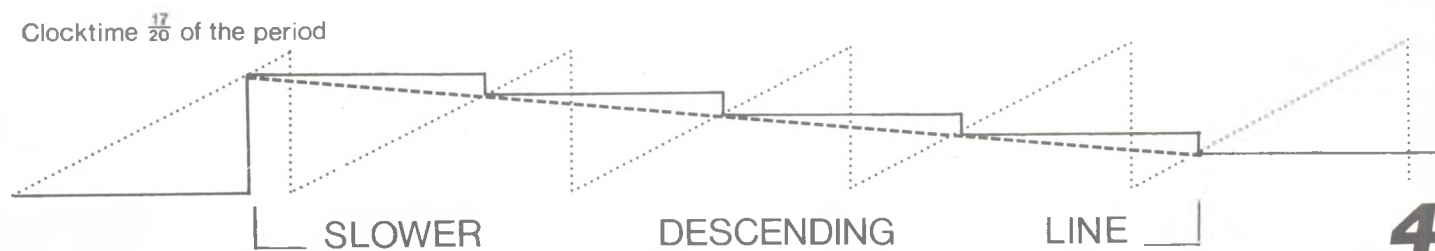



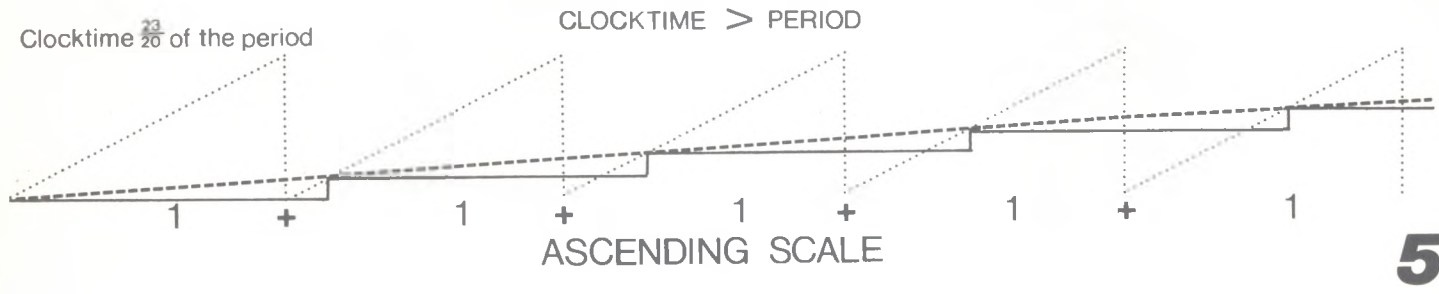

Or, we can use an ADSR envelope generator triggered by the gate or trigger voltage. Every time a new note is hit, the sampling rate will speed up and slow down in complex patterns determined by the ADSR control settings. Another alternative is to create a feedback loop by sending the S/H output back to an LFO feeding the clock. This will cause the high CVs to rush by quickly and the slow ones to take their time (again, this is an invertible process by adding an inverter).

There are other interesting clock possibilities. If we use the controller trigger voltage, we can, for instance, get a different timbre with every note we play. We can also use any external source such as an instrument or tape. The clock input of many S/H modules will respond to any sharply rising amplitude change; when there are rapid amplitude changes, the clock gets confused and a strange warbling results. It would be interesting to then feed the tape through a filter which is being controlled by the S/H output, causing timbral changes on the program material to be a function of amplitude changes.

A good tape technique is to record the clock, allowing us to overdub a number of rhythmic layers in sync with each other (editor's note: see Tom Henry's column in this issue for additional information on the tape/sync track interface). The clock can be heard as an audible click on the tape, although it is at twice the clocking frequency because the S/H responds to the leading edge of the wave only.

**Output Considerations.** I'd like to close this article with a few comments on the final link in the S/H chain, namely, the choice

of which module receives the S/H output. Unusual patches can be created by sending this output to the VCA and some of the more esoteric functions available on your system, such as voltage controlled resonance (VCQ) or voltage controlled reverb. However, I will focus on the more common and perhaps more useful choice of the VCO and VCF. One of the most basic usages is to send the S/H CV to the filter, thereby creating a rhythm against which you can play fixed melodies or improvise. High resonance filter settings provide the most dramatic emphasis of the rhythm, if also the most hackneyed. The contrast between beats can be heightened if you have VCQ and send the CV to this input as well as to the cutoff point.

More dramatic rhythms come from using the VCOs, although this eliminates the possibility of creating controllable melodies. I find that the best effects come from tuning the oscillators to an interval and maintaining this interval by putting the CV into the 1V/octave inputs of the oscillators. I like the sound of a few fifths or fourths of the same waveform piled on top of each other, all moving in parallel motion.

One problem that I encountered is that if the CV is going to several different modules, the effects achieved will always work in parallel because a given voltage change will cause a predictable change in each module - for example, a high note will always occur at the same time as an open filter. We can improve the situation by processing the CV before it goes to the one of the modules. In addition to inverting it, we can put it through a lag processor (slew limiter) which will give the pleasant effect of rounding off the sharp edges of each control

voltage transition. However, the only true solution would be to use two different S/H units that are both being triggered by the same clock, which would randomize the audio outputs of the two modules yet preserve the same rhythmic relationship.

Many other possibilities remain to be investigated, such as mixing waves before and after sampling them, or mixing the S/H output with other CVs before sending it out. I hope, however, that I have pointed the way towards a few avenues for further experimentation. **C**

★ ☆ ★ ☆ ★ ☆ ★ ☆ ★ ☆ ★ ☆ ★ ☆ ★ ☆

TL061CP .....95	PGS- Your authorized hobby distributor for SOLID STATE MICRO-TECHNOLOGY. High Quality, Inexpensive I.C's for Audio and Electronic Music applications.
TL062CP .....1.55	
TL064CN .....2.45	
TL071CP .....80	
TL072CP .....1.35	
TL074CN .....2.25	
NE555P .....39	
NE570N .....3.75	
NE571N .....2.85	
NE572N .....5.30	
UA741CP .....29	
RC1556NB .....1.48	
MC1556C* .....1.48	
CA3080E .....1.00	
CA3280C .....1.98	
XR4136CP .....1.10	
XR4739CP .....1.30	
MK50240N .....5.47	
SN76477N .....2.48	
* T099 Can	

<b>VCO's</b>	<b>VCF's</b>
SSM2030 .....7.50	SSM2040 .....7.50
SSM2033 .....10.00	SSM2044 .....5.75
<b>VCA's</b>	<b>ADSR's</b>
SSM2000 .....7.50	SSM2050 .....7.50
SSM2010 .....7.50	SSM2055 .....6.50
SSM2020 .....7.50	SSM2056 .....5.75

---

**Analog Delay I.C's**

SAD-1024A.....21.00  
SAD-4096.....36.00

---

We also carry resistors, jacks, plugs, and More.  
Write or call to be placed on our mailing list and receive our free flyer!

---

**SATISFACTION GUARANTEED!**

TERMS: No minimum on check or money orders. If less than \$10 add .75 processing charge. \$10 Minimum on charge orders (MasterCard and VISA). Please supply card no., expiration date, and interbank no. (MasterCard) Sorry, we do not accept COD's. Indiana residents add 4% sales tax.  
SHIPPING & Handling: \$1.00 plus 5% of purchase.  
NOTE: Prices and availability subject to change without notice. Not responsible for typos. We reserve the right to substitute manufacturers. (Due to back orders, etc)

**PGS ELECTRONICS**

74 Hr. Order/Message Phone      P.O. BOX 735  
812 894-2839      TERRE HAUTE, IN 47808



# TRICKS WITH THE SN76477

## PART 2

THOMAS HENRY

Last time we talked about how to find new outputs on the SN76477. In this installment, let's switch gears and talk a little about how to get more sounds from the noise source.

**SN76477 noise source background.** The white noise source in this chip is not the back-biased transistor you might be familiar with, but a binary pseudo-random noise generator. I don't want to get too heavily into the theory of this (see Don Lancaster's *TTL Cookbook*, Howard W. Sams, 1974, pp 277-283 for a good treatment), but all we really need to know is that the noise source is basically a shift register, with various bits moving down the register at a rate determined by a master clock. This clock can be either internal or external to the chip.

Let's consider an internal clock circuit first. Normally the resistor connected from pin 4 to ground sets the clock rate, and that's that. However, we could just as easily replace the resistor with a

transistor (see figure 5). In this configuration the transistor acts like a throttle, and determines the current flow through pin 4, hence varying the clock rate.

Before getting too heavily entrenched in details, I suppose that I should say something about *why* we want to change the clock rate. The best answer I can give is "try it, you'll like it!". The sound is an incredible swooshing noise, and is very similar to phasing or flanging. The noise takes on a new tonality, and sweeping the clock changes the spectra in an eerie and dramatic manner.

**White noise percussive voice.** The circuit in figure 5 is specially adapted for a percussive voice, with the noise amplitude being controlled by the envelope generator and VCA. In addition, the envelope is tapped off of pin 8 and applied to the base of the transistor. The result is a voice which sweeps as the envelope dies away.

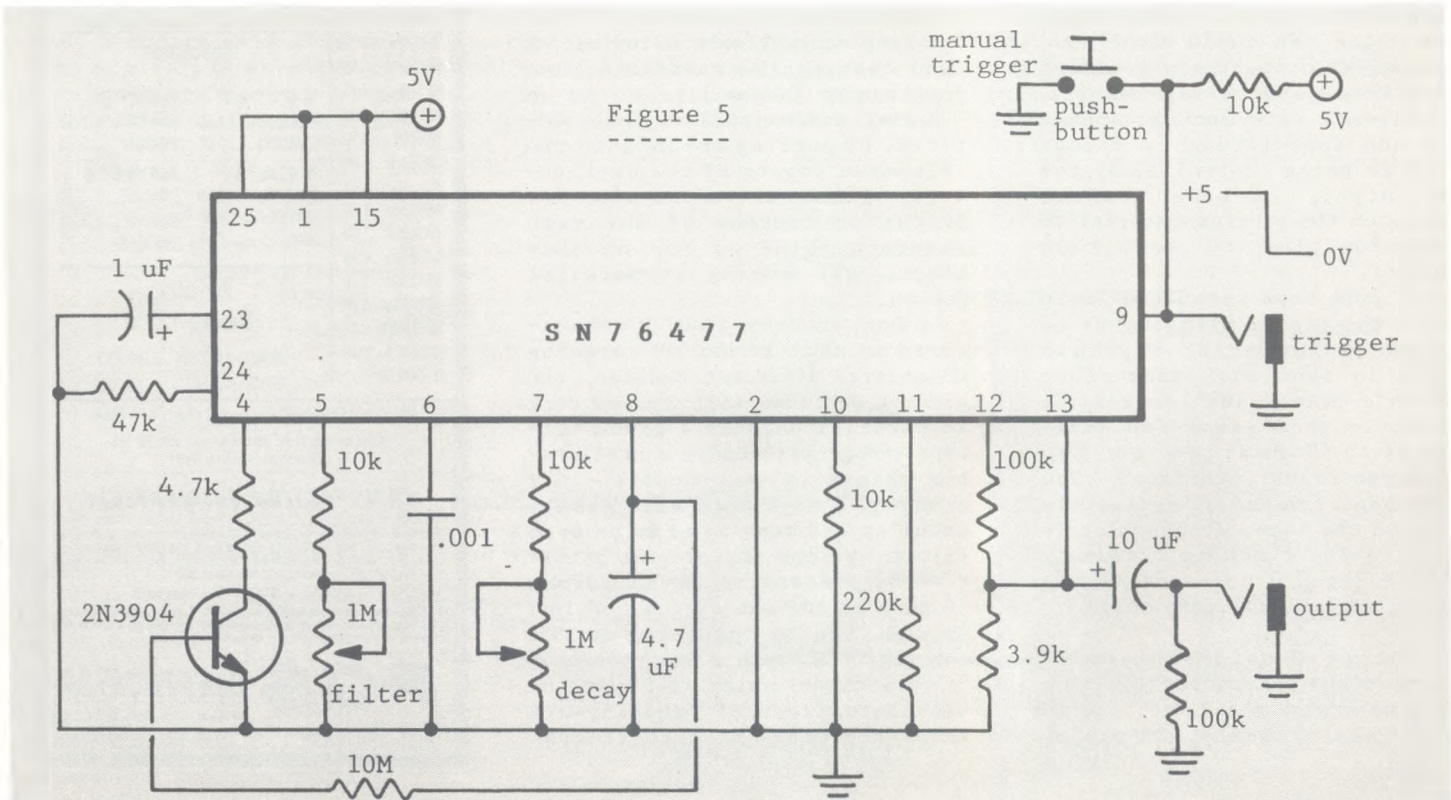



You will also note that the envelope is tapped via a 10 Meg resistor. The reason for such a large value is to avoid loading down the envelope generator capacitor. We could have buffered this voltage first using something like an op amp, but the loading caused by the 10M resistor is negligible, and is certainly cost-effective in this situation. Since the Beta (or DC current gain) of transistors varies from one unit to another, it may be that 10M is too large to allow the particular transistor you pick to turn on sufficiently. Feel free to experiment with other values; any value from 1M to 10M is permissible, but don't drop below 1M or excessive collector current may flow through pin 4 of the SN76477.

Before leaving figure 5, you should be aware that this would make a nice modification to the Percussive Noise Voice (John Bla-

its sweep range; when you need lots of sweep, try the circuit in figure 6.

Here we avoid the internal noise clock completely, and use an external clock instead. Actually, the "external" clock is really internal to the chip, being the VCO. This is a good way to save parts, space, and wiring hassles. However, if you were planning on using the VCO for something else, you could always clock the noise with virtually any other type of square wave oscillator.

Let's analyze the circuit; consider the VCO first. R9 and a capacitor selected by S1 (C2, C3, or C4) set the basic VCO frequency. A control voltage applied to J1 is summed through IC2 and applied to the control voltage input of the VCO, which sweeps the VCO frequency. Since IC2 is an inverting stage, an increasing voltage at J1 yields an increasing

which programs the chip to accept an external clock.

The rest of the circuit is the same as that described in the last installment, with the noise taken off of timing capacitor C1. We have to take out the noise this way since the chip's normal output, pin 13, is already committed to the VCO.

**Calibration.** To adjust trimmer R6, turn down R1 and R3, and advance R6 until the noise just begins to be audible. This sets the lowest noise frequency.

Once the circuit is calibrated, start experimenting. You could apply an ADSR to J1, or an envelope follower, LFO, sequencer, etc. - you get the picture; we're talking about a staggering amount of sounds, and they're all extremely useful. If you thought white noise had to be a static, one-dimensional effect, this circuit will definitely turn your

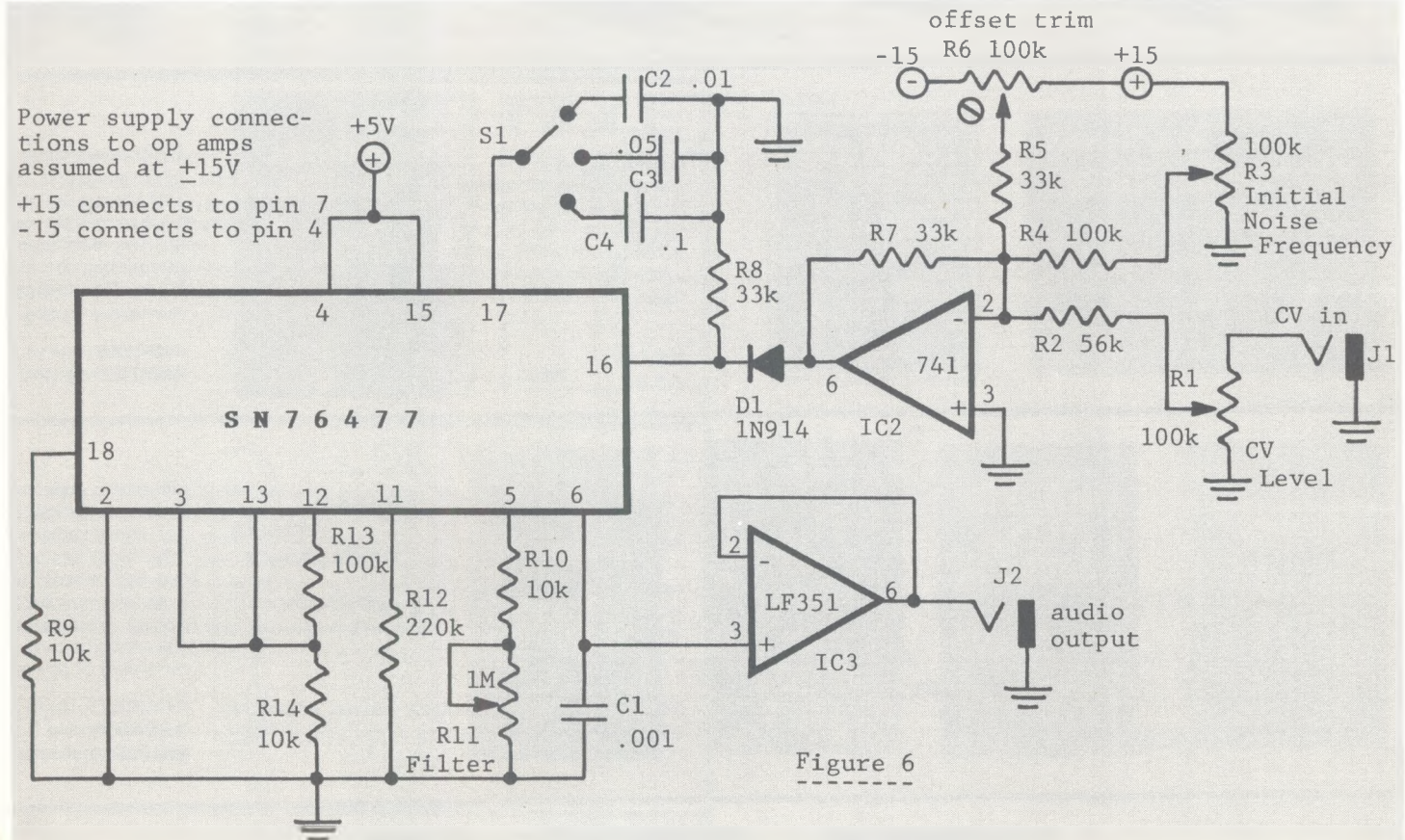

Figure 6

cet, POLYPHONY, Nov/Dec 19779, pp 12-13, corrections in the Jan/Feb 1980 issue, p 5).

**Expanded noise sweep.** Sweep- ing noise effects really appeal to me, and ever since discovering how to do them, I have been constantly, at work developing new ways to employ this technique. One of the limitations of the circuit in figure 5 is that the internal noise clock is slightly limited in

frequency. R3 offsets the VCO if desired, or can be used as a manual sweep control. Trimmer R6 sets the zero point of the VCO so that 0V applied to J1 gives the minimum VCO frequency. Diode D1 prevents any inadvertent negative voltages from creeping into the VCO. The VCO's square wave output is taken off of pin 13 and sent to the external noise clock input at pin 3. Pin 4 is tied to the +5V line,

head around.

Next month, we'll tie together what we've covered so far, plus more, with a complete project, the "Super Controller Module". I think you're going to like this one!

**Acknowledgement.** My thanks go to Craig Anderton for turning me on to the use of a transistor to control the internal noise clock. © 1981 Thomas Henry



# POLYMART

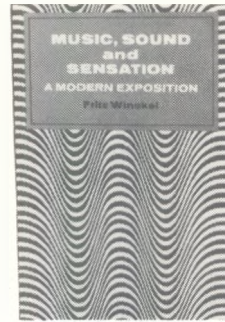
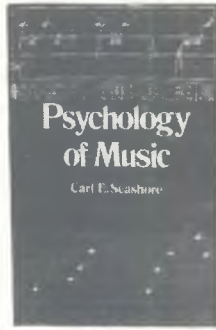
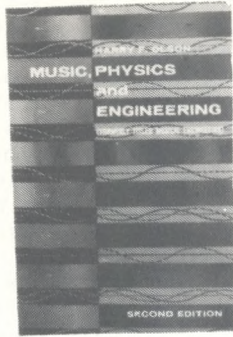
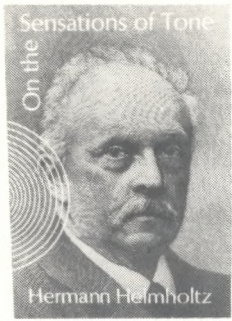

The physical and psych Helmholtz's **Sensatio** physiological acoustics Test, provides an in- instruments. **Music**, synthesizer, is a thoo instruments (plus a chi like the Helmholtz wo

#SENS On The Sense  
#MPE Music, Physics

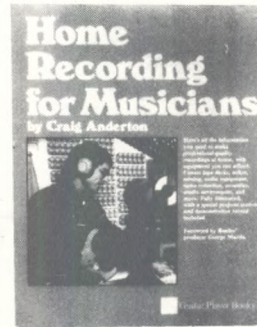
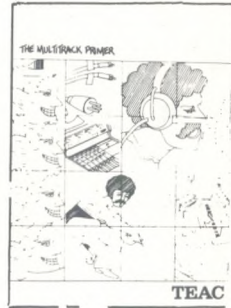
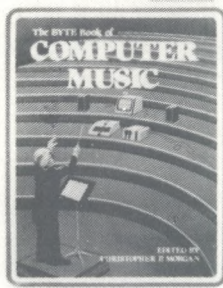
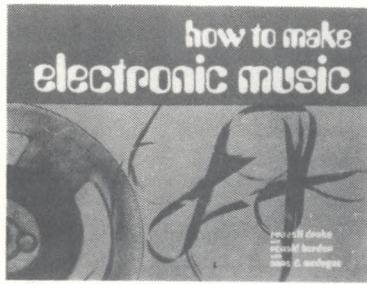
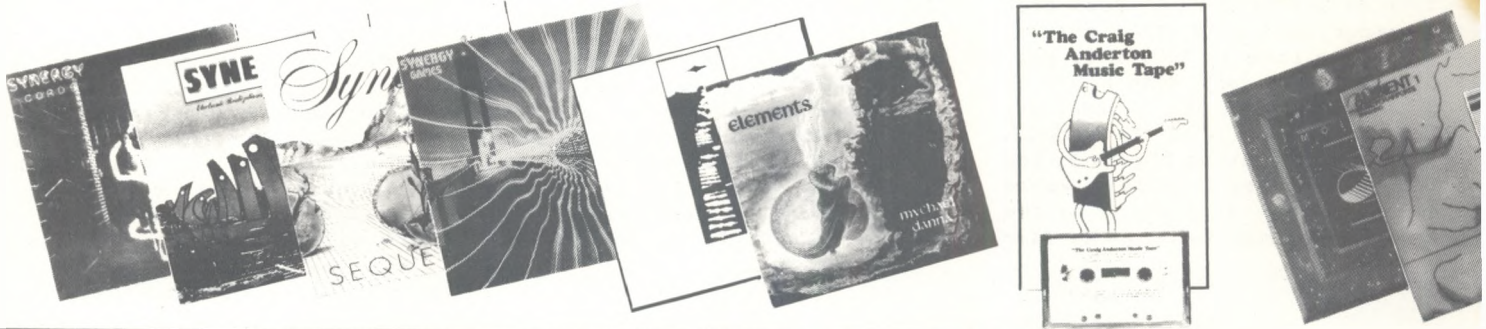

Synthesists must be w books are a great way t and Modugno is a stanc tape technique, compos building, outfitting, and computer control of el **Home Recording For** maximum results, inclu

#HMEM How to Make  
#BYTE Byte Book of C

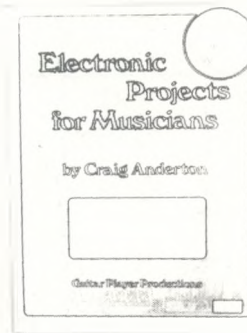
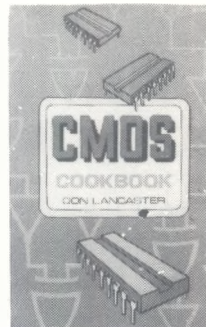
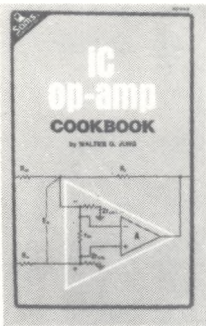

Electronic cookbooks a theory, definitions, and i can easily replace stac reference. Walt Jung's required reading for sy applications. Lancaster octave generators, too electronic construction recording of the effect:

#OACB Op-Amp Cook  
#AFCB Active Filter C  
#AUOA Audio Op-Am

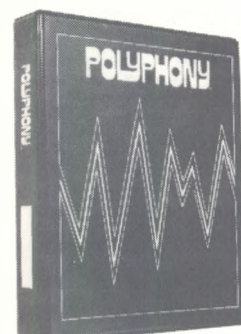
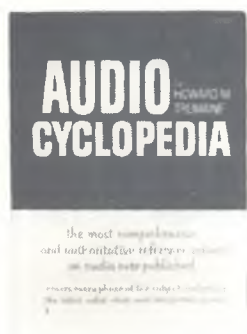
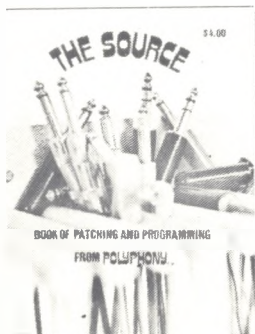

Often used reference n **The Source** is over 12 type. **Audio Cycloped** to answer any question publication without pur **Synthesizers** devote: Paia, Oberheim, EML, experimenter.

#SOURCE The S  
#CYCLO Audio  
#EMS Music  
#BIND Binde





# BACK ISSUES

The wide variety of practical applications and construction projects in past issues make a binder full of Polyphonys a frequently used reference to keep near your synthesizer, home studio, or workbench. Most issues are still available for \$2.50 plus \$.50 shipping/handling. Check the issues desired on this coupon and add the total to your PolyMart order (other side), or order by volume and issue number (0304, 0402, etc.) on the PolyMart form.

#0101: 1975: SOLD OUT #0202: 2/76: SOLD OUT  
 #0201: 1/76: SOLD OUT #0203: 3/76: SOLD OUT

#0204: 4/76: music notation - timing, external inputs for Gnome, Programmable Drums, Equally Tempered D/A, low cost AR project, digitally encoding keyboards, patches, Volume 1 & 2 index.

#0301: 7/77: frequency divider project, random tone generator project, normalizing synthesizer controls, eliminating patch cords, computer control of analog modules, Chord Egg modification, adding pitch bending, patches.

#0302: 11/77: The Sensuous Envelope Follower, digital gates, LED wall art, build a bionic sax, data to music peripheral project, Apple II as a music controller, using the NE566 as a VCO, patches.

#0303: 2/78: computer controlled Gnome, using joysticks, build a bionic trumpet, ultra-VCO modifications, voltage control the Mu-Tron Bi-Phase, oral joystick, patches.

#0304: April/May 78: Minimoog modifications, non-keyboard module use, phasing and flanging (theory and circuits), memory expansion for programmable drums, digitally addressed transposer project, polyphonic software (with software transient generators), patches, Volume 3 index.

#0401: July/August 78: analog delay lines (theory and projects), composing for electronic music, note to frequency (and visa versa) conversions, build a trigger delay, software for computer composition, low cost VCO circuit, patches.

#0402: Sept/Oct 78: electronic music notation, notes on the recording of "Cords" by Larry Fast, sequencer software - part one, rhythmic control of analog sequencers, touch switch projects, modular vocoder techniques, PET as a music controller, patches.

#0403: November/December 78: SOLD OUT

#0404: January/March 79: add-ons for vocal F and V converter, shorthand patch notation, more on note to frequency conversion, graphic monitor project, George Russell, super VCA circuit, echo software, Vol. 4 index.

#0501: May/June 79: SOLD OUT

#0502: July/August 79: hex VCA/mixer project, electronic music schools and studios, modify the Oberheim Expander Module, profile of Ernest Garthwaite, budget microphones, digitizer projects and software, bar graph ICs.

#0503: September/October 79: SOLD OUT

#0504: November/December 79: SOLD OUT

#0505: January/February 80: Joseph Byrd, Mort Garson, Larry Fast on 'Games', composing for 'live plus tape', using the CA3280, recording vocals, ADSR circuits.

#0506: March/April 80: Computers in Music: real time audio processing hardware, Powell sequencer system, Max Mathews, advanced STG software, PortaStudio, phase modulation, Volume 5 index.

#0601: May/June 80: SOLD OUT

#0602: July/August 80: Peter Gabriel, digital VCO project, dream modules, optimum level settings, dynamic phrasing, patches.

#0603: Sept/Oct combined with Nov/Dec 80: alternate controllers, add voices to Casio M-10, voltage controlled quadrature oscillator project, cordless patch bay, recording rules, patches.

#0604: January/February 81: Special Construction Edition; Build: Audio Circuit Breaker, Pulse Width Multiplier, Magnetic Harp, 50 Watt/Channel Stereo Power Amp, Quad Sequential Switch, DOD Mods, patches.

#0605: March/April 81: Portable Music Issue, reviews of Remco's FX, E-H mini-synthesizer, Casio VL-Tone, plus mods for the M-10, GR-500, mini-amp, and the Korg X-911, Introducing: Practical Circuitry and On Location, new columns

#0606 May/June 81: Synthesizer: Hardware Mods & Software. Modular Synthesizer Effects, Environmental music, Keyboard assignment for the 8700, new columns; Details, Practical Circuitry and On Location. Volume 6 index.

## MORE - FROM - POLYMART

USE ORDER BLANK ON PRECEDING PAGE

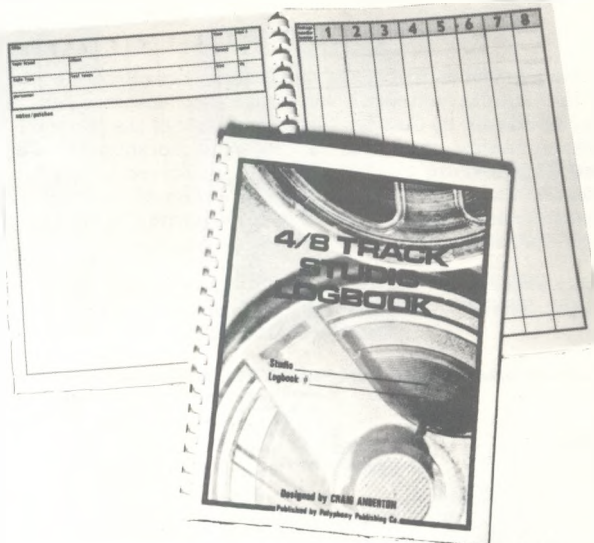

Without a logbook remix and overdubs often mean going back to re-familiarize yourself with the piece. Having all the important information on your tape library in one place as opposed to take sheets scattered among a lot of different reels is convenient but more importantly, a well-kept logbook becomes part of your records for tax, accounting and planning purposes.

This 4/8 Track Studio Logbook represents an improvement over standard track sheets in that you can not only indicate technical information such as timing and type of tape used; there is also a generous amount of space for recording patches and making notes, as well as an expanded track sheet page that provides space for listing sequential changes in various tape tracks and relating these to settings of the index counter.

Order # SLB.....\$4.95

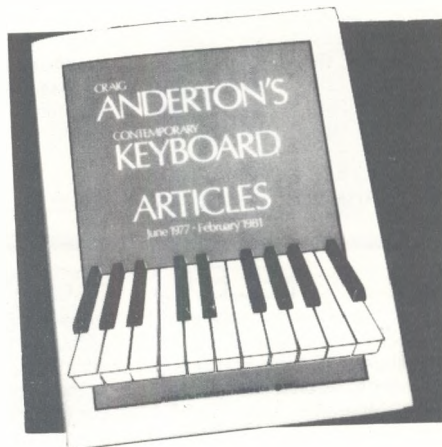

For those of you who have been asking for Craig Anderton's Contemporary Keyboard reprints (June 1977 - February 1981) here it is. Article topics include tips, technique, theory, maintenance and projects, such as, Design and Build; Keyboard Mixer, Keyboard Pre Amp, Multiple Identity Filter, Combo Organ, Tremolo, LED Control Voltage Meter, Expansion Oscillator, Noise Generator, and more.

Order # AA .....\$6.95

## DEVICE AVAILABLE...

Since DEVICE and POLYPHONY merged, one of our most requested items has been DEVICE back-issues. And no wonder; during the year that this newsletter for guitarist/musician was published it featured an extraordinary quantity of material of interest to anyone involved with music at any level. These twelve issues provide almost 200 pages of solid technical information ranging from design and construction of Craig Anderton's AMS Modification System to modifying and customizing some of the most popular audio effects and processing equipment available.

Don't miss out, there are a limited number of back-issue sets available and when they are gone they will not be re-printed, so order yours today. Sorry, re-prints of individual issues are not available.

Device Back-Issue Set.....\$18.00 ppd.



# Applied Synthesis: MARKETING YOUR RECORDS

by Bill Rhodes

So you're going to bypass the major companies to produce and release your own record? More power to you! But, there are still some complications involved with doing it yourself, so perhaps you can benefit from my experience with an independent record label (Jazzical Records).

Without going into recording technique, record production, jacket design, etc. (which is your business) let's approach marketing head-on. The most important aspect of selling records is **advertising and promotion**. This can be accomplished in many ways:

- Radio airplay is the most widespread device to get any product to the potential buyer's ears. Bug your local DJ with information, EPs, LPs, or whatever your band has recorded. Make a nuisance of yourself to get the airplay you deserve. Don't forget DJs are inundated with promo records by the hundreds every week; but if the DJ knows you are local talent, and you are persistent in your communications with the radio station, the chances are excellent of getting airplay.

- Search out record or music stores that will accept your records on consignment, namely, you give them "X" amount of records and they pay you when the albums are sold. But remember, your success is proportional to advertising and publicity. Make an extroverted poster dealing with your product and submit it to each store with which you wish to advertise.

- Contact local radio stations about advertising your records on the air. Most stations offer surprisingly low rates at night (not prime time) for 30 and 60 second spots. Extract material from your record that is easily remembered after only a cursory listening for the ad, and get a pro to do the voice-over to give the spot a professional veneer.

- Mail-order advertising through a magazine can be extremely profitable. **Polyphony** is great for marketing independent electronic music because the readership is geared to that progressive niche. Use your head when you

design the ad. Keep the price of your records lower than the biggies but don't sacrifice professionalism in your marketing. Color is nice (and expensive!), but remember that a good black-and-white ad looks as good as color if it is well-designed.

- Publish and distribute free brochures describing what the average buyer can expect from your product. Distribute these brochures at record shops and retail music stores if the owners are agreeable; also try to get a mailing list from whatever sources you can and mail the brochures to people interested in your record. For example, if your music is keyboard oriented (which is the case with Jazzical records), get a list of keyboard players in your area (often available from musician union directories) and mail brochures to them.

- Include an address right on the record jacket that people can write to if they want to comment on your album. With the comments coming in you will have the beginnings of a mailing list to use for future releases.

- If your output includes more than one album, include a discography of previous and "soon-to-be-released" records on the album jacket back. This is free advertising and the DJs can use this as reference in selecting other tunes for airplay.

- Have patience, make a trillion phone calls, try to get free advertising any way possible (giveaways to radio stations are extremely useful in promotion), and spread the word to anyone in the media.

So much for marketing; now for one last word of a more technical nature, concerning pressing plants. One of the most competent, prompt, and interested plants I've found is QCA Custom Pressing (2832 Spring Grove Avenue, Cincinnati, OH 45225). They are primarily geared to independent labels with small resources, and their prices are extremely competitive. Contact Keith Myers in your correspondence and you will get excellent results. **C**

# SERGE

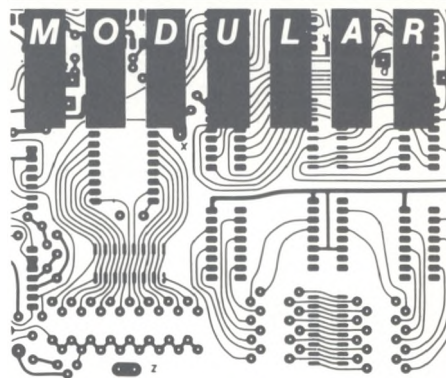

FOR A COMPLETE SET OF DATA SHEETS ON THE COMPREHENSIVE LINE OF SERGE SYNTHESIZER MODULES SEND \$3 TO:

**Serge Modular Music Systems**  
572 Haight Street  
San Francisco, CA 94117  
(415) 621-6898

**Programmable.**

RMS has something new. We've added new features, modules and improvements to make the Aries a great programmable, modular synthesizer. And it's affordable.

**RMS** Rivera Music Services  
48 Brighton Avenue #11, Boston, Mass. 02134

# FENDER AMP MOD

by Lee Powell



Fender®

Many Fender amplifier owners have wanted to reproduce the full-blast sound of the amp, but at lower volume levels. Adding a master volume control accomplishes this purpose, as it can lower the final sound level, allowing the original volume control to be cranked up to 10. This modification has become so popular that it is built-in on the newer Fender amps.

Periodically, technically inclined guitarists ask me for schematics to Fender's updated circuit so that they can "upgrade" their amps. But when you look at the revised circuit, the design is so confusing that, at first glance, it appears they may know something that we don't. Surely, I reasoned, there must be some urgently compelling reason for using such a monstrous part as a center-tapped potentiometer into which has been grafted a pushpull DPST switch (available only from Fender by special order through an authorized retail store). And the macabre use of feedback into the reverb tank...obviously that must impart some kind of startlingly unique texture to the sound. Plus there is the mysterious connection of the master volume pot into the power amp feedback loop from the output transformer...hmm...

In spite of the unknown advantages of Fender's elaborate design, independent technicians have for years been installing

master volume controls, using a shamelessly simple trick. Figure 1 shows a simplified drawing of the output and driver stages of a typical 50 Watt Fender amp (100 Watt Fenders are basically the same, but include two extra power tubes in parallel with V7 and V8. Smaller amps - except for the Champ - have similar circuits as well). V6A and V6B are connected as a differential amplifier, supplying a pair of balanced signals to the inputs of power tubes V7 and V8. The outputs of the power tubes are developed in the primary coil of the output transformer, whose secondary coil connects to the speakers. To install a master volume control, all that is necessary is to connect a 500k audio pot across the inputs of V7 and V8!

As shown in figure 1, the 500k pot connects between the two 1.5k resistors wired to the inputs of V7 and V8. These two resistors are mounted between pins 5 and 1 of the tube sockets for V7 and V8. Wires from pin 1 of each of these tube sockets can be traced to two solder grommets on the circuit board, directly behind the BASS control of the VIBRATO channel. These grommets provide us with convenient terminals for connecting the two wires from the 500k master volume pot.

The master volume pot itself is usually mounted in the hole previously occupied by the tremolo

Fender is a registered trademark of CBS Musical Instruments



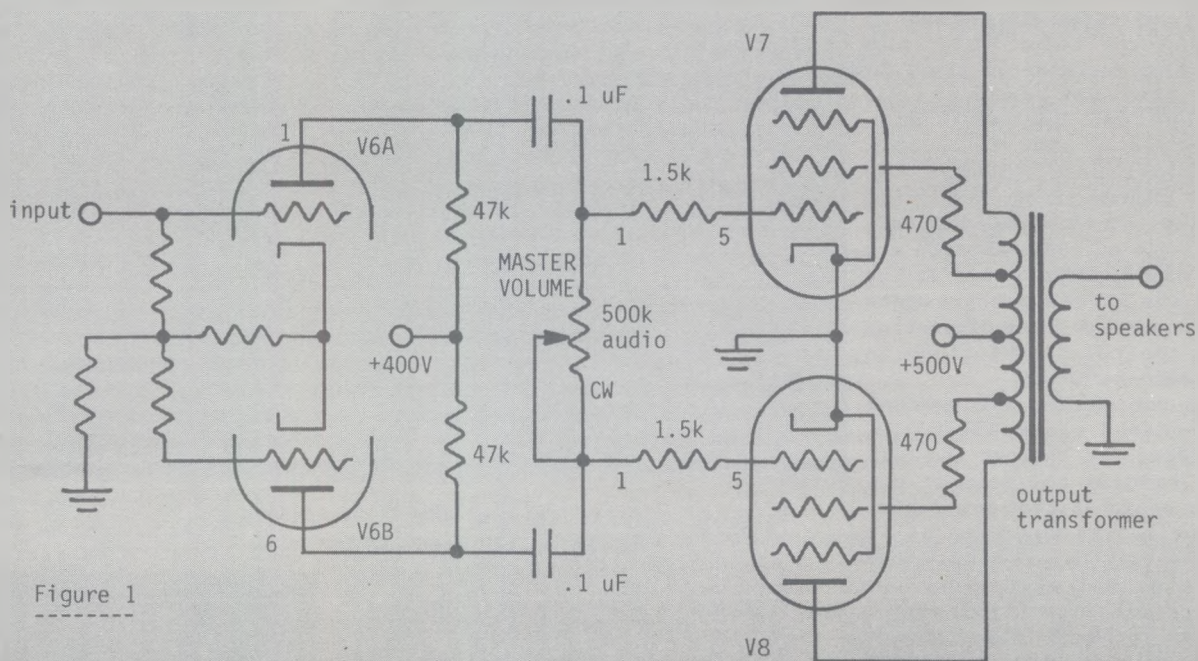

Figure 1

INTENSITY pot, which is then exiled to some lonely spot on the rear panel, and henceforth ignored. Some guitarists, after years of relentlessly boycotting the unique tremolo capabilities of their amps, take this opportunity to eliminate it entirely by soldering the middle terminal wire to some nearby ground connection, and ditching the pot. Others, caring less for cosmetic appearance than total access to all controls, wind up drilling a hole through the front panel nameplate, mounting the master volume pot there. True to its reputation for standing up under abuse, the Fender amp thus mutilated does not seem to suffer in resale value.

Alternatively, for those guitarists who are not sure why they wanted the master volume control in the first place, you can mount it in the same inconvenient spot on the rear panel that is usually reserved for the neglected tremolo INTENSITY pot. This will make it quite difficult to adjust during performance. Whatever you do, however, twist the master volume pot wires together in the same fashion as the tube heater wires. Omitting this crucial detail would violate a long-standing tradition - and leaves the unmistakable mark of a non-professional job.

As popular and effective as this modification has proved to be over the years, one drawback is that the master volume control

distorts both the VIBRATO and NORMAL input channels at the same time. This means that the NORMAL channel can't be used, to amplify another instrument along with guitar, since serious intermodulation distortion would result. To overcome this difficulty, I have developed an alternate master volume scheme, which produces distortion in the final amplifier stage of the VIBRATO channel alone. Since the signal from the NORMAL channel does not pass through this tube, it remains undistorted and operates normally. Thus the mas-

ter volume control affects the VIBRATO channel only.

Figure 2 shows the final gain stage of the VIBRATO channel in a typical Fender amp (Fender amps that don't have built-in reverb do not have this stage, and are not good candidates for this type of master volume control). At the input of tube V4B, the ordinary sound of the guitar from tube V2B is mixed with the sound of the reverb from tube V4A. The output of V4B is then mixed with the signal from the NORMAL channel (V1B), and sent to the power amp.

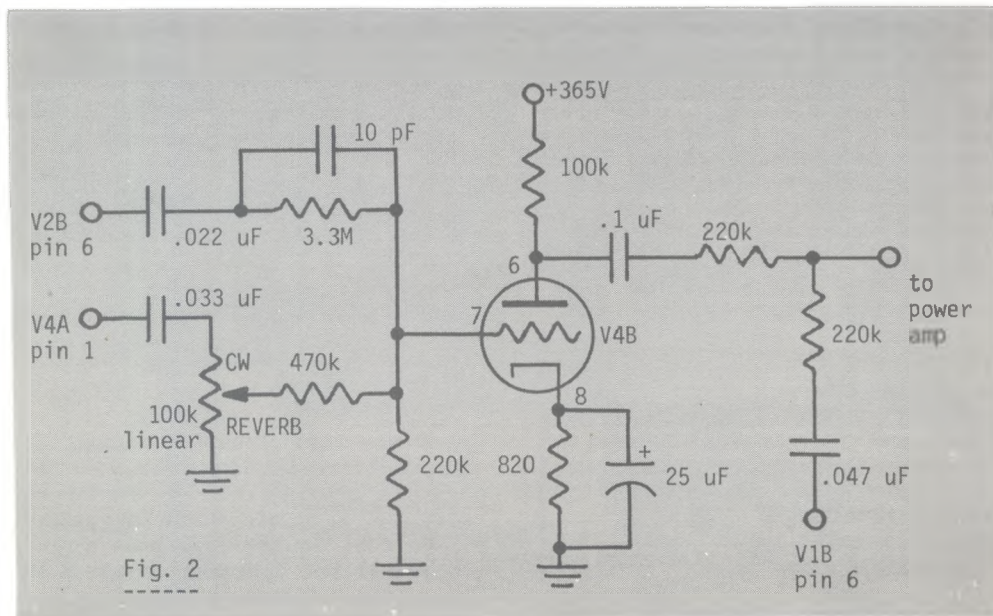

Fig. 2







# Taking control of your **MXR** Phase 100

\* trademark of MXR Innovations, Inc.

by **Matt Richards**

I've owned an MXR Phase 100 for about 5 years now, and consider it one of the best phase shifters around. However, the sound of a phaser whooshing back and forth without regard for the rhythm of a piece of music can get a bit tiresome. The answer is foot pedal control, and this mod shows you how to do it.

**How it works.** The amount of phase shift is controlled by the amount of current flowing through the LEDs in three dual opto-isolators. A Darlington transistor pair controls this amount of current; in this mod, we break the connection between the LEDs and the controlling transistors, substituting a pot for the transistors to give us manual control over the phase shift. Mounting this pot in a footpedal gives us footpedal control.

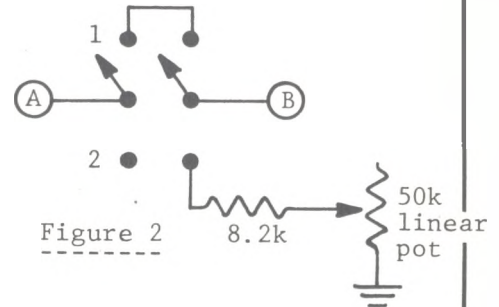

Figure 2

cut trace at "X"

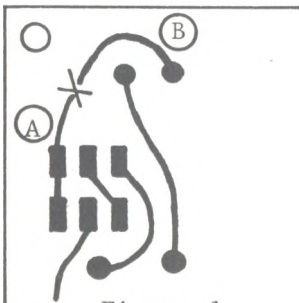

Figure 1

**The modification.** Look at the foil side of the circuit board, with the wire connections on the bottom; the upper left hand corner should be marked P100. Figure 1 shows a detail of this section of the board. Cut the trace between points A and B as shown to disconnect the opto-isolators from the driver transistors, then connect up points A and B to the circuit in figure 2. Work fast when soldering, especially point B - you wouldn't want

to burn out that opto-isolator!

With S1 in position 1, you will have the standard phase shifter sweep. In position 2, the potentiometer will control the phase shift sweep. If you mount this pot in a footpedal, don't worry about noise pickup on the line to the pedal, since this part of the circuit does not carry any audio signal. Good luck - I hope you enjoy being able to control your Phase 100 as much as I do. **C**

## PLUG IN TO POLYPHONY

for electrifying communication

from other experimenting  
musicians.

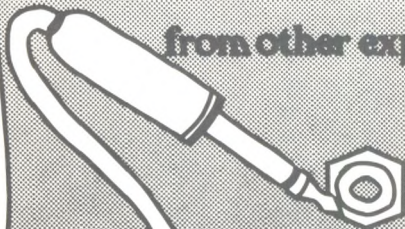

### SUBSCRIPTION RATES:

	U.S.	FOREIGN
one year	\$12.00	\$14.00
two years	\$22.00	\$26.00

Name \_\_\_\_\_

Address \_\_\_\_\_

City \_\_\_\_\_ State \_\_\_\_\_

Zip \_\_\_\_\_

## Quality Effects

These new stomp boxes from PAIA are designed to give electronic guitarists the highest quality effect at the lowest possible price. Cases are formed of heavy steel and covered with the most scuff-resistant baked-on finish available. Both feature heavy duty switches for long life and electronic effect switching for pop-free punch-in and punch-out. Both are high input impedance, low output impedance, non-inverting, low noise devices designed to meet all proposed FX standards. Each provides hour after hour of operation from a single 9 volt battery and provide automatic power switching - you'll never have to worry about forgetting to turn them off.

No. 5720 MOJO Filter Kit . . . \$34.95 Assembled \$49.95 (3 lbs.)

No. 5710 HOT LYX Sustain Kit . . . \$34.95 Assembled \$49.95 (3 lbs.)



PART OF THE NEW GENERATION FROM  
**PAIA Electronics, Inc.**

1020 W. Wilshire, Oklahoma City, OK 73116 (405) 843-9626

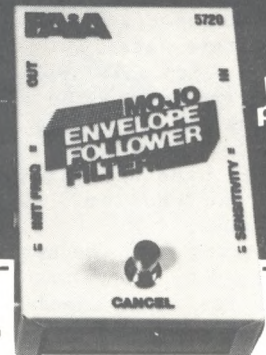

low prices

- Send No. 5710 Hot Lyx Sustain
- Send No. 5720 Mojo Filter
- Kit - \$34.95  Assembled - \$49.95 each (+\$3 postage) enclosed.

Send FREE CATALOG

Name: \_\_\_\_\_

Address: \_\_\_\_\_

City: \_\_\_\_\_ State: \_\_\_\_\_ Zip: \_\_\_\_\_

VISA  MC  Card no.: \_\_\_\_\_

PAIA Electronics, Inc., dept 11-Y, 1020 W. Wilshire Blvd., Oklahoma City, OK 73116

FREE SHIPPING WHEN ORDERED WITH THIS COUPON

# DETAILS: The Story of Gozinda & Gozouta

**The not-so-balanced input.** Balanced inputs are a thing of beauty. Magic, really. They take two signal lines and amplify only the difference between them while rejecting anything that is common. Neat. The common stuff is all the garbage induced in the lines as they dutifully connect two pieces of equipment. Hum, noise, your un-favorite radio station, local police and CB radio signals, radar, fluorescent lights, life itself - all competing to violate your pure signal as it tries heroically to traverse from one piece of gear to another.

Many solutions exist to accommodate balanced inputs. Transformers are the most common, and the most expensive, and the most troublesome. So much for transformers.

**Transformerless balanced inputs.** Heading the list of transformerless balanced inputs is the single op amp difference amplifier of figure 1. From

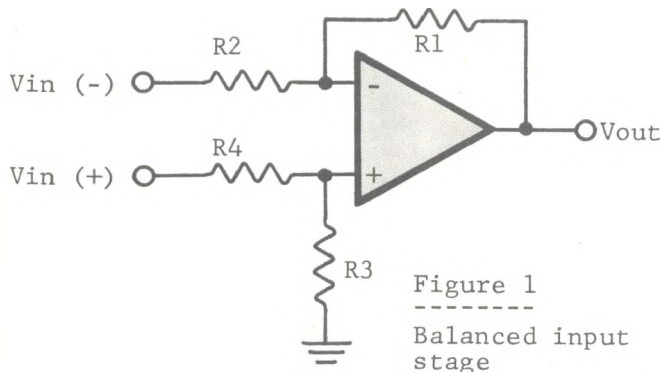

Figure 1  
-----  
Balanced input stage

here the solutions expand (as does the cost) to two and three op amp instrumentation amplifiers. The main advantage of the more complex circuits is their equal input impedance characteristics. A characteristic not exhibited by the single op amp difference circuit, with one exception. Patience, I'm getting to it!

Back to figure 1. If  $R1 = R3$  and  $R2 = R4$ , then the circuit amplifies the difference between the inputs by the factor  $R1/R2$ , i.e.,

$$V_{out} = R1/R2 (V_{in+} - V_{in-})$$

Any signal common to both inputs will not be amplified at all, providing all resistors are perfectly matched and you are using a decent op amp. More on this later.

For unity gain applications, all four resistors will be equal, and the circuit performs the important task of converting line level balanced inputs to single ended outputs, and is probably the most commonly used circuit for signal processors. So what's the problem? Unequal input impedances, that's what.

Looking into the negative port, the input impedance seen by  $V_{in} (-)$  is  $R2$ , while  $V_{in} (+)$  "sees"  $R3 + R4$  as its input impedance. Typical numbers would be for all resistors to equal 20k Ohms, therefore the negative input impedance is 20k Ohms to ground, while the positive input impedance is 40k Ohms to ground. Why is this a problem? It isn't, for some. For others, it creates a system full of humming birds.

The difference is the output impedance of the driving circuits. If it is zero (wistful thinking) then an unbalanced input impedance is not a problem, since the impedance of the connected lines is zero and nothing will be induced. As the output impedance is increased, then so is the impedance of the connected lines. If it is equal, then what is induced will also be equal and the common mode rejection of the circuit will not allow the garbage to pass; however, if the output impedances are fairly large (several hundred Ohms is plenty) then the mismatch in input impedances will now cause the connected lines to have unequal impedances and the induced garbage will not be common, but different. This is then converted as signal and everything goes to Hell. Hence, the popularity of instrumentation amplifiers with their equal input impedances. But, all is not lost - remember the one exception?

It turns out, in general, that if  $R1 = R2$  (not  $R3$  as previously stated) and  $R3 = R4$  then you also get a unity gain difference amplifier, and, specifically, if  $R2 = R3 + R4$  then you get a truly balanced input amplifier with unity gain (it doesn't work for gains greater than unity - sorry). Letting  $R1 = R2 = 20k$  Ohms and  $R3 = R4 = 10k$  Ohms satisfies our requirements and yields equal input impedances of 20k Ohms to ground for each leg. The answer to the not-so-balanced input stage is so obvious that most designers have missed it (or ignored the problem) for years. Now, you have the heart of a general purpose balanced input stage that, with a few embellishments, will serve for any projects you may have requiring balanced operation.

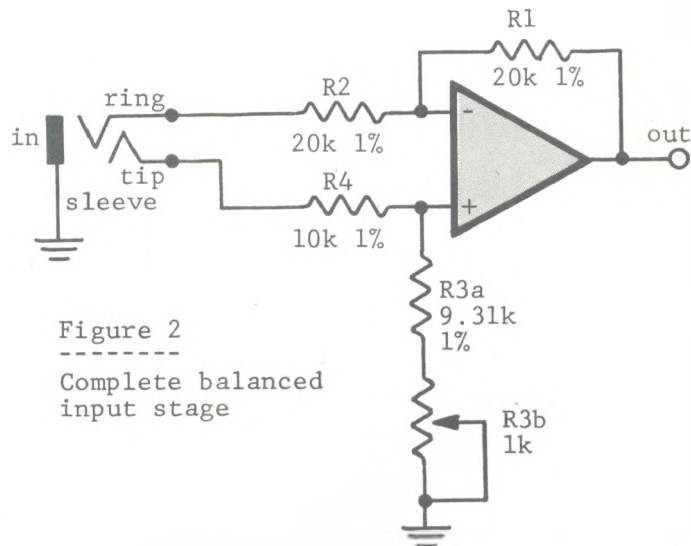

Figure 2  
-----  
Complete balanced input stage

Figure 2 shows a complete balanced stage with a stereo 1/4" phone jack input. There is a bit of cleverness going on here that comes for free. Using a stereo phone plug into the stereo jack gives you the balanced line input - obvious. Not so obvious is that by using a mono phone plug, the circuit automatically switches to unbalanced single line operation. Nice, huh? What happens is that the ring of the jack gets shorted to ground by the mono plug and turns the difference amp into a non-inverting stage with a gain of two, but there is a 6 dB pad hung on its positive input, so the net result is



a gain of one, unbalanced input. The stage becomes even more universal now, being either balanced on unbalanced, depending only on whether the input plug is stereo or mono.

Trimpot R3b is added as a "tolerance soak", since this one adjustment will soak up all of the resistor mismatches. A common mode signal is applied to the inputs (e.g., tie both inputs together and drive with a signal generator set for 2 Volts output and 1 KHz) and R3b is then adjusted for minimum output. One percent resistors are required if any kind of decent common mode rejection is to be gained, since any mismatch will cause a common mode input signal at the resistors to appear as a difference signal at the actual op amp input terminals.

So much for down and dirty balanced inputs; now how about an equally dirty "balanced" output that will blow the socks off more elaborate versions?

**The not-so-balanced output.** Balanced outputs have evolved in a similar fashion to balanced inputs; starting out with everything using transform-

other, more complicated schemes involving reverse feedback circuitry to guarantee that the differential output signal is virtually immune to loading effects (using at least four op amps), but each of these circuits share the same problem - they all reference their outputs to the amplifier ground - a definite no-no for hum-free systems.

The best solution, as is so often true, is the simplest. It is no more complex than figure 4. By

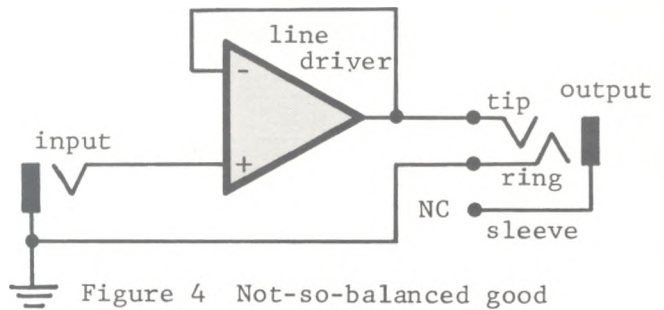

Figure 4 Not-so-balanced good output stage

taking a regular single-ended (unbalanced) line driver and floating its output and ground, you create a compatible system for driving differential (balanced) inputs that is trouble-free. Figure 5 shows the interface between the two systems. Note that while the chassis of each unit may be at the same potential, their signal grounds are allowed to be at different potentials. This is very important in keeping hum common mode, and not differential. Any difference of potential existing between the two grounds is seen as a common mode signal and is rejected.

Like the balanced input stage of figure 2, the "balanced" output stage of figure 4 automatically switches to a conventional unbalanced output stage if a mono phone jack is used for interconnection. The ring of the jack gets shorted to the sleeve, thus grounding the sleeve as you would in a normal balanced system.

So, there you have it: A universal input/output scheme that is balanced or unbalanced, depending upon the required application...just like apple pie and cheese. ©

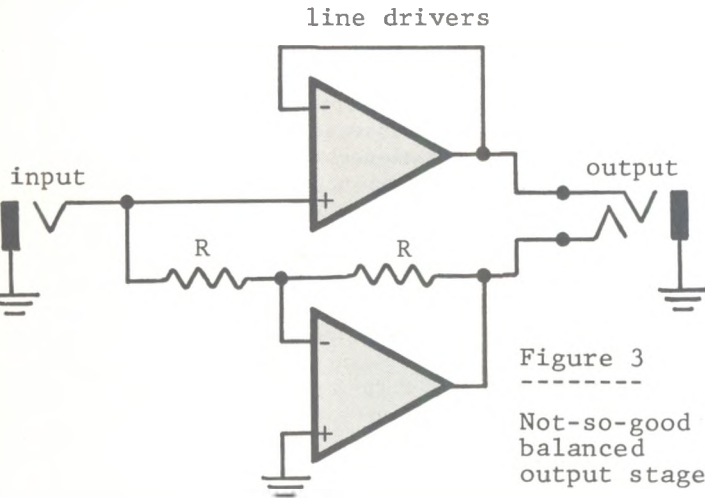

Figure 3 Not-so-good balanced output stage

ers and gradually moving toward transformerless solutions. The most commonly seen solid-state circuit involves two op amps as shown in figure 3 (or some variation of this configuration). There are

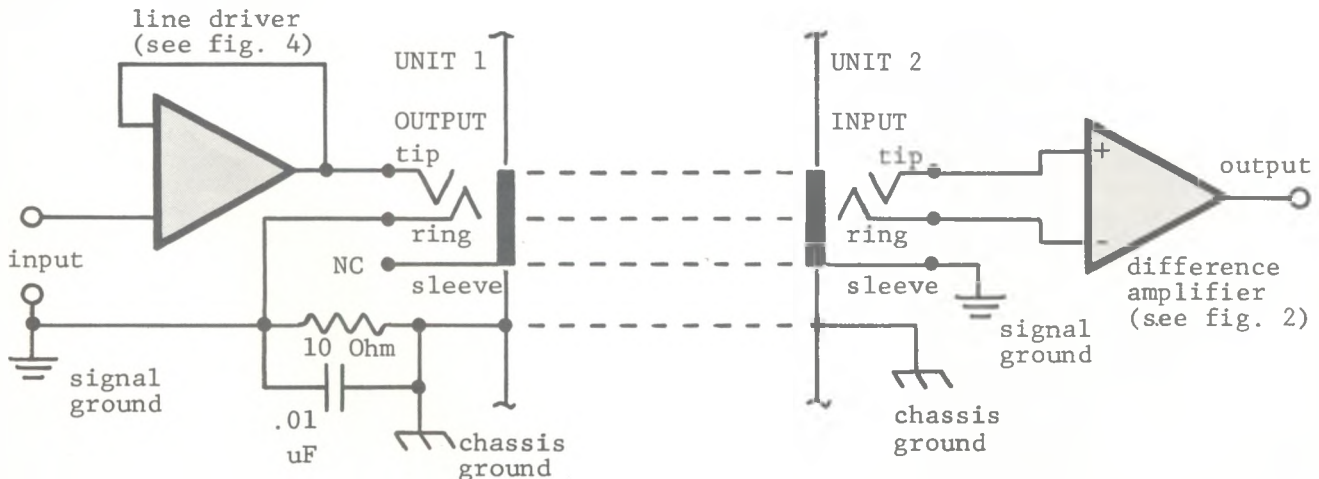

Figure 5 Interconnection between units

# GR-500

## Comments and Mods

by Robert D. Loney

Here are some comments on some of the more popular GR-500 mods, specifically Gary Cowtan's mods described in the March/April issue of Polyphony, as well as comments on some other possible mods.

**Understanding infinite sustain.** One source of confusion to the would-be modifier is the infinite sustain system. This is an electro-mechanical system made up of a hex pickup, buffers, hex switch, filters, string current drivers, the strings themselves, the permanent magnet (in that black box at the base of the neck), and the frets (which are purposely grounded). If you have synth or dual selected on the gtr/dual/synth switch and fret a string, not only are you selecting a pitch, you are closing a switch which forms a close looped circuit. More specifically, the string vibration is converted to an electrical signal at the hex pickup, and then passes to a hex buffer (made up of 1458 op amps). The 1458 outputs go to two places; one path leads to the 24 pin connector and control panel, the other path goes to another set of buffers. From those buffers the signal passes along to a TC5012, which is used as a hex switch in conjunction with the gtr/dual/synth switch. From there the signals pass to a hex filter and then to the string drivers themselves.

At the point where the string vibration would normally begin to decrease in amplitude (because of friction and so on), a few microAmps of current begin to flow in the string itself. Bear in mind that this is an audio current. On its way to ground at the selected fret, this current generates an electromagnetic field corresponding to the audio current. The AC magnetic field interacts with the permanent magnetic field (from the black box), in a positive feedback mode, to create a sort of solenoid action by the string. All of this acts to maintain string vibration, as long as the string is fretted properly.

**Bridge/nut modifications.** With the above information in mind, consider what happens when you replace the bridge and nut with heavy mass, brass types. The audio current travels down the string to the brass bridge, where it is shorted to the other low impedance sources (which are either quiescent or vibrating at some other audio frequency) via the conducting brass bridge. This effectively disables the infinite sustain system. A brass nut (zero fret) causes essentially the same problem. Strangely, the symptoms of this problem are not noticed right away; yet sooner or later, the player notices

some funny sounds when the string vibration dies out and glitches to a halt. We suggest, therefore, that the bridge and nut not be replaced.

**Pickup changes.** Changing the low impedance stock pickups to high impedance replacements also interacts with the infinite sustain system. When the audio current first flows in the string, a click noise is generated which is de-emphasized by the lower output pickups. With higher impedance pickups, this effect can cause an audible click noise problem. Theoretically, increasing the pickup signal and decreasing the subsequent buffer gain should maintain the same signal-to-noise ratio, but under some conditions the problem persists. Therefore, anybody who wants to change their pickups should be prepared for some experimentation and comparisons.

**Guitar output jack.** This would be a very useful modification, but unfortunately, we have not developed, nor have we seen, a well designed and documented modification along these lines. Anyone who has figured out how to do this is encouraged to send their plans to RolandCorp US (2401 Saybrook Avenue, Los Angeles, CA 90040; tel. 213-685-5141) and to Polyphony so that this information can reach other interested GR-500 owners.

**Speeding up response time.** There is a certain portamento phenomenon which is most noticeable when using some left hand playing techniques with the solo melody or external synth sound sections. This effect is caused by a control voltage gate circuit which averages the CV change unless the string is retriggered by a picking technique. The RC averaging circuit that does this, which is necessary for pitch stability in normal operation, is unnecessarily slow. The resistor in this network can be changed from its present 220k to 180k or possibly 150k. This will not completely eliminate the effect, but it will speed it up significantly. The resistor to be changed is difficult to locate. For those interested in trying this modification, call or write RolandCorp US asking for technical assistance and request the information for the GR-500 F to V circuit mod involving the CV gate RC averaging circuit.

One last tip: As Gary Cowtan says, change your strings often. This not only maintains a bright sound for the guitar section, but also ensures a good string/fret contact which minimizes triggering and sustain problems.

(Robert Loney is a previous Roland service department manager currently contracting his services to that company.) ©



# Advertiser Index

Blacet	29,34
Dickstein Distributing	12
EMSA	34
Godbout	11
PGS	15
Paia Electronics	5,24,25,36
PolyMart	18-19,20
Rivera Music Service	21
Sequential Circuits	2
Serge Modular	21
TEAC (Tascam)	6-7

Proteus I patches thanks to Scott Lee, PAIA Tech Service.

# PATCHES:

Phased Fuzz Guitar I

LFO patched to No. 2 of PW Mod

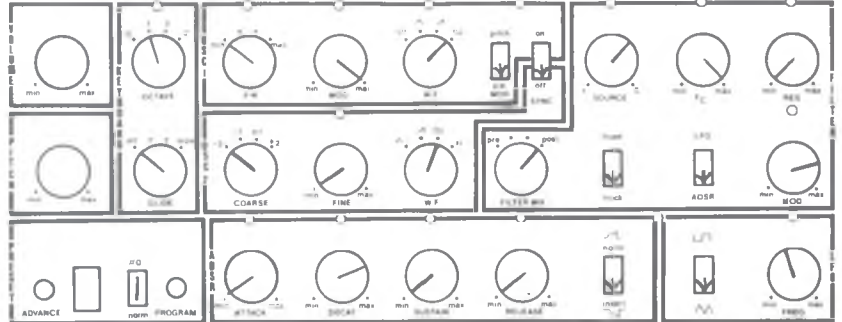

Phased Fuzz Guitar II

ADSR patched to #2 OSC PW Mod

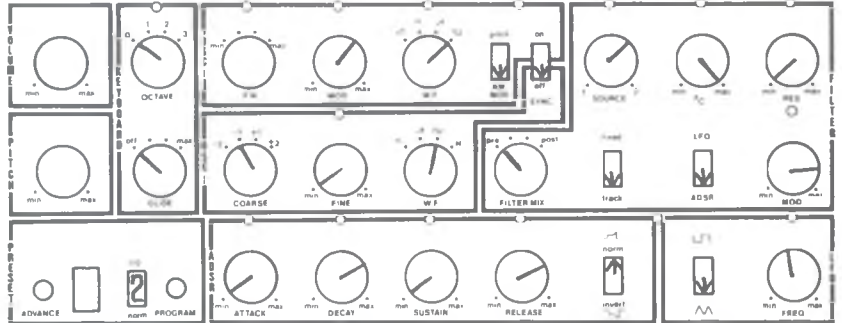

## THE TIME MACHINE.™ A REMARKABLE VOLTAGE CONTROLLED TIME DOMAIN PROCESSOR FOR THE SERIOUS MUSICIAN.

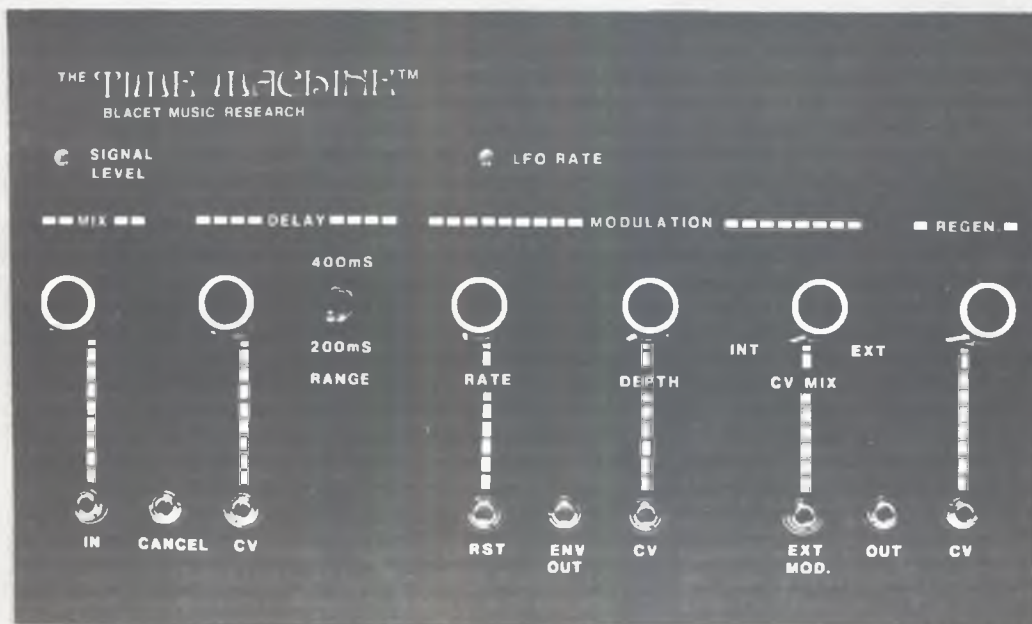

- ☆ Voltage Control of All Major Functions. (Industry standard 0-10V)
- Delay
- Cancel
- LFO Rate
- LFO RST
- Modulation Depth
- Regeneration
- ☆ Envelope Follower
- ☆ Modulation CV Mixer
- ☆ Delay: 200 mS/5KHz  
400 mS/2.5KHz
- ☆ Curtis VCAs, Bi-Fet Op Amps, Brickwall Filters, Componder, ±15 Volt, 6" x 10" x 3".
- ☆ Complete Kit: \$248 (until 12-1-81, \$298 thereafter)

The Time Machine is a lot more than just another analog delay. We've recognized the power of *DYNAMIC* control of delay and designed a processor to take maximum advantage of your controllers. You can use the self-contained envelope follower and LFO, or, external synthesizers, footpedals, computers, etc. Consistent quality throughout. Order today!

Add \$5 S&H US, Canada, Mexico; \$15 elsewhere. CA, add 6%. MC/VISA OK.

BLACET MUSIC RESEARCH

18405 Old Monte Rio Road

Guerneville, CA 95446

# Flora & Fauna of the Patch Cord Jungle

## MODULAR SYNTHESIZER EFFECTS:

### PART II

by Jim Aikin

(In last issue's installment, Jim started off by giving some opinions about the current state of the synthesizer art, and why the synthesizer - which should be one of the most versatile instruments in existence - is often one of the least versatile. To recover that missing versatility, Jim delved into such subjects as the difference between imitative and non-imitative synthesis, percussive synthesis, animation of musical sounds, bell effects, and more. This installment concludes the article by covering additional examples of both imitative and non-imitative synthesis, as well as an extensive discussion on how to get the most out of LFOs.)

**Other Examples of Imitative Synthesis.** Imitative synthesis can involve sounds other than percussion. Crickets, for example, are easy to imitate. Because a cricket starts and stops its chirp suddenly, a square wave LFO is ideal for opening and shutting the filter or VCA. Use two oscillators in the 600 - 800 Hz range, tune them a half-step or so apart, and modulate them with a fast sine wave LFO. The modulation should be somewhat deeper than ordinary vibrato - a whole-step or so. Inverting the LFO on the way to one of the oscillators will help fatten up the sound, as will setting the two LFOs at slightly different speeds.

One other thing will help your crickets a lot: Use two or three of them at once, chirping at different speeds. (Multi-tracking becomes indispensable at this point.) Set the crickets at different volume levels, and give the quieter ones more reverb. Presto - instant summer night. Tricks like this will often give the listener the impression that the patch is very realistic, even if one of your "crickets" by itself isn't an especially good likeness. This is an important principle of imitative synthesis: If a sound is behaving like the acoustic sound it's intended to imitate, the ear will tend to assimilate it and identify it with that sound. If you have your bells strike the hour the way the tower bells at college do, they'll sound more realistic than if they just strike a note or two at random.

Another important point is this: Some of the things you try in the course of setting up an imitative sound patch might not take you in the direction of a realistic sound. But, bear in mind that the sound you discover just might be more useful musically than the realistic sound. Some of the most evocative sounds are the ones at the border of the

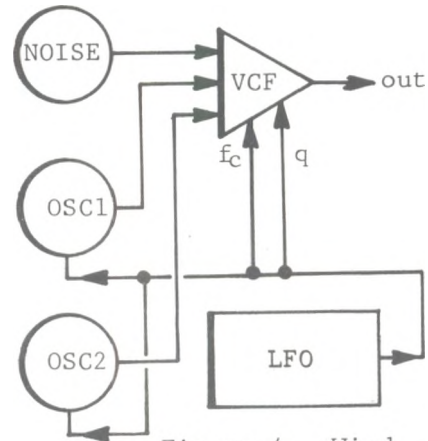

Figure 4: Wind

known. They sound haunting and mysterious, yet elusively familiar. That is, they have an emotional meaning that communicates with the listener on an unconscious, pre-verbal level, even while the conscious mind is unable to exactly identify the nature of the sound.

Before leaving the subject of imitative synthesis, here's some advice for anybody who is tempted to imitate wind sounds: Don't. Wind (and its first cousin, surf) has become one of the instant clichés of electronic music. If, in spite of this caution, you feel you've got a valid artistic use for wind, it's not hard to make some. Just feed some white noise through a filter and modulate the filter with a slow sine wave LFO to simulate the rising and falling of the wind (see figure 4). A filter with voltage-controlled resonance would be especially useful for this patch, because as you raise the cutoff frequency you can increase the resonance with the same sine wave, giving the filter a slight shriek at the top of its rise. In addition to the noise, you might also want to mix in a couple of low-pitched oscillators at low levels for the wind's moan. Modulate these with the same slow sine wave so their pitches will rise slightly as the rest of the wind rises.

The other important characteristic of wind is that it's irregular in period. Rather than use a sine wave LFO at all, you might prefer to use a joystick or some other manual controller to modulate all these functions (filter cutoff, resonance, oscillator pitches) simultaneously. The wind sometimes has sudden surges, sometimes dies away into the distance, and sometimes rises to a sustained howl. If you do use an LFO, to avoid an overly predictable sound you could lay down several tracks of wind with different LFO speeds, or change the LFO speed and modulation depth by hand.

**Basics of Non-Imitative Synthesis.** The key to good-sounding non-imitative effects is really very



simple: Just plug various things into one another and see what happens. When you find something that sounds promising, start thinking about ways to fatten it up. Generally, my non-imitative effects patches seem to use every function on the synthesizer and every patch cord in the house, because I can't help but wonder "now, what would happen if I hooked that up to it?" Of course, simple effects can be very effective too, maybe even more effective in the context of a whole arrangement. The point is just that you'll discover more if you indulge your curiosity and don't have too fixed an attitude about what is, or isn't, possible.

After you've been working with your synthesizer a while, you'll develop a feel for what connections are likely to lead to interesting results. But even then, you may still not know in advance what the patch will sound like when you've hooked it up. The fact that a modular synthesizer set-up retains its power to surprise the user with new sounds is one of its most important and enjoyable features. All the patches dealt with below are things I came up with in this seemingly haphazard intuitive fashion. They sound good to me, and they may give you some ideas of your own, but the only way you're really going to learn about synthesizer effects is to spend enough time with your equipment to develop an understanding of what sounds good to you, and how to go about getting it.

In the preceding discussion we've already touched on several ideas that are just as useful in

non-imitative as in imitative synthesis. Perhaps the single most important idea is this: Oscillators can be modulated by an enormous variety of control voltages. What's more, these voltages can be processed in a variety of ways before they ever get to the oscillators. Oscillators can be modulated by other audio oscillators to produce complex tone colors (this technique is used a great deal in digital synthesis, where it is referred to as FM - frequency modulation). Two or three tone oscillators can be modulated by different voltages; by envelope voltages so that they rise or fall during the course of a note, by noise to turn them into pitched noise, and of course by the ubiquitous LFO - which we will now investigate in some detail.

**LFO Techniques.** Voltage controlled LFOs, which are unfortunately rare on "live performance" synthe-

sizers, are a rich source of modulation. One of the simplest and most interesting things you can do with a modular-type synthesizer is to control an oscillator with an LFO and control the LFO with something else. Here's a simple example: Take the standard envelope that's triggered when you hit a key on the keyboard, and use that to modulate a sine wave LFO (see figure 5). Now you have a vibrato that instead of being static and mechanical-sounding speeds up at the beginning of the note and then slows down as the note dies away, more or less the way a violin player

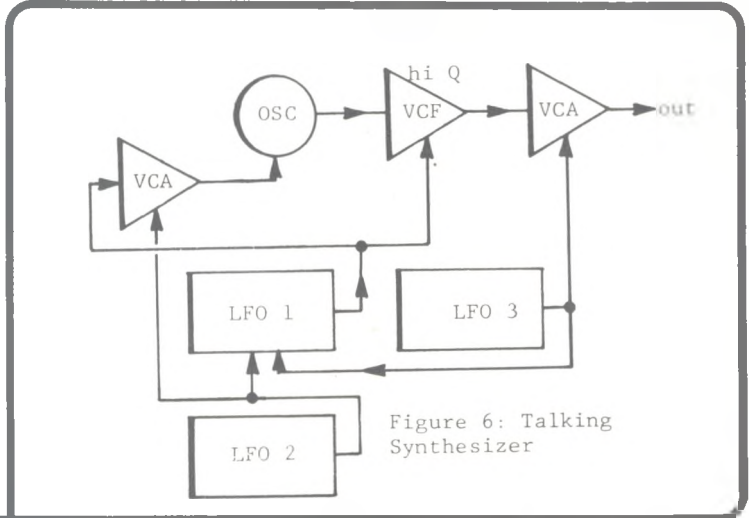

Figure 6: Talking Synthesizer

might impart vibrato to a string. Or, you could invert the envelope voltage so that the vibrato speeds up as the note dies away. If you're fortunate enough to have a velocity-sensitive keyboard and a voltage-controlled envelope generator, it's a simple matter to control the vibrato speed directly from the keyboard as you play.

Some other choices for modulating the LFO include another LFO to change the vibrato speed in a regular way, or a random sample-and-hold to change it in unpredictable ways. And, all this assumes that you're using the LFO's sine or triangle output to modulate a tone oscillator and generate vibrato. You can just as easily use the square wave output to create trills in the same variety of patterns, or the sawtooth output to create - well, sawteeth. Or you can apply the LFO voltage to some other module, such as the VCA, to produce volume swells.

Modulating the LFO with two other LFOs will give it a complex periodicity that hovers at the edge of being comprehensible, with results that can be either hilarious or somewhat disturbing. This will probably sound best when applied to a sustained oscillator tone rather than to a series of discrete notes. In other words, we're no longer talking about playing traditional music on a keyboard but pure electronic sounds. If we go on to route the LFO through a VCA before it gets to the tone oscillator, so that the vibrato will change in amplitude as well as in periodicity, things will start to get quite interesting.

This kind of patch seems to work well when the same LFO is also modulating the filter and there is enough resonance in the filter to give it response peaks corresponding to some of the formant frequencies of the human vocal tract (see figure 6). Don't worry if you don't know what these formant frequencies are - just nudge the filter cutoff frequency and the modulation amount until the filter starts to talk to you. If you've got the patch hooked up right, the filter should start to say, "Wow!"

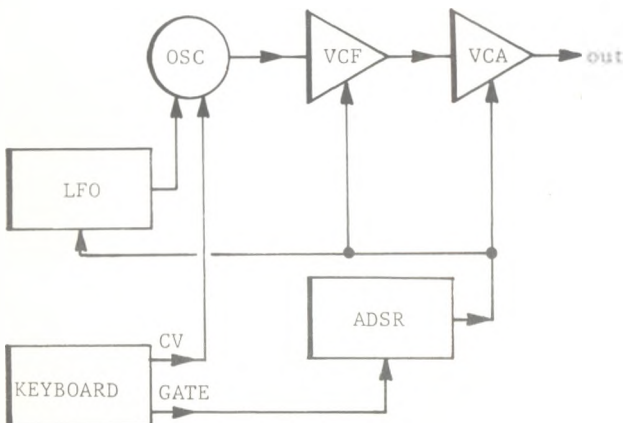

Figure 5: Expressive Vibrato

Ooohhh, Wow!" No kidding. Last week I had a patch like this saying, "I want to be free! I want to be free!" Of course, much of this is in the ear of the listener; you might have heard the same patch saying something different. When it comes to non-imitative synthesis, subjectivity has a wide open field.

Okay, now that we have the LFO behaving in a fairly idiosyncratic way, let's use it for something besides modulation by tapping into the square or sawtooth output and using this as a clock to trigger the sample-and-hold (S/H). The S/H has become another of the cliches of electronic sound, but only in its simplest form (the only form accessible on most inexpensive synthesizers). When the S/H clock is ticking at a regular pace, usually fast, and sampling random noise at its input, what we get is the familiar random stepped voltage output. On a typical small synthesizer this can be applied to control the oscillator pitch or the filter cutoff frequency, and that's about it.

Let's hook the S/H to the oscillator (with any LFO disconnected for now) so that we'll hear the stepped voltage as pitches, but instead of using the regular S/H clock, let's trigger it with our syncopated LFO clock. The same clock should also be used to trigger the envelope that shapes the notes. The notes will have a more or less humorous effect as they bounce from one pitch to another at an unpredictable rate.

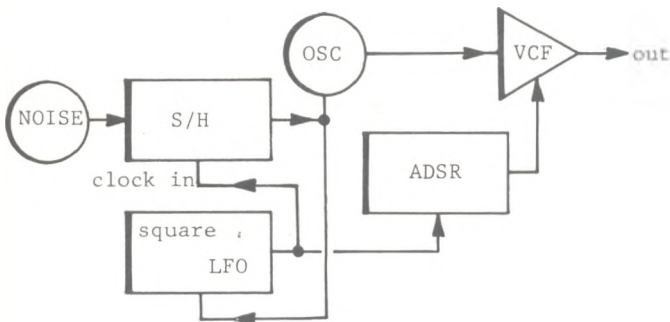

Figure 7: Syncopated Sample and Hold

Now, disconnect all the other modulation inputs to the LFO, so it's pulsing regularly again, and then hook the random stepped voltage output of the S/H back up to control the LFO (see figure 7). This will have an immediate and perceptible effect: The higher the random step, the faster the LFO will hurry to its next tick - and thus, the higher the note sounded by the tone oscillator, the shorter the note will be, while the lower the note, the longer it will last. This is a psycho-acoustically powerful patch, because the high/fast - low/slow priority is found in much of traditional music. Think how many sixteenth-notes the violins in an orchestra play, as opposed to how many the double basses play.

Now that you've heard this effect, hook the LFO's sine wave output back up to the same oscillator. If all goes well, it should begin to moan and hiccough in a positively eerie fashion.

The S/H is capable of some other tricks that you may find useful if you're tired of the same old synthesizer sounds. So far, we've only had it sampling noise to create a randomly stepped output. But if it has an appropriate patch point on the

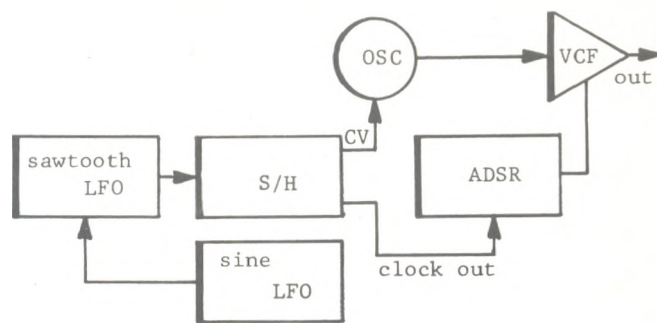

Figure 8: Sawtooth S/H with Evolving Phase

front panel, it can just as easily sample any other voltage we feed it. One of the most musically useful inputs turns out to be a sawtooth LFO. When the sawtooth is somewhat slower than the S/H clock (we're back to the normal regular-pulse clock ticking again now), the S/H output can feed a tone oscillator to create a scale-like staircase pattern. A sawtooth below 1 Hz and an S/H clock around 20 Hz will give us a flutelike flourish that has the advantage of not suggesting any specific tonality. Fed through an echo machine, such a flourish might be just the thing to lead into a higher-energy section of a piece.

As we speed the sawtooth LFO up, the steps of the staircase get further apart in pitch, and there are fewer of them in each rising (or falling) cycle (see related article in this issue - Ed). When the frequency of the sawtooth is less than twice the frequency of the clock, the staircase disappears, to be replaced by a phase interference pattern that is the aural equivalent of a moire pattern (or, a complex version of a Mozart alberti bass pattern). The finishing touch on this patch is to modulate the sawtooth LFO with a very slow sine wave LFO, causing it to change speed while the S/H clock stays steady (see figure 8). Now the alberti bass pattern, instead of repeating, will constantly shift, adding notes to make longer and longer arpeggios, then breaking into a microtonal scale that swoops down and back up, and so on. All by itself, the synthesizer is playing notes that seem to fall into meaningful patterns - though, as in the case of the "speaking" filter, it's the listener who creates the meaning by grouping or interpreting these sounds. I've always thought that three or four tracks of this kind of shifting pattern would be great for a fadeout on a fast, happy tune, but if you try it out, you might find some better use for it.

**Non-Imitative Percussive Techniques.** Just about any combination of oscillators, ring modulation, and noise can be fed into a filter with a cymbal-like envelope to create an ugly mechanical burst. Or you can leave the filter's initial level high enough that sound always comes through, and modulate it with a repeating envelope for a nerve-wracking machine drone.

For something not quite so bizarre, turn the resonance on a filter up until it almost feeds back, and use an LFO square or sawtooth wave as an audio (not a control) input to the filter. The sharp edge of the LFO wave will make an audible click, which the filter resonance will draw out into a kind of metallic tap or woodblock-like knock. Tune it by adjusting the filter cutoff frequency, and change



the rhythmic pattern by modulating the LFO. An LFO that has been randomized by modulation from the S/H (or three LFOs all modulating one another) makes a truly crazed percussionist. Alternatively, you could modulate the LFO you're listening to with another, slower square wave LFO. If you adjust the levels properly, the clicks will seem to be grouped as eighth-notes and triplets, because the LFO you're feeding through the filter will operate at two different speeds, one when the LFO modulating it is in the "up" portion of its cycle and the other when it's in the "down" portion. Be warned, however: Once in a while, this programmed percussionist will drop a beat, because the two LFOs won't be precisely synchronized.

Here's another idea: Use the square wave output from the second LFO (the one you're not lis-

tening to) to open and close the VCA, so that you'll get bursts of percussion followed by bursts of silence. Then take the sine or sawtooth output of this LFO and modulate the first LFO with it to make each burst of percussion change speed. Use a lot of sine or saw modulation in this patch, so the LFO going into the filter will rise from a slow clicking almost into the audio range before it's abruptly cut off. If all goes well, this patch should sound quite machine-like and ominous.

LFOs are also extremely useful for slowly altering the tone color of an ongoing event. Let's say you've set up a chord sequence on a three-stage, 16 step analog sequencer, with each stage controlling a different oscillator to give a sequence consisting of three note chords. The simplest patch is just to listen to all three oscillators all the time, but this can lead to aural fatigue pretty quickly. Fortunately, there are some easy solutions to this problem. You can route one of the oscillators through a VCA before it mixes with the other oscillators, and modulate the VCA with a slow sine or triangle wave, thus altering the amount of OSC 3 in the mix. If at the same time you use another LFO to modulate the waveform of OSC 2, and a third LFO to shift the cutoff frequency of the filter just slightly, while taking care to set these three LFOs at different speeds, your chord sequence will begin to take on a great deal of life. It will be hypnotically repeated and at the same time it will be continually varying in tone color, which paradoxically adds to the hypnotic effect.

As long as we're on the subject of sequencers, don't forget that a sequencer clock doesn't have to tick at a steady rate. With a three-stage sequencer, it's easy to use two of the stages to play pitches on the oscillators and the third to control the speed of a voltage-controlled clock. Syncopation and odd time signatures are one possible result. Even more intriguing is the possibility of setting up a riff whose metrical values are slightly off. On a digital sequencer, this is even easier to manage - just play something with a lurching syncopation, and hit the repeat button. You'll have a hypnotically repeating pattern that you can't quite tap your feet to, like a broken record. Improvising a solo over such a riff can lead your melodic thinking into entirely new areas.

**Applications.** We could go on listing patches, but the basic concepts should be clear by now. However, there's still the question of how to use these new sounds musically. While this could take another article in itself, here are a few random suggestions that you might find useful.

Synthesizers are so clean-sounding they sometimes don't blend in well with other instruments when recording. Echo will usually help this - or you might want to run the synthesizer through a guitar amp and mike the amp. Basically, anything that will introduce a touch of distortion and a physical quality to the tone will help a lot.

Concerning where to put effects in a piece of music, it's always a temptation with any new toy to use it everywhere you possibly can. But if you're not careful, your arrangement might end up sounding like a Christmas tree. The solution here is probably to treat the synthesizer the way you would any other supporting instrument. If it's an adjunct to the drum kit on a particular tune, listen to how the drummer is developing his or her part, and cue in your synthetic ratchet or cowbell at a point that

will make sense in conjunction with the snare drum and hi-hat. When a new section of the tune arrives, the drum part will usually change, and the synthesized percussion should change in response.

Like any other instrument, an effects synthesizer should be applied tastefully, with an awareness of how the whole arrangement fits together. Unless the effects are the focus of the tune, the synthesizer should probably be used for no more than three or four different types of events in any one tune. One of these events might be a major hook - a beeping that makes the chorus so unsettling, for example - while others might be purely supportive and very much in the background. The same principle applies to classical music synthesis; only the terms need to be changed. Synthesizer effects can be extremely complex and alien, or they can be very simple, but in either case it's important to remember that they aren't an end in themselves. They're a means to the end of creating good music.

When it comes to music that's played entirely on synthesizers, you obviously have more latitude for the lavish application of effects. But even here, you'll need to consider what the character of a given piece of music is, and which patches will further enhance that character. Is the mood insistent and urgent? Is it murky, misty and mysterious? Is it placid and pleasant? Each mood calls for different effects. In fact, a good exercise might be to decide on an emotional meaning first and then try to set up a patch to convey it.

In the last analysis, only a thorough familiarity with the capabilities of your own equipment will tell you how to achieve the effects you want; you may not have equipment comparable to what I used to set up the effects described in this article. But no matter how limited your equipment, by applying the principles I've outlined that equipment will probably be capable of more than you're using it for currently. So start messing with those knobs and switches. And don't forget to keep your ears open. **C**

## CONCLUSION

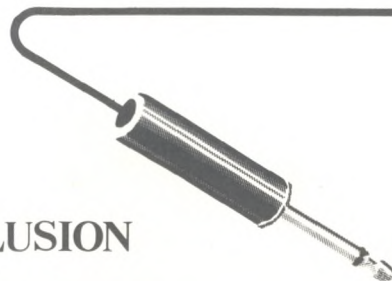

# EQUIPMENT EXCHANGE

List your equipment or services for sale, trade, or wanted, plus job openings, positions wanted, and so on. Keep listings brief; enclose \$1.00 for each 10 words. Prices, zip, and phone numbers count as one word each. Display classifieds are available for commercial ads; rates are \$12 per column inch (minimum, camera ready). Respond directly to the advertiser. Please don't write to POLYPHONY. Polyphony is not responsible for claims made in ads, or the results of any transactions. We reserve the right to edit or refuse any ads submitted.

## Services

Kits, parts, plans, help with modifications for synthesizers. Specials: 1. Convert your linear PAiA equipment to exponential with easy to use kit. 2. Precision VCO kits with exponential response. 3. Expand your PAiA 8700 microcomputer. For free info, write: Electronic Music Consultants, 533 San Blas Pl, Santa Barbara, CA 93111



announces  
exclusive U.S. distributorship of

## SYNTOVOX vocoder

imported from Holland  
3 models available  
address inquiries to:

EMSA  
269 Locust  
Northampton, MA 01060  
or call 413-586-3777

## Music equipment

Casio MT-30 keyboards, 3 octaves, 22 sounds, 8 note polyphonic. Self contained speaker/amp. Can run directly to amplifier. Weighs 6 lbs. \$235.00 Runs off 5 D-size batteries or Casio adapter \$15.00 Send money order, cashiers check, or cash.O.D. SOUND ELECTRA, P.O. Box 17206, Minneapolis, Minnesota 55417 (612) 727-1482

Expanded P-4700/J, factory assembled, 1K RAM, MUS-1, 4 VCO, 2 VCR, 3 ADSR, 1 Reverb, 1 LFO, 1 Mixer, 2 Balanced Modulators, 2 Transposers, 1 Multiple/Attenuator Panel, 2 Pedals, 2 Extra wing cabinets, cassette and software, cords, manuals. Excellent condition \$1400.00 invested, \$800.00 or best offer. No reasonable offer refused! Ron Slabe, 26351 Lakeshore Blvd., Euclid, Ohio 44132 (216) 261-1072 after 8pm.

## equipment

PAiA complete 8782 keyboard, cassette interface, 4 cassettes, 2700 keyboard with glide, 8781, 8780, 4761, 4712, 4780, two 4770A, 4730, two 4740, 4711, two 2720-3B, 2720-9, 27203L, four 27202A, two 2720-11, 2720-5, three 2720, 2720-12, 2720-7, 2720-14, patch cords and all documentation \$600 or separate. Hohner Clavinet E-6 like new \$525. Hammond L-112 organ with percussion, chopped, \$295. Farfisa 5 octave combo organ, vintage sound \$110. Fender Vibro Champ guitar amp, like new \$75. Electro-Harmonix micro synthesizer for guitar \$110. Electro-Harmonix full double tracking effect \$45. Electro-Harmonix talking pedal and attack equalizer \$45. PAiA Phlanger, Infinity Plus Sustain, Proteus books and cassette, Blacet tunable drum \$75. All items may be sold separate, combined, or by best offer. Dave Mettle, 1075 Beechwood Rd., Columbus, Ohio 43227 or phone 614-235-0716

**The Phasefilter™**  
Timbre  
Modulator  
Subtle  
Excitement  
for Synth!

- ☆ 4 Electronic Switched Phase and Filter Combos
- ☆ DPG Function Generator
- ☆ LED Bar Graph
- ☆ SSM VCF—Lo Noise, Distortion
- ☆ Complete Kit: \$129. CA, add 6%
- Free Shipping! MC/VISA OK

BLACET MUSIC RESEARCH, 18405  
OMRR, GUERNEVILLE, CA 95446

Korg PS-3100 polyphonic patchable synthesizer. Totally separate events (rise and fall times) per each 48 keys. A rare and versatile instrument, \$1900.00 Will accept in part trade; synthi AKS, Serge equipment or ? Walt Whitney, 2232 Wengler, Overland, MO 63114 (314) 429-2858

Hammond B3 Organ with Leslie RV122 tone cabinet, Polymoog synthesizer with pedals and case, all in top condition, no road use, reasonably priced. Enid, OK 405-234-3589

## Job Openings

PROPHET-5 SYNTHESIZER TECHS NEEDED NOW!!!

Sequential Circuits is looking for experienced techs who've built their own synthesizers and can trouble-shoot to component level (digital and analog). Send your resume to Harrison Thomas, Sequential Circuits Inc., 3051 N. 1st St., San Jose, CA 95134. For more information call (408) 946-5240

## Wanted

1979 Solid State Microtechnology Data book and any SOLD OUT issues of Polyphony. If you want to sell drop me a postcard. John Russo, 90 Howard St., Irvington, N.J. 07111

## Equipment

360 Systems Slavedriver for Bass Guitar/Synthesizer/Interface with pickup/footpedal/cords \$350.00, call MARK 1-203-442-1550.

ARP 2600, modified. Moog bend and patchable modulation wheels, 30 foot cable with dependable connector, rocker glide switch. Best offer. Mark Bahoric, 1328 Bingham Dr., Fayetteville, N.C. 28304 (919) 425-8270

For Sale: OB-1 Oberheim synthesizer, CR-78 Compu Rythum, Hohner Electric Piano/Harpsichord. Whole package \$2200. (305) 857-0908 after 8pm Eastern time.

**BLACET DFD**

☆ **SPECIAL** ☆

**ON OUR FAMOUS DIGITAL FREQUENCY DIVIDER**  
\$39 (Reg. \$52)

- ☆ Classic Fat Sound
- ☆ Divide by 1 thru 3 and 4 thru 4096 available separately.
- ☆ Mixer/LP Filter
- ☆ Reset
- ☆ Easy Kit. (Does not include front panel)

Add \$2 P&H US, Canada, Mexico; \$5 Elsewhere. CA, add 6%. MC/VISA OK

BLACET MUSIC RESEARCH, 18405  
OMRR, GUERNEVILLE, CA 95446



# Play a turkey.

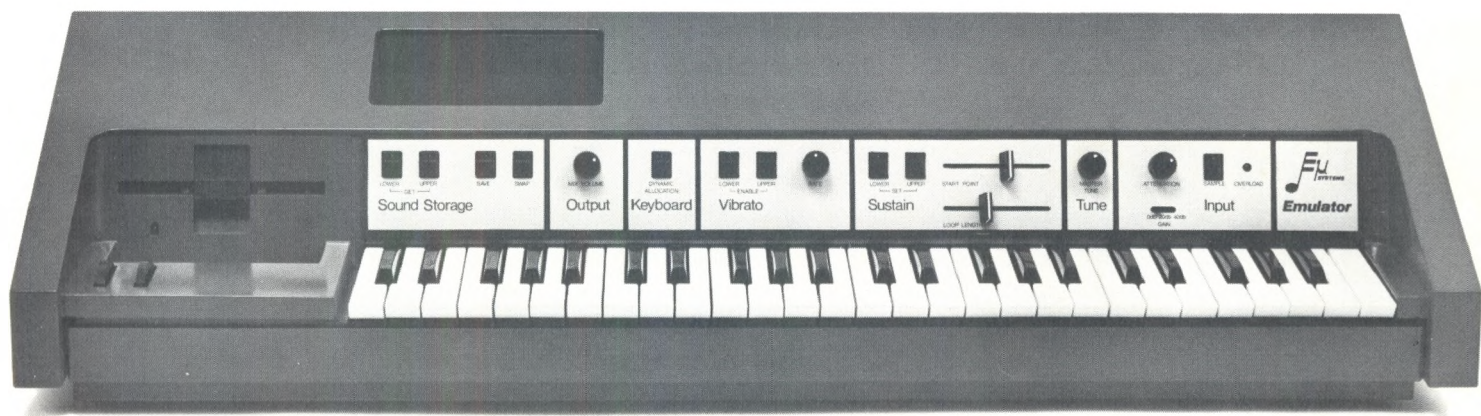

Or a dog. Or violins, drums, voices, sound effects, machines, or, in fact, anything. Not synthesized simulations but the actual sounds. With the E-mu Systems Emulator, *any* sound you can hear can be digitally recorded and then played back at any pitch over the range of its keyboard—with up to eight note polyphonic capability. Instantly.

The Emulator opens up a new world of possibilities to composers, performers, studio engineers and sound effects designers. Among its features are a split keyboard (for the simultaneous control of two independent sounds), realtime effects wheels for vibrato and pitchbend, a built-in disk drive for unlimited sound storage, and an optional multitrack sequencer for the creation of complex polyphonic

textures. All in a compact, portable instrument that is incredibly simple to use and priced within the budget of most serious musicians.

But talk is cheap. The world is suddenly full of digital instruments offering incredible features (at incredible prices). You can hear the Emulator soon at selected music stores. Listen to it. Compare its capabilities, ease of use, and price. We think the choice will be obvious. After all, you want to be able to play a turkey.

Not buy one.

## **E-mu Systems, Inc.**

417 Broadway, Santa Cruz, CA 95060  
(408) 429-9147





**PAiA**

**Effects**  
**Keyboards**  
**Synthesizers**  
**Computer control**  
**Studio electronics**

**PROTEUS I**

*This is what our  
newest catalog looks like!  
Get your free copy by sending us  
the coupon from our ad on page 25.*

the new generation from

**PAiA Electronics, Inc.**

1020 W. Wilshire Blvd., Oklahoma City, OK 73116 - (405)843-9626