

# **Polyphony**<sup>T.M.</sup>

\$2.50

***ELECTRONICS-MUSIC-HOME RECORDING***

*April 1983*

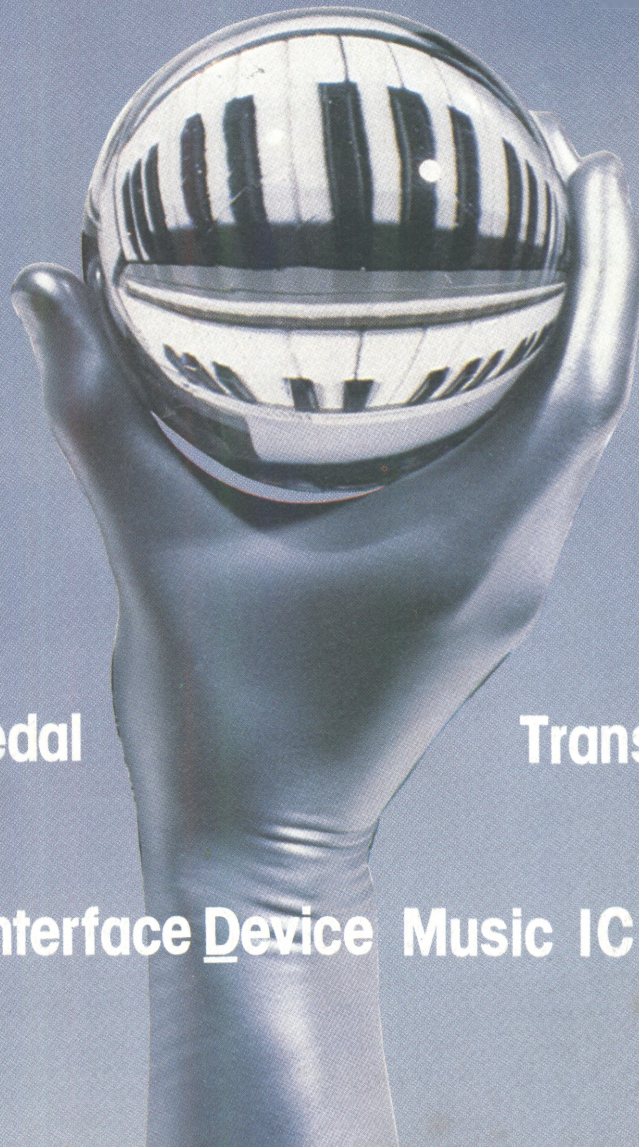

**Build a Bass Pedal**

**Transversal Filters**

**Sound Interface Device Music IC Details**

*ISSN: 0163-4534*

# PAIA STOMP BOX EFFECTS

AT LOWER THAN 1980 PRICES

These new stomp boxes from PAIA are designed to give electronic guitarists the highest quality effect at the lowest possible price. Cases are formed of heavy steel and covered with the most scuff-resistant baked-on finish available. All feature heavy duty switches for long life and electronic effect switching for pop-free punch-in and punch-out. All are high input impedance, low output impedance, non-inverting, low noise devices designed to meet all proposed FX standards. Each provides hour after hour of operation from a single 9 volt battery and provide automatic power switching; you'll never have to worry about forgetting to turn them off.

## HOT LYX SUSTAIN

Probably the most used effect by any electronic guitarist, a sustain unit is essentially an amplifier that automatically increases its gain to compensate for a guitar's normal decay characteristics. The result is the ability to hold notes and chords much longer than would otherwise be possible.

Hot Lyx gives you all the control you need, continuously variable sustain from just enough to make your Silvertone sound like a Les Paul to "pedal to the metal" controlled feed-back settings that give rock-guitar its "all-out" quality. Level control allows for either lower or higher volume levels when you're punched into the effect and can also be used as an over-drive control to give you the sweetest fuzz/sustain sounds you've ever heard.

No. 5710 HOT LYX Sustain . . . . . \$34.95 (3 lbs.)

## MIDRANGER™ Midrange Equalizer

Sure, your amp has bass and treble controls — but what about the all important midrange? When you need more sound from your axe than most amps can give, but don't have the bucks for a fancy equalizer, the MID-RANGER is for you. Featured in Craig Anderton's June 1982 Guitar Player column, this special purpose equalizer gives more presence and "punch" by providing continuously variable boosts of up to 12 db. at switch selectable frequencies of 90, 200, 1000, 2000 or 4000 Hz.

Designed for guitars, voice, rhythm boxes and keyboards, the MIDRANGER features High Input/Low Output Impedance, quiet electronic switching and single 9v. battery supply (not included).

MIDRANGER (tm) Cat. No. 5740 . . . . . \$32.95 . . . . . 3 lbs.

## 5750 — AXE GRINDER(tm)

A classic fuzz to FX standards.

The AXE GRINDER might be a pretty routine fuzz if it weren't for a couple of subtle but significant features. Like a Distortion Intensity Knob that provides smooth control of clipping from just a hint when you really get it on to pure square waves when you even think of picking.

And the Distortion Tone, Distortion Level, and Clean Level controls are like having a built in mixer and E.Q., letting you precisely set the amount of distortion and its tone as well as the mix of clean and distorted signal. You probably never realized you could get so many sounds from a "simple" fuzz.

The AXE-GRINDER also features totally pop-free electronic switching and adherence to uniform FX standards that allow any Effect to work with any other without concern for mismatch noises or phase incoherence. 9 volt battery power (not supplied). 5750 Axe Grinder(tm) Kit . . . \$29.95 . . . . 3 lbs.

## 5760 ROCKTAVE DIVIDER(tm)

Whereas most effects that alter the harmonic content of a signal can only produce or accentuate frequencies higher than the fundamental frequency produced by the instrument, the ROCKTAVE DIVIDER fills out your sound by adding in wave-forms that are sub-harmonics of those produced by your axe.

Companor stages are used to stabilize input for reliable triggering of the divider circuitry and to impress the original dynamics of your playing onto the newly created subharmonics.

Independent level controls on the extracted fundamental and first and second sub-octaves allow you to produce just the mix you're after and master tone control lets you round the square wave sub-octaves off to near-sinusoidal purity.

The ROCKTAVE DIVIDER also features automatic power switching when in use, pop-free electronic cancel function and single 9 volt battery power source (battery not supplied). 5760 Rocktave Divider(tm) . . . . . \$39.95 . . . . 3 lbs.

ORDER TOLL FREE WITH VISA OR MASTERCARD  
1-800-654-8657

DIRECT MAIL ORDERS & INQUIRIES TO:

**PAIA Electronics, Inc.**

1020 W. Wilshire, Oklahoma City, OK 73116 - (405) 843-9626

QUALITY  
EFFECTS  
AFFORDABLE  
PRICES



# STAFF

**PUBLISHER**  
John S. Simonton, Jr.

**EDITOR**  
Craig Anderton

**MANAGING EDITOR**  
Linda Kay Brumfield

**TECHNICAL ILLUSTRATOR**

Caroline Wood

**CIRCULATION**  
Ramona French  
Peggy Walker

**BOOKEEPING**  
Cathi Boggs

**PRINT PRODUCTION**

Phuong Nguyen  
SEMCO Color Press

POLYPHONY (ISSN 0163-4534) is published bimonthly at 1020 W. Wilshire Blvd., Oklahoma City, OK 73116, by Polyphony Publishing Co. Entire contents copyright (c) 1982 by Polyphony Publishing Co. All rights reserved. No portion of this publication may be reproduced in any manner without written permission from the publisher. Second Class postage is paid at Oklahoma City, OK 73125.

ADVERTISING rate card and deadline schedule is available upon request. Contact Linda Brumfield at (405) 842-5480.

DEALERS & DISTRIBUTORS bulk prices are available upon request. Contact Linda Brumfield at (405) 842-5480.

**SUBSCRIPTION rates:**  
American 1 year \$12.00  
2 years \$22.00  
Foreign 1 year \$14.00  
2 years \$26.00

We now accept MasterCard and Visa payment for subscriptions, back issues, and PolyMart items. Foreign payments must be by charge card, money order, or certified check in US funds drawn on a US bank.

BACK ISSUES are available at \$2.50 each ppd. Send SASE and request our 'Back Issue List' for a complete index of issues and their features, or see the back issue ad in this issue.

CHANGE OF ADDRESS notifications must include your former address and zip code, and any numbers from the mailing label, as well as your new address. When you move, be sure to notify your post office that you DO want second class and controlled circulation publications forwarded. This will save lost or returned issues. Polyphony is not responsible for replacement of lost or returned issues when we have not been supplied with change of address information.

TO POSTMASTER, send address changes to:

POLYPHONY  
PO Box 20305  
Oklahoma City, OK 73156  
Ph. (405) 842-5480

# CONTENTS

ISSN: 0163-4534

## Polyphony

VOLUME 8, NUMBER 3  
APRIL, 1983

### FEATURES

Build A Bass Pedal System .....	17
By: Stefan Hawk	
Dr. Rhythm Modification .....	29
By: Craig Anderton	
Meet SID Sound Interface Device .....	33
By: James Lisowski	
Switched Capacitance/Transversal Filters .....	12
By: George Quiroga	
The Rockman Cometh! .....	10
By: Kirk Austin	
Voltage Controlled LFO .....	36
By: Craig Anderton	
Voyetra Eight Review .....	8
By: Mark Styles	
Sources in Acoustics .....	30
By: David Doty	

### COLUMNS

<b>DETAILS:</b> The Audio Connection	
by: Dennis Bohn .....	16
<b>PRACTICAL CIRCUITRY:</b> Transistor Circuits	
by: Thomas Henry.....	26
<b>Re-View:</b>	
by: Robert Carlberg .....	6

### REGULARS

Ad Index .....	38
Current Events .....	23
Equipment Exchange .....	38
Letters .....	4

COVER PHOTOGRAPHY BY: Vesta Copestakes, CAVE Grafic

## WIND PLAYERS VOCALISTS

You can use your own instrument or voice to control any standard synthesizer, with more expressiveness than a keyboard.



### THE GENTLE ELECTRIC PITCH AND ENVELOPE FOLLOWER

Write for our free detailed brochure, patch diagrams, and application notes.

Also available as modules for Aries and Serge synthesizers, or as circuit boards for custom systems. Dealers inquiries welcome.

*gentle electric*

Dept P  
P.O. Box 132, Delta, CO 81416  
(303) 874-7171

## ELECTRONIC PROJECTS FOR MUSICIANS

Project kits now available exclusively from PAIA and for a limited time at a special "10% off" sale price

Proj #	Title	Regular Price	Sale Price
1	Preamp (less XLR and VU)	\$22.95	\$20.65
2	Metronome	\$19.95	\$17.94
3	Passive Tone Control	\$16.95	\$15.25
4	Headphone Amp.	\$19.95	\$17.95
5	Mini-Amp	\$29.95	\$26.95
6	Ultra-Fuzz	\$19.95	\$17.95
7	Bass-Fuzz	\$21.95	\$19.65
8	Compressor/Limiter	\$27.95	\$25.25
9	Ring Modulator	\$29.95	\$26.95
10	Dual Filter Voicing Unit	\$29.95	\$26.95
13	Bipolar AC Adapter	\$34.95	\$31.45
14	Treble Booster	\$12.95	\$11.65
15	Electronic Footswitch	\$19.95	\$17.95
16	Tuning Standard	\$39.95	\$35.95
17	Super Tone Control	\$29.95	\$26.95
18	8 in. 1 out Mixer (less XLR)	\$18.98	\$26.06
20	Practice Play Along	\$24.95	\$22.45
21	Phase Shifter	\$51.95	\$49.45
24	Tube Sound Fuzz	\$24.95	\$20.65
25	Envelope Follower	\$26.95	\$24.25
26	Spluffer (less optional parts)	\$14.95	\$13.45
27	Noise Gate	\$32.95	\$29.65

ADD \$3.00 POSTAGE AND HANDLING WITH YOUR ORDER.

These are kits of parts and circuit board only, to allow maximum flexibility in their application no cases or enclosure are included. Instructions for the assembly of each item are part of the book *Electronics Projects For Musicians* (\$14.95 plus \$1.00 postage) and are not duplicated with the kit.

CHARGE TO VISA OR MC TOLL-FREE  
1-800-654-8657 9AM to 5PM CST MON-FRI

DIRECT INQUIRIES TO:

**PAIA Electronics, Inc.**

1020 W. Wilshire, Oklahoma City, OK 73116 · (405) 843-9626

# Letters

## CALLING ALL SYNTHS

I have been evaluating various synthesizer kits for about two years, and finally decided on the RMS ARIES. I estimate it will take me two to three years and about \$4,000 to complete the system.

Recently, I called RMS and unfortunately found out that no new development is being done on the ARIES line and that all orders for ARIES modules are considered custom orders. I wonder if RMS will offer ARIES modules for the next three months, let alone three years. I've noticed that RMS has not advertised in *Polyphony* for quite some time now, is that some indication of their stance in the synthesizer business?

I'm looking for alternatives. I never gave PAIA modules much consideration, I am ashamed to admit, because they don't seem to have that "professional" look that ARIES has. If you can give me a good pep talk on the qualities of a PAIA system, I'd really appreciate.

Allen Hoeltje  
Boulder, CO

Allan -- Ah yes, we certainly handle the tough questions around here! The Aries is more or less a "dead issue"; the original company went out of business, and Ron Rivera is essentially supporting it as a service to existing owners. I find it completely understandable that he's not going to put any more time and effort into it than he is currently.

As far as not advertising in *Polyphony*, don't be too hard on RMS. Occasionally, people who are otherwise intelligent and aware have unexplained lapses of judgment, and fail to advertise in *Polyphony*. Luckily, Linda Kay (our managing editor) is doing her best to help these people so that they may once more regain their status as respected members of the electro-musical community.

Re PAIA, their 4700 series

modular synthesizer is an extremely cost-effective system which allows experimenters to make sounds they would never be able to otherwise afford. It is also a quite versatile system (see David Vosh's letter below). I use PAIA keyboards myself, but overall I would say the 4700 series equipment is not quite as sophisticated as what you appear to be contemplating.

From the tone of your letter, I feel you will be most satisfied by a synthesizer that you build yourself. It's not that hard, especially if you take it one module at a time. The PAIA EKx series kits are excellent for providing the basic VCO-VCF-VCA-VCEG functions, CES and SSM offer evaluation boards for their music chips, and of course, both *Polyphony* and *Electronotes* (1 Pheasant Lane, Ithaca, NY 14850) have published many synthesizer circuits (check out some of Thomas Henry's modules in recent issues, for example -- they're pro-spec and inexpensive), as well as the Barry Klein book advertised in *Polymart*. Really, doing it yourself isn't that much harder than building from a kit, and you'll end up with a synth which fits your needs exactly.

So there's your pep talk. Warm up your soldering iron and go to it!

## HISSAWAY

Radio Shack is now stocking the NE572 compander chip, which is described as being "intended for noise reduction in high quality audio systems". I have enjoyed your columns in *Keyboard* and *Guitar Player* for several years, and I feel that a refined version of the 572 circuit given with Radio Shack's parts data would greatly serve the many readers of your columns and books. If you know of any applicable circuits, I would greatly appreciate your suggestions.

Robert MacArthur  
Iowa City, IA

Robert -- The 572 is still a relatively recent chip and not that many circuits including it have been published. However, it does seem good for noise reduction (among other things) and if I ever get any spare time, I definitely want to check it out for several circuits I have in mind. In the meantime, do any readers out there have any good noise reduction circuits based on the 572? You know where to send them.

#### INVOKING THE MUSE...

I have two Muse binary sequencers in need of repair. These were made by Triadex, which is long since out of business. Can any readers provide schematics or troubleshooting tips? I really think they're great little devices and would very much like to get them fixed.

Art Noel  
Box 913  
Havertown, PA 19083

#### MURPHY'S LAW CONFIRMED!

I have just attempted to build Jacques Boileau's Analog Delay Clock Modulation project (March/April '82). Upon closer inspection I found the pinout of the TL084 does not match the pin designations for inverting and non-inverting inputs for IC2, 3, and 4. All four op amps are configured in the non-inverting mode according to the figure 2 diagram on page 27.

Please pass this along to your readers so they don't get too frustrated building the thing.

T. Figueiredo  
San Francisco, CA

#### SYNC OR SWIM, CONTINUED

I really enjoyed Craig's articles in the 1/83 and 2/83 issues of Keyboard magazine on synchronization, and here's a tip on doing sync with PAIA equipment. I'm using a PAIA 8700 system (micro-computer, encoded keyboard, cassette interface, linear D/A, 2X Quash, dual digitizer) and have been able to use the SEQUE 1 program to create timing pulse tracks. By entering "notes" (combination of a "pitch" CV and a gate) using the score or event modes, it is possible to create

any sort of regular or irregular pulse train. I've been using these to clock analog sequencers, sample and holds, and electronic switches. The tempo up/down, single play, repeat play, and tape load/save pads have all provided useful variations to the basic idea. For example, tape load/save allows you to store your timing data on a cassette machine for future uses so as to not eat up tracks on your big machine for storage. Using the single/repeat mode gives easy flourishes or ostinato effects. Of course, the tempo up/down pads control the relative speed of the timing pulse data. One thing I haven't been able to try is using it with a programmable, syncable device a la TR-808, TR-606, etc. as I do not own any of these devices. Admittedly, this approach isn't as elegant or versatile as the "Master Synchronizer" presented in the Keyboard articles, but I've had a lot of fun with it and it has allowed me to exert more detailed control over synchronized sounds in my recent experiments and pieces.

The click and sync pads on the 8700 (running SEQUE 1) are also very useful as detailed by John Simonton in "Friendly Stories about Computers/Synthesizers". One idea I haven't looked into would be to add some code to SEQUE 1 which would allow you to program a variable click track rate. Then, the 8700 could provide timing pulse control data directly at its cassette output (just as the current fixed rate click track does). Or, if the "metronome" rate could be made variable it might serve as well for the purpose.

David Vosh  
Upper Marlboro, MD

#### SOLO/MUTE UPDATE

I've recently made a number of improvements to the Solo/Mute circuit presented in the Sept/Oct 1982 issue of Polyphony, listed in the order of importance:

1. I increased the cutoff voltage at the control points by changing the Zener diodes from 7.5 to 12V. I was having problems with the unit passing transients during loud musical passages, and this took care of the problem.
2. I dropped the resistor

.....continued on page 7

## Adopt This Mean Little Kit

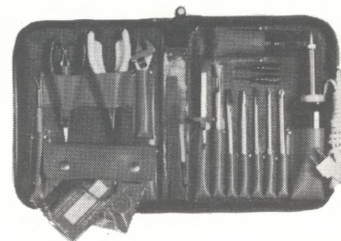

Take home this 24-piece kit of electronic tools designed for engineers, scientists, technicians, students. Includes 7 screwdrivers, adjustable wrench, 2 pair pliers, wire stripper, knife, alignment tool, stainless rule, hex key set, scissors, 2 flexible files, burnisher, soldering iron, solder aid, coil of solder, and desoldering braid. Highest quality padded zipper case measures approximately 6 x 9 x 1-3/4" inside. Satisfaction guaranteed. Send check, company purchase order or charge VISA or Mastercharge. We pay the shipping charges to your door.

JTK-6 Tool Kit ..... \$95.00

### Free Catalog!

Page after page of hard-to-find precision tools. Also contains complete line of tool kits and tool cases. Send for your free copy today!

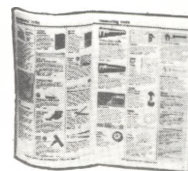

**JENSEN TOOLS INC.**

7815 South 46th St., Phoenix, AZ 85040  
Phone: 602-968-6241 TWX:910-950-0115

## Make your key-boards come alive with Veloci-touch™

It's ironic that while the electronics of your synthesizer is capable of subtlety of tone and color that are unprecedented in the history of music, you would be better off playing a typewriter for all the control of dynamics and expression you have from the keyboard. Now you can change that with PAIA's new Veloci-Touch Controller. This simple to build and install retro-fit for most electronic keyboards adds three important control parameters:

- **Second Touch Pressure** — pitch bends and vibrato the natural way.
- **Velocity** — as you play harder, output signal level increases.
- **Velocity Transient** — apply to filter or voltage controlled distortion device for dynamic timbral changes.

And best of all is the incredibly low cost. Retrofit versions are available from less than \$45.00. Stand-alone package with case and power supply (shown in the photo) less than \$70.00.

Get the full details from our latest catalog of electronic kits for stage and studio. It's yours FREE by calling:

1-800-654-8657

**PAIA Electronics, Inc.**

1020 W. Wilshire, Oklahoma City, OK 73116 - (405)843-9626

## UNIQUE VINYL

happily presents its first  
installment of fine recordings.

### FROM GERMANY:

the Pilz, Ohr, & Cosmic Music  
reissues, with original cover art  
and labels.

#### POPOL VUH - \$9

In Den Garten Pharaos  
Hosianna Mantra  
Seligpreisung  
Einsjager & Siebenjager  
Aguirre

#### MANUEL GOTTSCHING - \$9

Inventions for Electric Guitar

#### WITTHUSER & WESTRUPP - \$14

Live 68-73

#### BROSELMASCHINE - \$9

Live 68-73

#### EMTIDI - \$9

1st lp  
Saat

#### GURU GURU - \$9

Ufo  
Hinten

### JAPANESE POLYDOR:

these long-out-of-print lps  
are available on superb Japanese  
press: they feature *all* original  
artwork and lyric sheets and are  
on the *original* Polydor label.

#### FAUST, \$12.50

1st lp (black & white cover)  
So Far (with pictures)

#### LATTE E MIELE - \$12.50

Papillon  
(their best, fold-open  
with color insert)

#### ANTHONY MOORE

Pieces from the Cloudland Ballroom  
(Rec. in Faust's studio with  
Faust members)

#### SLAPP HAPPY - \$12.50

Sort Of  
(Original front and back cover,  
with Faust)

Please write for a free catalog.

### TO ORDER:

Please send money order, include  
\$2.50 for 1st lp and 50¢ each  
additional lp. All orders sent via UPS  
or 1st class mail.  
Phone orders are most welcome.

### UNIQUE VINYL

P.O. Box 23846 - Phoenix, AZ 85063  
602-247-1778

Robert Carlberg's

# re-view

Please note: The Sept/Oct '82  
column listed Philip Perkins'  
**Neighborhood with a Sky** incorrec-  
tly as **Neighborhood with a View**.

Prince **1999** (Warner Bros. 23720-  
1). Foregoing falsetto and many  
of his other soul trappings,  
Prince is making a strong bid for  
a rock crossover. Keyboard syn-  
thesizers, toe-tapping grooves,  
and unbridled hedonism are his  
means. As a double record it's  
too long, but at least it's priced  
like a single LP.

DEVO **Oh No! It's DEVO** (Warner  
Bros. 23741-1). If fame is mea-  
sured by how many people steal  
your stuff, then DEVO must be one  
of the biggest. Because of that,  
though, their trademarks are  
threatening to become anachron-  
isms, making it difficult to aban-  
don yourself to them.

Steve Winwood **Talking Back to the  
Night** (Island 9777). Both Prince  
and Winwood use modern technology  
to record all the parts them-  
selves, not for egocentric or  
economic reasons but because they  
can. This isn't his most inspired  
writing, but there's always a time  
for just good music.

Jean Piche **Heliograms** (Melbourne  
4045). Digital synthesizer digi-  
tally recorded playing gorgeous  
drones, Reichian pointillism, and  
sweeping brushstrokes of tonal  
color. It's very other-worldly,  
indicating there's a whole other  
culture in Canada besides Bob &  
Doug.

Electronic Art Ensemble **Inquiet-  
ude** (Gramavision 7003). By var-  
ying the density and using some  
non-electronics such as voice,  
organ, piano, guitar, and bass,  
the E. A. E. is able to make this  
improvisational electronic cater-  
wauling a fascinating experience.  
Lots of Zappa-esque tape speed  
tricks.

Eberhard Schoener **Meditation**  
(Kuckuck 059). A ten-year-old  
classic of atmospheric synthesis.

This 1982 reissue, after having  
been unavailable for several  
years, is a crystal-clear digital-  
ly remixed direct metal master  
pressing. It ranks with Tangerine  
Dream's "Atem" as the apex of the  
genre.

The **The Uncertain Smile** (Sire  
29878-0). A 3-song 12" EP with  
all the parts (synthesizers, gui-  
tar, bass, drums, flute, sax, and  
vocals) by one guy, Matt Johnson.  
It's remarkably accomplished, with  
several nice touches.

Roy Finch **Fiction Music** (POL  
0.11/2000). Pleasant electropop  
featuring rhythm box, controlled  
synthesis and Finch's restrained  
singing. Lyrically and musically  
Finch doesn't seem to have any  
particular axes to grind, showing  
a refreshing lack of pretense.

Gen Ken **Collaborations** (cas-  
sette). Heavily-electronic ex-  
plorations into uncharted dark  
continents, using combinations of  
rhythm box, white noise, basic  
synthesis, processed talking, and  
tape manipulations. The mood is  
generally fearless, as on his  
first tape (see May/August '82).  
\$6 from Ken Montgomery, 118 East  
4th Street #11, New York, NY  
10003.

David Ocker **Two Pieces by David  
Ocker** (cassette). One of the  
pieces is for Ocker's own over-  
dubbed clarinet, the other is for  
solo viola played by Roland Kato.  
Both seem essentially random and  
self-perpetuating. \$9 postpaid  
from Fun Music, 2315 Jackson  
Street, San Francisco, CA 94155.

Scott Fraser **Natural Histories**  
(cassette). Mostly long drones  
meant to sound synthetic but ac-  
tually made up of other sounds  
processed. Some fascinating  
transformations. \$8 postpaid from  
Fun Music (see above).

David Stout **All Known Rivers**  
(cassette). Gentle, peaceful  
soundscapes for synthesizer and  
tape, perhaps best likened to

"Music for Films" Eno or Kitaro's "Ten Kai". Most of it is exceedingly subtle and accomplished. Direct from Stout at 114 NW 30th, Corvallis, OR 97330.

Robb Murray **Classical Mosquito!** (e.p.). 8 neo-baroque pieces of organ-voiced synthesizer. Murray, more at home on a typewriter keyboard than the black and white variety, has deftly programmed his compositions to play themselves using an "Orchestra-80" program on a Radio Shack TRS-80. He's right -- "There's nothing eerie or esoteric about these pieces of music" -- just delightful organ miniatures with a modern twist. \$4 postpaid from Murray, 444 St. James Place, Chicago, IL 60414.

400 Blows **Beat the Devil** (Concrete 002; single). The spirit of Throbbing Gristle lives on -- mumbled talking, drone trumpet, pulsing bass, tapes, weird percussion. Nice joblads, but it's been done before. Concrete Productions, 47 Oak Avenue, Shirley, Croyden CRO 8EP, Surrey, England.

Steve Meehleder **The Collection** (cassette). Recorded "after work and on weekends", this tape epitomizes the grass roots electronic music explosion. Intricate textures and deliberate mixing take precedence over keyboard pyrotechnics, although the pieces have more than a passing classical influence a la Synergy & Vangelis. 1610 J Avenue NE, Cedar Rapids, IA.

Schaltkreis Wasserman **Psychotron** (Mercury 6367-042). Some sort of central timing source is used to synchronize synthesizers, electronic percussion, and arpeggiators. The result is tight-knit tunes with frequent key changes and counter-melodies. Swiss-citizens Daniela and Peter Wasserman also include some cut-and-splice tapework, a drone piece, and some singing (in German). There's more than enough variety and plenty of solid musical value.

Port Said **Eve of Departure** (cassette). Like their previous single (May/Aug '82) and cassette (February '83), this duo seems to delight in defying categorization. Unusual percussion and their own ways of using synthesizers make them sound unlike anyone else. You won't be tempted to dance to their music, but you'll marvel at

the unique tonalities. 132 West 24th Street, New York, NY 10011.

The View **In a Strange Land** (Videoview 444; e.p.). John Craig Blaine, who wrote, produced, sings, and plays guitar and synthesizer on these three tunes, is a talented guy. Not only does he wear a lot of hats, but the quality of the writing is easily as good as any of the techno-pop you hear on the radio. His bassist and drummer are pretty hot too. 99 East Street, Easthampton, MA 01027.

John Wiggins **Tuned Space** (cassette). More space than tunes, Wiggins explores the underbelly of Serge and Moog synthesizers. He avoids the usual pitfalls of abstract "art-music" by staying away from the obvious and emphasizing his incredible variety -- from tape manipulations to gated rhythms to computer music to quiet drones. 15 Reservoir Avenue, Northport, NY 11768.

Bill Nelson **The Love that Whirls (Diary of a Thinking Heart)** (PVC 101). The main disc is pop songs dressed in electronic clothes. Nelson's octave-jumping vocals draw you in, and the solid production holds you. A user-friendly disc. The bonus disc of instrumental incidental music to "Beauty and the Beast" probably loses something in translation -- short synthesizer settings are razor-cut together, giving a disjointed and, well, incidental overall impression.

Peter Schafer **Extension** (cassette); **Panta Rhei** (cassette). Co-founder with Rudiger Lorenz (May/Aug '82, February '83) of their SYNTAPE cassette label, this 20-year old West German shows what can happen when a synthesizer falls into the hands of a skilled keyboardist. He's got a classically-trained musician's interest in the way lines of notes interact, plus the synthesist's fascination with the tonal and expressive possibilities of the synthesizer. Carl-Ludwig-Schleich Strasse 5, 7518 Bretten, W. Germany.

Synarios **Uncontrolled Voltage** (cassette). A "live to tape" collaboration between Lauri Paisley and Don Slepian. A number of electronic keyboards are employed to create a lot of variety for a

.....continued on page 11



values on the positive side of each control point from 100k to 5.6k (!!). This runs both the Zener diodes and the 2N2222s in the switching part of the circuit much closer to their recommended operating limits. The result was a much more stable cutoff voltage at the control points, hence quieter switching glitches.

3. I determined the optimum operating voltage for the entire circuit to be 30V, and included an on-board LM317 regulated power supply. This was necessitated by the fact that I increased my phantom power to the industry standard of 48V, which pushed the circuit over the edge as far as a few of its design parameters were concerned.

I also have some comments about the last paragraph which was added to my original article. While FETs used as gate-controlled amplifiers are indeed prone to distortion, the situation here is a little different. The 0.01 uF cap between the source and gate of the FET makes the thing almost like a passive element throughout most of the audio range. I've checked this circuit out on a 'scope and find it to be linear within the limits of my equipment, eyes, and ears up to about 20 dBm. In any event, I use it in a cue or monitor mixing circuit which doesn't require the utmost fidelity. I don't really think you need to patch into the mixer system as shown in figure 2, especially if you are not using the circuit in the main signal path, and the most logical place for the circuit is as part of a cuing or monitoring system.

Lindsay Haisley  
Austin, TX

#### HELP!

For a book on Thaddeus Cahill and his Telharmonium (1892 - 1911), the first electronic music synthesizer, I would appreciate any information on letters, recordings, or other materials.

Reynold Weidenaar  
5 Jones St., Apt. 4  
New York, NY 10014

.....continued on page 11

# REVIEW

## Voyetra Eight

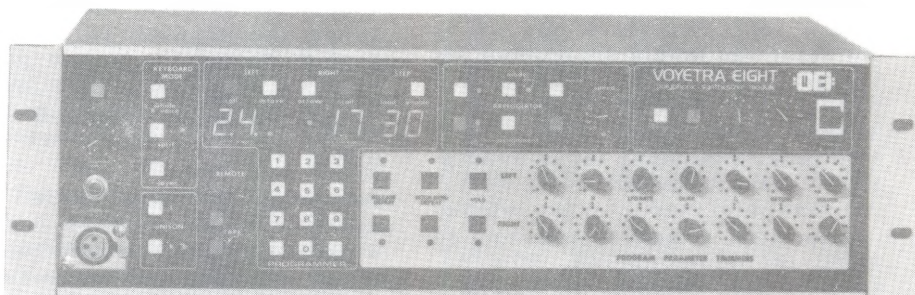

By: Mark Styles

From  
Octave Plateau  
Electronics

Octave-Plateau's Voyetra Eight is a multi-featured, eight voice polyphonic synthesizer. It comprises a modular approach, with a five octave keyboard and separate 19 inch rack mount mainframe (see photos); the circuitry is hybrid, containing both digital and analog circuitry. The VCOs, filters, and VCAs are analog while the LFOs, envelopes, and patching circuitry are digital. The signal output is very clean, and the extensive patching system allows you to create a wide variety of sounds. An autotune feature calibrates the oscillators, and if a voice cannot be brought into tune, it is shut off and a diagnostic error code results.

The Voyetra stores up to 52 patches, and includes a cassette interface for loading and storing patches. A 52 stage program stepper lets the user access the patches in any sequence via either the front panel, a footswitch, or the keyboard. Left, right, and mono outputs are available at the back of the unit; in addition, a second unit may be "slaved" to the first if desired.

The Voyetra is designed as two four voice synthesizers with an eight voice keyboard. Thus, there are four modes of operation available. These are:

- Whole eight mode -- Both synthesizers (left and right half) play the same patch.
- Split mode -- Each half of the instrument plays a different patch (you can define the split point).
- Layer mode -- The instrument and keyboard are in a four voice mode, but two different patches are playing simultaneously. This mode is great for creating a big sound, like having a brass and string section playing simultaneously.
- Unison mode -- This may be assigned to either half of the keyboard. All voices sound the

same note, giving a big fat sound not unlike the old minimoog sound.

On first glance, the front panel may appear confusing, but after a couple of sessions, creating a sound will become second nature. The calculator keypad labelled "Programmer" is the heart of the patching system. You address a patch by selecting the appropriate "Call" or "Enable" button (either the left synth, right synth, or the step function). Then, you use either the forward or reverse button, or specify two digits, to call up the particular patch you wish to play or modify.

While in the play mode, you can address 16 real-time functions -- envelope, filter cutoff, LFO rate, detune, etc. These are labelled "Program Parameter Trimmers" and temporarily alter the patch.

**Editing.** To edit a patch, you must press "Remote Edit" and "Autotune" simultaneously. The LED displays will now indicate which voice is being edited, which state or group of functions you are addressing, and the amount of modulation presently set. There are twelve states, and with each state the pots and buttons in the grey parameter section assume different functions. State 1 addresses the ADSRs, pulse width, filter tracking, and the volume of the VCOs. State 2 addresses the filter center frequency, Q, filter modulation, VCO tuning, LFO delay, and glide. States 3 and 4 select the waveforms of each of the two VCOs in each voice. The remaining states are labelled A-D and A'-D' (or "A prime" through "D prime"). These eight states represent four modulation banks. Think of each bank as a set of patch cords. You may select from eight modulation sources (DC, sample-and-hold, LFO sine, LFO square, VCO 1, VCO 2, ADSR 1, and ADSR 2). The



source is selected using the number on the keypad (only 0-7 will respond at this point). Each of these sources may be inverted if so desired. A destination is then selected with the appropriate button in the grey section (Q, filter center frequency, VCO1, or VCO 2).

By advancing the Stepper forward to the prime state, you can then select the amount of modulation and a controller through which you may send the modulation. The controllers available are +X and -X (on the joystick), filter cutoff pedal, keyboard pressure, keyboard velocity, noise, and ADSR 1. The controllers are selected again by the grey section buttons, and the amount of modulation by touching the keypad. This will add or subtract a given amount and be displayed by the Step LEDs.

In addition, you may also create patches using an Apple Computer which is connected either by the game paddle connector or a parallel port. In this mode, the Apple screen will reflect the Voyetra state and patches may be stored or called from the Apple's diskette and placed in the Voyetra memory (in any sequence). A future software package will allow an Apple/Voyetra system to compose and score music, as well as store sequences of notes.

**The Keyboard.** The five octave keyboard features a joystick controller and two stepper switches. These switches may step forward or backward through the patches. The joystick provides a pitch bend on the +Y and -Y parameters while the +X and -X are programmable for a number of functions. There is also a keyboard pressure and a pitch bend adjustment. The keyboard connects to the main unit with a standard Cannon (3-pin) connector.

Two features of the Voyetra not normally found in most systems are keyboard velocity and pressure. At first, you might not realize the subtleties involved with this system. Velocity is a voltage proportional to how quickly the key is depressed, while pressure is a voltage proportional to how much weight is applied to the keyboard. Once you experience this, you quickly adapt your technique to make use of these features. For instance, by inverting a DC source, using velocity as a controller, and controlling the filter frequency, you can close the filter by playing quickly and let it remain open by playing legato. You could just as easily set the pressure to trigger a vibrato, thus allowing you to emphasize different notes in different ways -- without taking your hands off the keyboard.

An optional expansion card, which plugs into an available slot in the mainframe, adds a number of features to the instrument including a parallel port and 128K or EPROM; so, you can expect future software enhancements as they become available. Current software additions are: 100 patch storage capability; two additional LFOs (with selectable waveforms); velocity controlled attack; keyboard controlled decay/release; more control over pulse width modulation; and expanded arpeggiation features.

**Conclusion.** The Voyetra combines the precision and "repeatability" of digital circuitry with the richness and economical advantages of analog circuitry. Since the operating system of the instrument is in software, modifications and updates are made by changing EPROMs and not hardware. While not exactly inexpensive (the list is approximately \$5,000), the Voyetra's design and craftsmanship will allow you to create sounds which are a notch above the competition. ●

# Not all Wireless Microphones are Created Equal



## This One Is A Telex

Recommendations by performers, as well as engineers, have made Telex the fastest growing wireless mic system in the industry.

Performers tell us they prefer Telex wireless mics because of the rich, full-bodied sound. And because the mics feel and look like conventional microphones.

To quote performers:...the Telex wireless mic sounds superior to any I've used for vocals—wired or wireless...  
...the freedom it gave our group sold me on the concept, and the sound sold me on Telex...

Audio and broadcast engineers stated that they prefer Telex because with just the addition of a second antenna, they have the most reliable diversity\* wireless mic receiver available, indoors or out. And because the compander circuitry provides dynamic range from a whisper to full fortissimo.

To quote engineers:...the Telex wireless is the best we've tested, and we've checked them all...  
...from a quarter mile, the signal was still crisp and clear...  
...for the money Telex outperformed all others we tried...

When you're ready for wireless mics, Telex offers you a choice of three VHF frequency groups, hand held or belt-pack transmitters, dynamic or electret microphones and a host of accessories. Compare our specs against any others, and by all means, compare the price. We're quite certain you'll also prefer Telex. Made in USA. Please write for full details.

\*US Patent No. 4293955 Other patents applied for.

### Quality Products for the Audio Professional



# TELEX®

TELEX COMMUNICATIONS, INC.

9600 Aldrich Ave. So., Minneapolis, MN 55420 U.S.A.  
Europe: Le Bonaparte—Office 711, Centre Affaires Paris-Nord, 93153 Le Blanc-Mesnil, France.

# The Rockman Cometh!

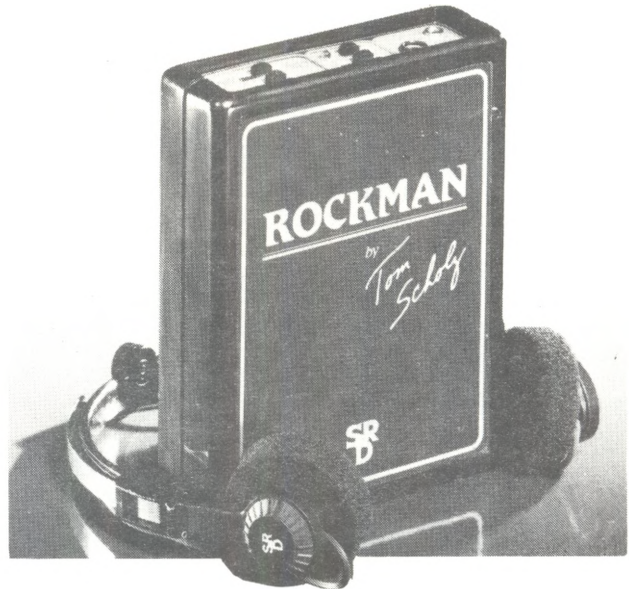

## A Product Review

By: Kirk Austin

I suppose that the premise of this review will be hard to believe for some of you, but I think that we are starting to see the beginning of the end of big stacks of tube amplifiers. The Rockman, manufactured by Scholz R & D, represents a significant breakthrough with respect to equipment for the professional guitarist. Running off of eight "AA" penlight cells or an AC adapter, the Rockman gives the musician more control over that elusive tube-overdrive sound, combines this with a built-in effects chain, and delivers all these sounds in a package small enough to fit in a guitar case! As if that weren't enough, it also drives stereo headphones (provided with the unit) for practicing without disturbing others. And when I say stereo, I mean STEREO -- it's a very big sound.

Perhaps the deciding factor in my decision to sell my Marshall amp and buy the Rockman was the fact that the sound of the Rockman is excellent for recording. The amount of outboard sound processing gear that the Rockman replaces is pretty remarkable: compression, tube-simulation, equalization, and chorus/delay. Since all of this is in one package and

designed to act as a system, the noise level is lower than when I use my separate processors. This also frees up a lot of my equipment for other use (like processing Thomas Henry's Snare+, which I'm also enjoying using).

Probably the most exciting thing about this product is the tube-overdrive simulator. I have always been a fan of tube amplifiers for guitar, and none of the solid-state circuits that I had heard really sounded like tube distortion to me. It seems that the critical portion of the sound is when it is decaying, since tube amps have a characteristic decay that is pretty hard to get with solid state devices. I was first convinced that "the sound" could be implemented with solid state devices when I heard Allan Holdsworth play through his new Hartley-Thompson amplifier about a year ago. Now it seems that Tom Scholz, the Rockman's inventor, has figured out how to do it also. In my experience, the Rockman is the best tube-overdrive simulator that I have ever heard. As the note fades away, it sounds just like a tube amplifier to my ears. Combining this overdrive effect with the chorus/delay results in a pretty impressive sound. To get a powerful sustaining tone -- previously only possible with a good deal of heavy, expensive, noisy equipment -- all I have to do is patch the Rockman into my mixer. I love it!

The Rockman provides four different sounds that can be selected with a four position slide switch. Two of these are "clean-sustain" type sounds that use compression techniques to give the guitar a ringing quality. It appears that the main difference between these two sounds is the equalization, since one of the tones is bright, while the second is more mellow in character. The remaining tone colors incorporate the "tube-overdrive" simulator; one of them is relatively mild and sounds a lot like my 1953 Fender Deluxe, while the remaining timbre can be compared to a Marshall stack type sound. All four of the basic timbres use the chorusing and delay circuits, although there is a switch to cancel those effects. The owner's manual indicates that tuning should be done with the chorusing turned off, so I can see why that switch is there. But, as soon as I cancel either one of those effects I realize how important it is to creating the total sound, and I immediately switch it back in.

In talking to people about the Rockman, I have heard complaints that there are not enough controls on it to vary the effects. However, I don't miss the half dozen or so knobs that would be necessary -- four great sounds at the flip of a single switch is much more desirable than a thousand mediocre sounds that take a good deal of thought and effort to achieve. In this sense, I think that Scholz R & D has done a great service to guitar players: Since

# re-view

it is now a simple matter to get good tone quality, we can concentrate on the more important (in my opinion) aspects of playing that come from the hands.

The other controls on the Rockman are a three position volume switch, and an input attenuator which is a screwdriver adjustment on the back of the unit. The input attenuator is nice, because it allows you to tailor the sensitivity of the compression and overdrive to the particular pickups in your guitar. The volume switch lets you match the output signal with the equipment that you are using. Most mixers like to see a standard line level, but "semi-pro" equipment like TEAC tape decks are set up for a signal level that is a nominal -10 dB.

The Rockman comes with a pair of lightweight headphones that are similar to those sold with personal stereos, and there are two output jacks so you can monitor on the phones at the same time you are going into a tape machine. There is also a stereo auxiliary input for playing along with records or with another Rockman.

I was impressed to find out that there is a two year parts and labor warranty that comes with the Rockman. I'm glad to see a company that stands behind a product. I think that this is a very good piece of equipment, and, considering the number of effects it replaces, is certainly reasonably priced. It is not, as some people would suggest, just a headphone amplifier for guitar; it is a sophisticated piece of signal processing gear that happens to be able to drive headphones.

Now, I'm not saying that everyone from Foreigner to Judas Priest will be running to their local music store to trade in their Marshall stacks for a Rockman. Things don't change that fast in the music industry. But, I am convinced that slowly we will see a change occur, and that in a few years solid-state amps will dominate the marketplace. It's going to be hard to convince some people, and I'm sure that a few people will never be convinced that solid-state can hack it no matter what the circumstances may be. But progress is being made, and the Rockman makes a strong case for solid-state guitar processing to replicate that "oldie but goodie" tube amp sound. ●

continued from page 7.....

two-piece, though the improvised nature of the pieces limits the amount of rhythmic and harmonic experimentation. \$7.95 from Don & Judy Records, PO Box 836, Edison, NJ 08818.

## Demo Records/Tapes

**The Incredible Sounds of The Synclavier II** (N.E.D. 1/2). A 12" LP of demonstration without narration. The sixty 20-second doodles are by Denny Jaeger, veteran of VISA, Levi, and Chevrolet commercials. He sticks mostly to the standard strings, organ, bells and harpsichord sounds with minor variations -- and the record really is blue.

**Just Fairlight #3** (cassette). Side A narrates how great this \$30K synthesizer is and provides short musical examples -- but little technical detail. Side B presents the same examples without narration. Considering the almost unlimited potential of this instrument, the conservatism of the examples is somewhat disappointing.

**The Emulator Demonstration Record** Five selections on an 8.5" flexi-disc, four of them presenting the usual rock, jazz, and classical sounds. The fifth is an ostentatious narrated demo produced by Australian composer Andrew Thomas Wilson which at least hints at the tremendous potential of an external-sound-recording synthesizer.

(Editor's Note: I recently asked Robert to compile a list of electronically-oriented records which have gotten better with age for those who are looking for good music they may have missed. Here are his choices.)

**Quiet Sun Mainstream** (Island HELP-19; originally released in 1975). Instrumental rock from veteran Phil Manzanera which quietly bores in on your consciousness. Subtle use of electronics and effects.

**This Heat This Heat** (Piano THIS-1; 1978). Turns rock inside out through extensive effects and processing. Bowled me over when I first heard it; it still does.

**Robert Wyatt Rock Bottom** (Virgin 13-112; 1974). Commemorating his stay in the hospital, this remains one of the most effective mood pieces ever released.

**Darryl Way Concerto for Electric Violin** (Island 9550; 1978). An original classical piece for clear plexiglas violin and "orchestra" -- amazingly synthesized by Francis Monkman.

**Claude Perraudin Mutation 24** (RCA 37070; 1979). One of the most strongly musical e.m. efforts ever released, with synthesizers, drums, bass, and guitar all played by Perraudin in his home studio.

**Wendy Carlos Walter Carlos' Clockwork Orange** (Columbia 31480; 1972). Not the movie soundtrack, but what Carlos would have done had she had the time to do it properly. Contains Carlos' best original writing to date (Tron included).

**Hatfield and the North Hatfield and the North** (Virgin 2008; 1973). Why can't all rock be this congenial?

**Weather Report Tale Spinnin'** (Columbia 33417; 1975). Every Weather Report album seems to get better with familiarity, but this one looms largest for its innovative mixing and synthesizer work.

**Harmonia Harmonia** (Brain 1044; 1974). Perhaps the most single-minded of the German hardcore electronics of the early '70s. At least until their second record.

**Brian Eno Another Green World** (Island 9351; 1975). The perfect blend of pure sound experimentation with tune-writing. Both have been explored further elsewhere but not together.

**Neu! Neu!** (Brain 1004; 1974) and **Neu! 2** (Brain 1028; 1973). The ideas, effects, and tapework are still tops in their field. I guess we haven't come that far in ten years.

**Happy the Man Happy the Man** (Arista 4120; 1977). Extreme

.....continued on page 31

# Switched-Capacitance Transversal Filters Theory & Practice

By: George Quiroga

## Theory

Two of the most recent advances in active filter technology are the "switched-capacitance" and "charge coupled device" filters. Both of these types of filters offer high accuracy, extended versatility, a minimum number of supporting hardware, and relatively low cost. This article examines and compares the principle of operation behind, and the application of, these new filter components.

**Switched-capacitor principles.** The simplest form of a switched capacitance filter can be derived from a standard passive low pass RC (resistance/capacitance) filter. In the RC filter, the cutoff frequency is determined by the equation  $f=1/RC$ . If we fix the value of the capacitance and vary the resistance, the frequency  $f$  can be controlled. Substituting the resistance  $R$  with a pair of Field Effect Transistors on either side of the capacitor creates the "switched capacitor" (see figure 1).

To show how this works, consider applying two complementary clock pulses on the gates of the FETs. When the gate of Q1 goes low, Q2 is high and the capacitor charges to value V1. Since Q2 presents a high impedance, there is no voltage at its output. When the clock changes state, Q1 shuts off and Q2 goes to a low impedance, thus discharging the capacitor to provide voltage V2. The circuit in figure 1 now reduces to the circuit in figure 2. The charge on the capacitor is  $Q=C(V2-V1)$ . If we divide both sides by the time it takes to flip the switch back and forth, the equation becomes  $Q/t=C(V2-V1)/t$ . Knowing that  $Q/t=I$  and  $1/t=f$ , we can further reduce it to  $I=C(V2-V1)f$ . Finally, applying Ohm's Law ( $R=V/I$ ) we obtain  $R=1/Cf$  where  $f$  is the clocking frequency applied to the two transistors. In essence we have a variable resistor whose value is dependent on the clock frequency.

We can now use this basic switched capacitor stage to replace the resistors in an active filter. Figure 3 shows this idea implemented in a basic low pass integrator. When used in an Integrated Circuit, the circuit of figure 3 is expanded to include four or more FETs (usually MOSFETs). The extra

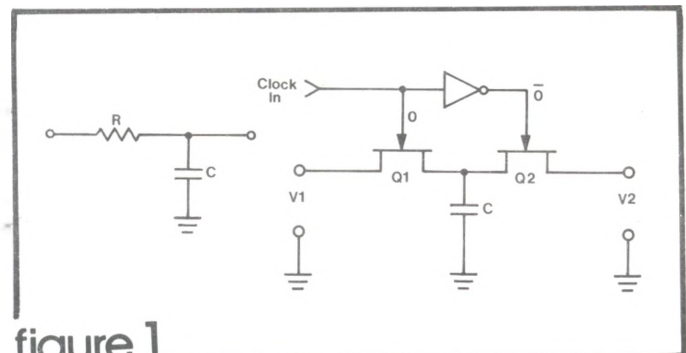

figure 1

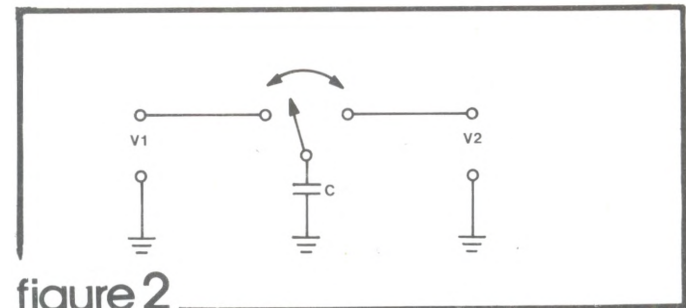

figure 2

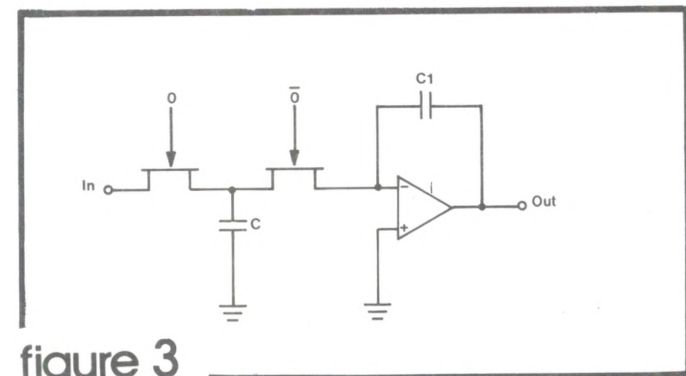

figure 3

components help to stabilize the integrator by reducing the amount of stray or parasitic capacitance inherent in the silicon substrate. Since MOSFETs take up very little space on the silicon, successful multistage filters can be produced. The advantage of this kind of filter is that the switched capacitor stage requires less area on the silicon than the equivalent resistor it is replacing. This fact is especially true for large resistance values. Therefore, the only limiting factor is the size of the capacitor that may be implemented on the silicon.

The switched-capacitor filter can be configured to provide multi-pole highpass, lowpass, bandpass, and notch filter responses. The frequency range, however, is presently limited from 0.5 Hz to 25 kHz. But since the dynamic range is greater than 80 dB and distortion is less than 0.1%, a switched-capacitor filter can be used in most audio applications<sup>1</sup>.

One problem common to any kind of clocked or sampled signal device is the appearance of the clock frequency at the output. In a switched-capacitance filter, this clock residue is about 6 mV. Another problem deals with the sampling frequency itself. To prevent any kind of aliasing distortion, the sampling frequency must be much greater than twice the input frequency.

**CCD transversal filters.** A charge coupled device stage is similar to the switched capacitor device, except that each FET has its own associated capacitor. This capacitor/FET combination makes up a storage cell or charge packet. By clocking a signal into this storage cell and clocking it out, one is essentially sampling the input. If each packet is connected in series and clocked in an alternating but sequential fashion, the initial charge sample is transferred down the line. Figure 4 shows a typical CCD configuration. Such a device is sometimes called a "bucket brigade" because it is analogous to the transfer of water buckets down a line of people<sup>2</sup>.

To make a filter from a CCD device, samples are tapped off of the delay line and each one is multiplied by a weighting factor. All of the weighted samples are then summed. The result is a signal which has been multiplied by a function and then integrated (figure 5). This process is the basis for Fourier and other transforms. By controlling the weighting functions electrically, a charge transfer correlator can be produced. This correlator is sometimes called a programmable transversal filter<sup>3</sup>.

A transversal filter may achieve lowpass and bandpass responses at frequencies from 1 kHz to 1 MHz, with a dynamic range better than 40 dB<sup>4</sup>. Distortion is equal to the switched capacitor filter. The main limitation of a transversal filter is its inferior high frequency response. The cause of this poor response is due to the sampling frequency, which must be fast enough to refresh the capacitors in order to minimize leakage losses. Therefore, transversal filters are not especially suited for most general audio applications.

**Conclusion.** Both switched-capacitor and transversal filters allow the circuit designer to implement a filter with an integrated circuit which requires very few external components. The only requirement is a stable external clock. For audio applications, the switched-capacitor has excellent specifications, and is lower in cost, when compared to a transversal type. Some types of switched-capacitor filters offer a digitally selectable res-

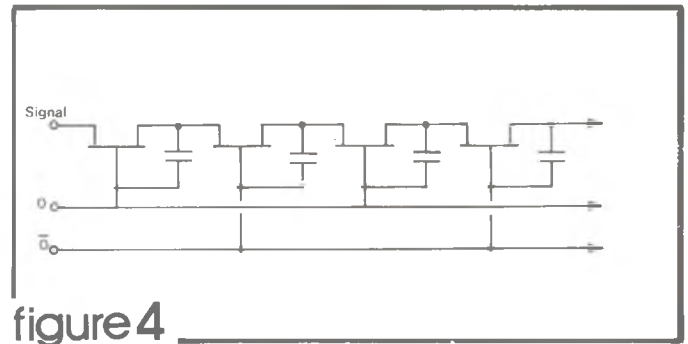

figure 4

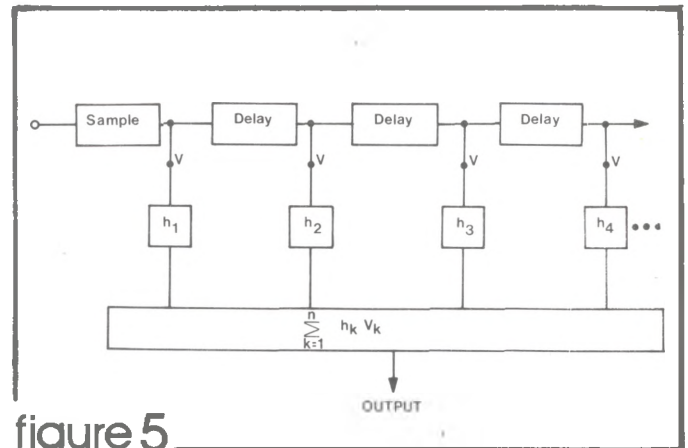

figure 5

onance ( $Q$ ) and center frequency. An example of this feature is found in Reticon's R5620 Universal Active Filter<sup>5</sup>. Programmable filters can be used in computer controlled networks for applications including spectrum analyzers, modems, and voice recognition systems.

1. Arthur Makosinski, "What's Inside Digital Filters", Radio-Electronics (May 1982): pp. 67-70.
2. A. G. Milnes, Semiconductor Devices and Integrated Electronics, (New York: Van Nostrand Reinhold Company: 1980): pp. 610-617.
3. Alan V. Oppenheim, ed., Applications of Digital Signal Processing, (New Jersey: Prentice Hall: 1978): pp. 129-140.
4. Reference 1, p. 69.
5. "R5620 Universal Active Filter", EG&G Reticon Preliminary Data Sheet, (Massachusetts: EG&G Corporation: 1982).

## Practice

EG&G Reticon of Sunnyvale, California manufacture several CCD and switched-capacitor filters. One of these, the R5620 Universal Active Filter, is especially suited for audio circuit design because of its low cost, accuracy, versatility, programmability, and simplicity in design implementation.

table 1

FILTER TYPE	LPIN	HPIN	BPIN
LOWPASS	V IN	GND	GND
HIGHPASS	GND	V IN	GND
BANDPASS	GND	GND	V IN
NOTCH	V IN	V IN	GND
ALL PASS	V IN	V IN	V IN
OSCILLATOR *	GND	GND	V OUT

\* Q MUST BE SET TO 11101

**Description.** According to the data sheet, "the Reticon R5620 is a double-poly NMOS switched capacitor universal active filter. It will perform all five filter types and a programmable oscillator without external components. Only an external clock is required." The R5620 has three signal inputs (HP, LP, and BP) which can be wired in different combinations to provide several filter types, including notch and phase equalization filters. As an example, a notch filter can be created by applying an input signal to both the LP and HP inputs. Figure 1 shows the pinouts for the R5620 and its basic configuration while Table 1 shows the pin connections for implementing the five filter functions and the oscillator.

To control the center frequency and the Q, there are ten digital inputs (five for "Q" and five for "FC") which are compatible with TTL or microprocessor levels. The five pins which are used to vary the center frequency will accept any five bit digital word and translate it to a ratio  $F \text{ clock} / FC$  from 50 to 200. Similarly, the Q can be made to vary from 0.57 to 150 in 32 steps. The 32 steps for frequency are logarithmically spaced which makes it suitable for audio applications. To calculate the 5 bit words needed to generate a particular response, Reticon supplies a look-up table in their data sheet. Tying all frequency control lines to ground results in  $F \text{ clock} / FC = 200$ , while tying them high results in  $F \text{ clock} / FC = 50$ . Tying the Q control lines low gives a Q of 0.57 and tying them high gives a Q of 150. Table 2 shows a partial listing of values and their corresponding control words.

Figure 2a shows a multipurpose filter for processing a guitar or synthesizer signal. When using a guitar, the guitar's output must be brought up to a level acceptable to the filter. The high gain preamp of figure 2b works very well for this purpose. (I use this preamp as a module in my synthesizer so that I can process any guitar signal through my synthesizer's mixer as well.)

table 2

Q	Q4	Q3	Q2	Q1	Q0
.57	0	0	0	0	0
1.05	0	0	1	1	0
3.0	0	1	1	0	1
10.0	1	0	1	0	0
40.0	1	1	1	0	1
150.0	1	1	1	1	1

FCLOCK/FC	F4	F3	F2	F1	F0
200	0	0	0	0	0
146.2	0	0	1	1	1
102.3	0	1	1	1	1
74.8	1	0	1	1	1
50.0	1	1	1	1	1

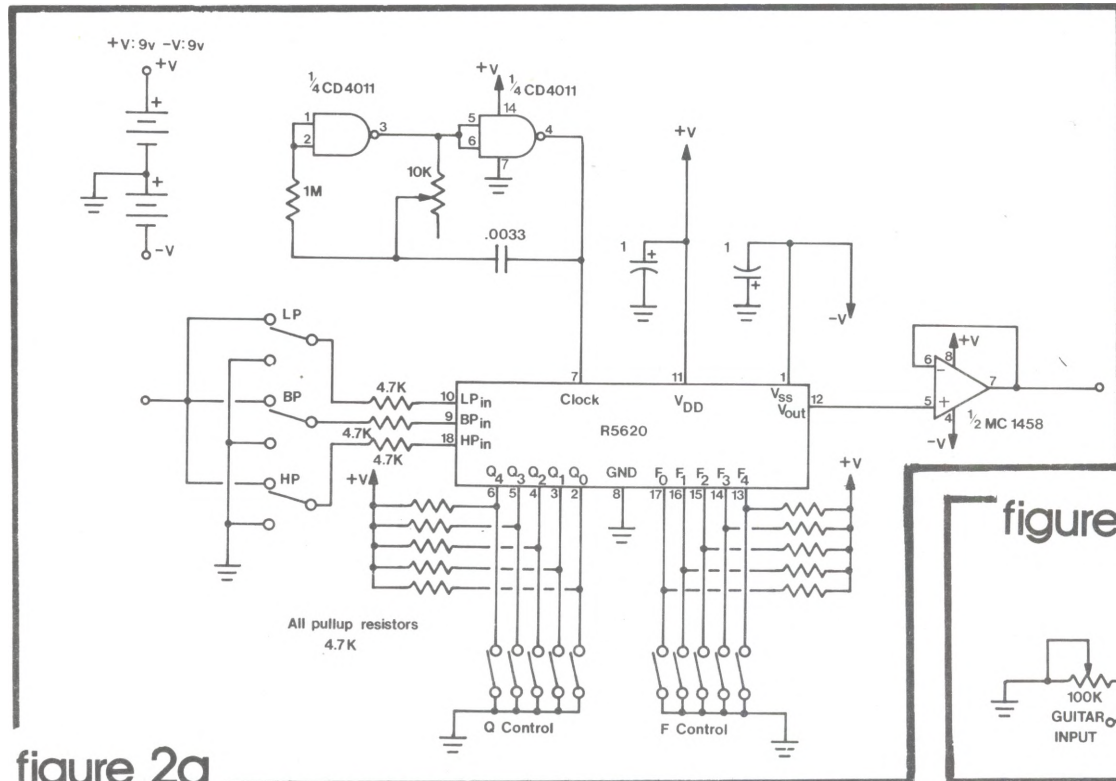

figure 2a

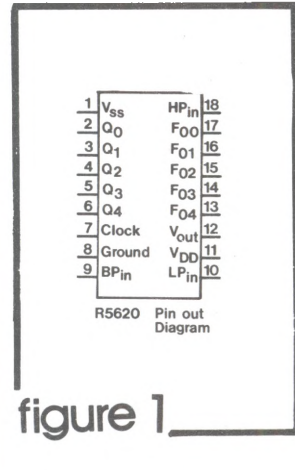

figure 1

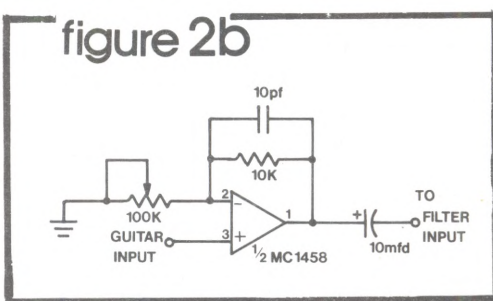

figure 2b

When constructing the multipurpose filter, I used DIP switches to set the Q and F control lines, but one may use switches mounted on a front panel for easier accessibility. Pull up resistors are a must on the control lines so these lines will be in either of two states and not floating; DIP resistor packs are useful for this function. The switches for the LP, BP, and HP inputs must have one side ties to ground when that particular input is not used. The op amp on the output is just a buffer to isolate the filter's output.

A simple clock oscillator made from a CMOS CD4011 quad NAND gate drives the filter's clock input. The CMOS gate also allows a pair of nine Volt batteries to power the entire circuit, making it very portable. For more advanced projects, you can use voltage controlled oscillators to provide the clock frequency. The frequency of the oscillator in figure 2a is determined by the 10k potentiometer and the 0.0033 uF capacitor. Table 3 gives possible filter ranges for particular clock frequencies. One should experiment with the potentiometer and capacitor values of the clock in order to come up with the right clock frequency for the desired range. The frequency of the clock is determined by the formula  $F_c = 1/RC$ .

Using R and C values of 10k and 0.0033 uF gives a clock frequency of approximately 30 kHz which provides a filter range of 150 to 600 Hz. Care must be taken to keep the clock frequency out of the audio range or else it will be heard at the output. Also, an input signal at greater than half the clock frequency may cause the R5620 to oscillate. The problem of having the clock frequency appear at the output can be minimized by using a lowpass filter with the corner frequency set slightly higher than the filter's highest passable frequency.

**Using the Multipurpose Filter.** Using the Multipurpose Filter is easy, but requires an initial calibration in order for it to be accurate. By using an oscilloscope or frequency counter, adjust the oscillator to provide the desired frequency range. A switch with 1% resistors may be used instead of the potentiometer to provide exact clock frequencies for several ranges. Once calibrated, the filter is ready for use. Select which type of filter you want by setting the appropriate input switches. Now select the correct corner frequency and Q by setting the appropriate controls switches, and you're ready to go.

Availability of the R5620, as of the time of this writing, is limited. A list of distributors may be obtained by writing to EG&G Reticon, 345 Potrero Ave., Sunnyvale, CA 94086. Although the retail price of the R5620 is a low \$7.50, Reticon requires a minimum \$100 purchase when ordering direct. Maybe there are a few dealers out there who would like to stock the R5620 and make it available to Polyphony readers.

Although I have limited this article to a relatively simple application, this is by no means the end. The purpose of this article is only to introduce you, the reader, to a low cost, state-of-the-art filter. The R5620 is a very versatile device and I'm sure many of you will be able to expand on the usefulness of this chip. Other applications include: synthesizer effects modules, equalizer and spectrum analysis stages, and speech synthesis systems. Finally, one must not overlook the idea of tying the R5620 to a microcomputer bus. This concept of digital control is where the R5620 really

FCLOCK	FO RANGE
10KHZ	50HZ-200HZ
20KHZ	100HZ-400HZ
30KHZ	150HZ-600HZ
40KHZ	200HZ-800HZ
50KHZ	250HZ-1000HZ
60KHZ	300HZ-1200HZ
70KHZ	350HZ-1400HZ
80KHZ	400HZ-1600HZ

table 3

excels. I am presently working on a programmable filter which uses a microprocessor to provide not only frequency and Q selection, but also phase shifting effects. I hope this to be the basis of a future article.

**Acknowledgement.** I would especially like to thank Reticon Corporation for their tremendous help; without it, this article would never have been possible.

**LARSEN  
MUSIC Co.**

We can supply you  
with equipment that gives  
meaning to the word

**PERFORMANCE**

**Roland &  
YAMAHA**

synthesizers are just part  
of a complete line of  
keyboard equipment  
we offer to the  
discriminating  
musician.



4001 N.W. 63rd STREET - P.O. BOX 32006  
OKLAHOMA CITY, OKLAHOMA 73123  
405-843-1573

# DETAILS

## The Audio Connection

by: **Dennis Bohn**  
V.P. Engineering, The Rane Corp.

Quality engineering necessitates standards, so this issue's "Details" describes connector standards which parallel international standards where applicable, and accepted practices elsewhere. After reading this, you need never be in the dark again regarding polarities or jack wiring. In general, we are a left-to-right, front-to-back, top-to-bottom society -- which has absolutely nothing to do with this article; it's just interesting.

**Connector conventions.** The single biggest source of wiring confusion in the pro audio industry is 3-pin connectors. Even their name is a source of confusion. Most commonly called "XLR" jacks, they are also known as "Cannon plugs", "3-pin connectors", "XLR-type" jacks, and "circular connectors". The name confusion makes sense, since this type of jack has never been given a generic title. Other connectors used in audio are commonly referred to as "phono" (originally called RCA jacks), or "phone" (1/4" jacks, after headphones and telephones -- their original usage), or "DIN" plugs (Deutsch Industry Norm), a German standards organization and European standard. Nothing comparable has caught on for 3-pin connectors, so they have become known by the original manufacturer's model number. The original manufacturer was ITT-Cannon and the model number was "XLR". Today, "XLR" is a

registered trademark of ITT-Cannon and cannot be legally used to describe any other manufacturer's version of this connector. And since very few people use ITT-Cannon XLR connectors, violation of their trademarked name is commonplace. Until something better comes along, we will refer to this type of jack as a "3-pin connector".

**3-pin connectors.** Much to many people's surprise there is a standard for wiring 3-pin connectors -- not two, as commonly believed. The conflicting so-called "European" and "American" standards are myths. There is one standard. It is IEC 268, (short for International Electrotechnical Commission Standard No. 268, part 12), and is titled "Circular Connectors for Broadcast and Similar Use". Created in 1975, signers to this international standard included Australia, Belgium, Canada, Denmark, Egypt, Hungary, Israel, Japan, the Netherlands, Norway, Romania, South Africa, Sweden, Switzerland, Turkey, the UK, and USA. In addition, the same convention was adopted separately in the UK as BS 5428 (British Standards Institution No. BS 5428, part 5, Section 3, 1980/81). There should be no conflict in connectors. There obviously is, and that is a sorry reflection of how badly informed are many manufacturers of pro audio equipment (another reason why they should read Polyphony to find out about stuff like this -- ed.).

The Rane Corporation wires its 3 and 5-pin connectors per IEC 268 as follows, and suggests that you do likewise in your projects:

### 3-Pin Connectors

Pin 1	Ground (shield, screen, etc.)
Pin 2	Positive (signal, hot, etc.)
Pin 3	Negative (return, common, etc.)

### 5-Pin Connectors

Pin 1	Ground
Pin 2	Left Positive
Pin 3	Left Negative
Pin 4	Right Positive
Pin 5	Right Negative

1/4" phone jacks. On Rane equipment outfitted with input/output phone jacks, the wiring convention for standard ring-tip-sleeve (RTS) connectors is:

### Stereo 1/4" Phone Jacks

Tip	Positive
Ring	Negative
Sleeve	Ground

### Mono 1/4" Jacks

Tip	Positive
Sleeve	Ground

For 1/4" RTS output jacks designed exclusively for headphone use, the standard is:

### Headphone Jacks

Tip	Left Positive
Ring	Right Positive
Sleeve	Common Ground

If you wire your connectors according to standards, and use a standard input/output structure (see previous "Details" columns on the Gozinda/Gozouta universal I/O stage), you'll be able to plug various devices together without having to worry about...details.



# Build a Bass Pedal System

By: Stefan Hawk

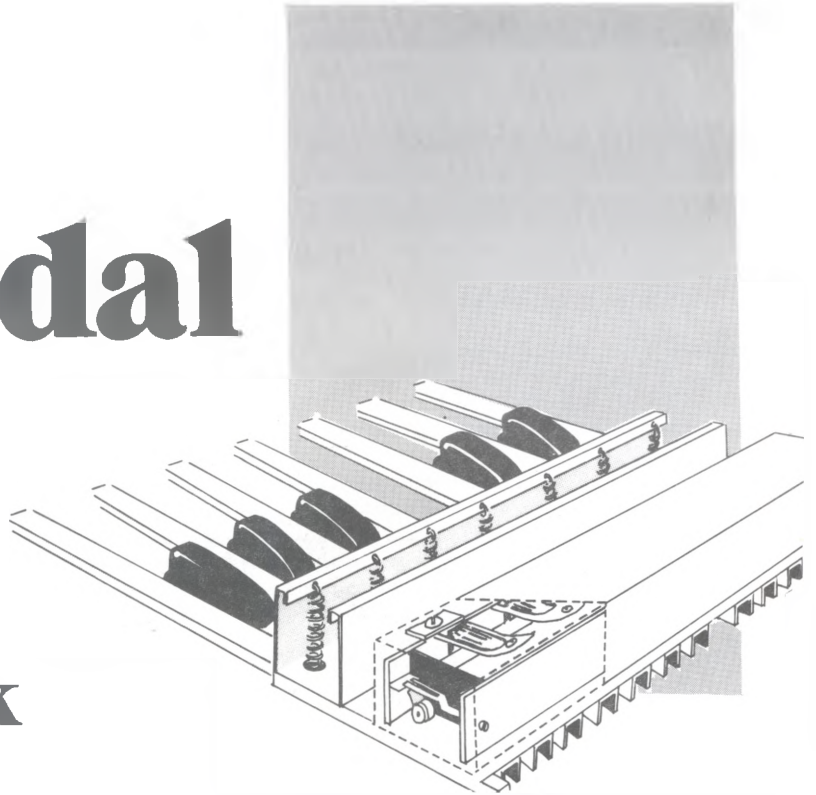

Here's a cost-effective set of bass pedals. This pedalboard setup will operate as a self-contained system and/or interface with a synthesizer. It contains a

monophonic tone generator chip, waveshaping circuitry, selectable footage, variable decay rate, percussive or sustain mode select, plus "raw" squarewave, gate, and

trigger output to interface with a synthesizer (the synth needs an external audio input for this application).

**How it works.** The heart of the system is the M-147B-1, a 13 bit latch pedal sustain IC made by SGS-ATES (an Italian-based manufacturer). It supplies 50% duty cycle squarewaves over five octaves simultaneously along with gate/trigger outputs. The outputs remain on until a pedal is released, and it has a left-hand priority when more than one pedal is depressed.

The circuit requires +15 Volts DC; you can supply power from your synthesizer or if you want to operate the pedals as a self-contained unit, use the power supply shown in figure 1. Current drain is small, so this supply is more than adequate even without a heatsink on the regulator.

Besides pedal switch contacts, a high frequency clock is needed to drive and tune the range of the M-147B-1. Figure 2 shows a CD4001 CMOS quad NOR gate acting as a high frequency clock with a pot to tune it to 500.06 kHz. The squarewave output isn't perfect, but is fine for this purpose. If you want to tune the pedals to different pitch sources, P1 should be a panel mount pot instead of a trimmer.

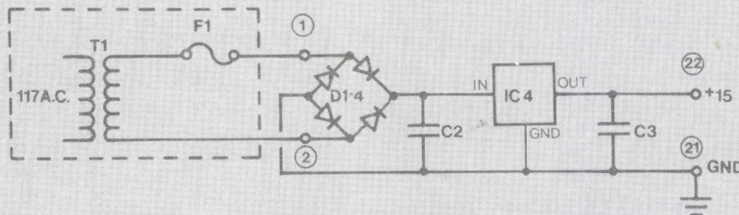

figure 1

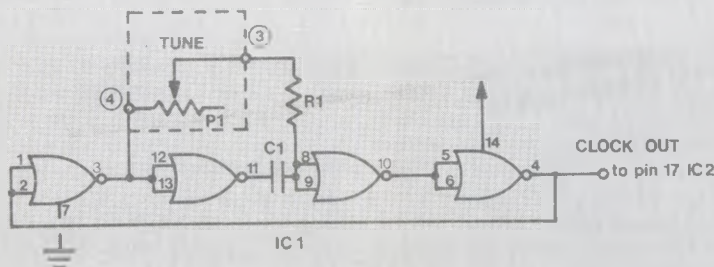

figure 2

Now on to figure 3. Pin 1 is power. Pin 2 delivers a trigger pulse at about +14V going to ground when a pedal is depressed. Q1 inverts this for a positive going pulse at the trigger output (Q2 performs a similar function for the gate output). Pins 3-15 are the pitch select inputs for the pedal switches. Each input here has a pedal switch contact which connects to ground, along with a 0.01 uF capacitor to debounce it. Pin 17 connects to the high frequency clock from figure 1. Pins 20-24 generate the squarewave outputs, ranging from 16' to 1'.

Figure 4 is the sound shaping circuit. The 16' and 8' outputs from IC2 hook into filters which are switched on and off by quad analog switch IC3. The signals are mixed at pins 2 and 3 before the final output, P3. The LEDs are optional, as is IC3 and the synthesizer interface (Q1, Q2, and direct outputs G-K).

**Construction.** Let's try to tie this all together. You'll need some pedals, but what about that set the keyboard player you know pulled off his Hammond organ? All you need is SPST contacts, with one contact going to the appropriate pedal output (pins 3-15) and the other contact going to a ground buss. Connecting these two contacts initiates the note.

I suggest building the circuit on a RadioShack breadboard #276-152 and a mating 22-44 pin edge connector. I use these for most of my projects, as they're easy to construct on and trouble-shoot with. Be sure to use sockets for all the ICs. They're all MOS devices and you certainly can't afford to blow up too many of the M-147B-1 chips.

Here's the suggested pinouts from the circuit board to the edge connector:

Pin #	
1	
2	External +15V supply
3	
4	Fine tune pot
5	
6	Perc. sustain switch
7	
8	C (low) pedal switch contact
9	C# pedal switch contact
10	D pedal switch contact
11	D# pedal switch contact
12	E pedal switch contact
13	F pedal switch contact

- 14 F# pedal switch contact
- 15 G pedal switch contact
- 16 G# pedal switch contact
- 17 A pedal switch contact
- 18 A# pedal switch contact
- 19 B pedal switch contact
- 20 C (high) pedal switch contact

- 21 Ground
- 22 System +15V

- a Trigger out
- b Gate out
- c 16' on-off
- d 8' on-off
- e
- f Decay pot
- g 16' direct out
- h 8' direct out
- i 4' direct out
- j 2' direct out
- k 1' direct out
- l Main output

#### Using the bass pedal system.

You need an amp and speaker capable of reproducing some low bass, since 16' low C is 32 Hz. The 16' and 8' switches select either or both. The percussion/sustain switch alternates between an automatic decay, or decay only after the pedal is released.

Interfacing with a synthesizer is straightforward: gate and trigger outs connect to an envelope generator, while you mix whatever squarewave footage you want to process into the external audio input.

Finally, take some time and care in laying out this circuit; it can be fairly tricky. Good luck and I hope you enjoy your bass pedals.

#### Parts list

**PARTS AVAILABILITY NOTE:** The M-147B-1 is available to Polyphony readers for \$10.95 plus \$1.50 for shipping. California residents add tax. Send check or money order to: Hawk Music Systems, 2011 W. 11th St., Upland, CA 91786.

#### Resistors and Potentiometers

R1, 3, 29,	
31	10k
R2, 18-23, 45	22k
R4, 24-28, 30,	
42, 46-48	1k
R5, 17, 33, 34	270k
R32	8.2k
R35	3.9k
R36, 40	6.8k

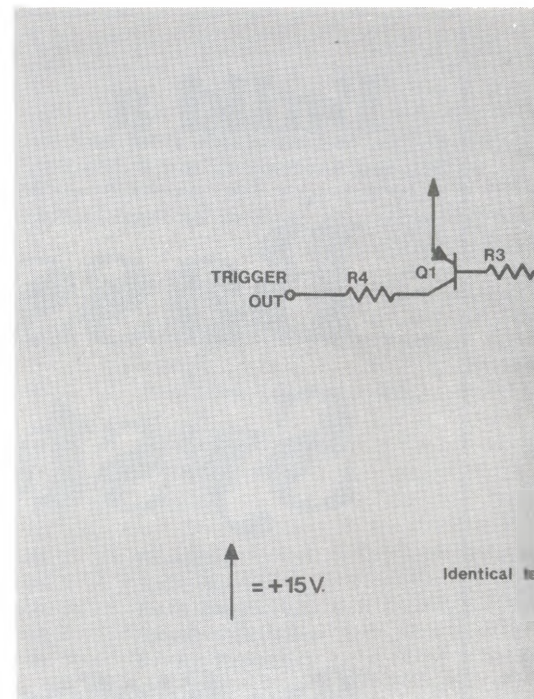

R37-41	68k
R38, 43	12k
R39	100k
R44, 45	220k

P1	5k (see text)
P2	75k (decay)
P3	50k (volume)

#### Capacitors

C1	47 pF
C2	1000 uF
C3	4.7 uF
C4, 19-25	0.1 uF
C5-17	0.01 uF
C18	10 uF

#### Semiconductors

D1-4	1N4002
D5, 6	1N914 or equiv.
D7, 8	LED
IC1	4001 quad gate
IC2	M-147B-1
IC3	4066 quad switch
IC4	7815 +15V reg.
Q1-3	2N3406, 2N5138 PNP
Q4, 5	2N5138 PNP
Q6, 7	2N5133 NPN

#### Miscellaneous Parts

S1	SPDT footswitch
S2, 3	SPST footswitch
Sx	Set of bass pedals
F1	1/4 A fuse
T1	R. Shack #273-1385
	12.6 VAC @ 300 mA

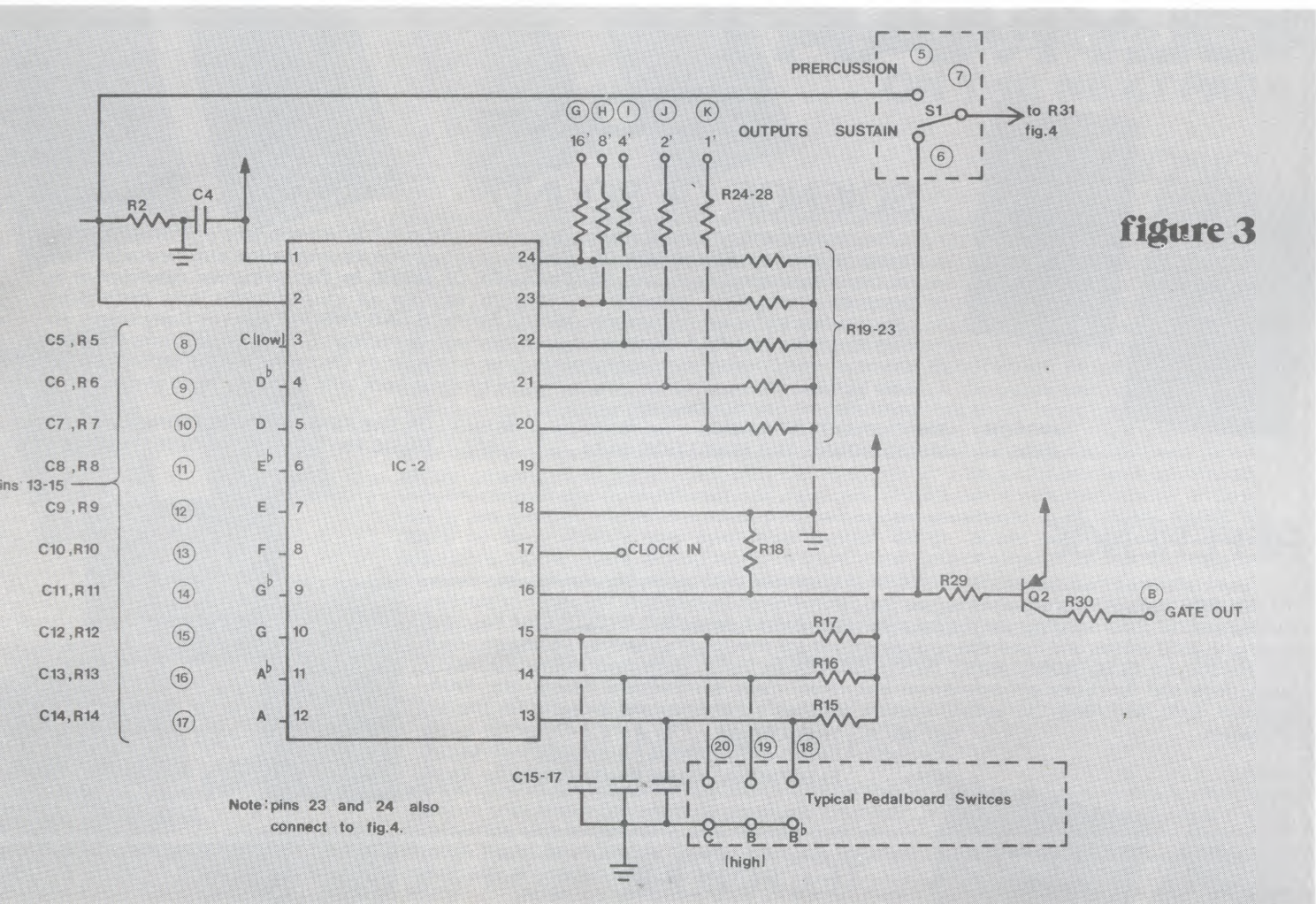

figure 3

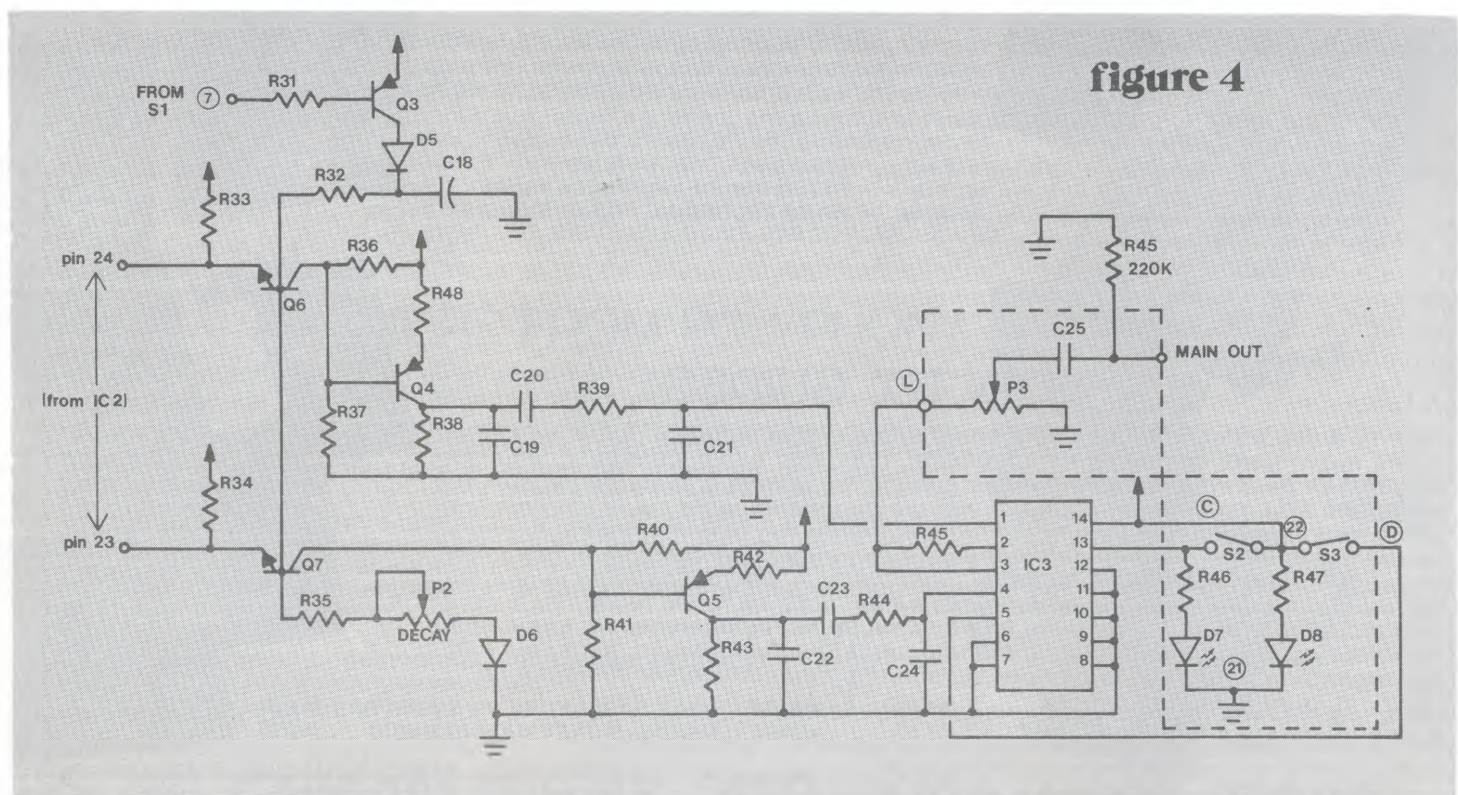

figure 4

# POLYMART

## BOOKS



### SCIENCE OF SOUND

The physical and psycho-acoustical background to music is an important part of musical synthesis. Helmholtz's **SENSATION OF TONE** is, a century after its publication, still the standard text for the physiological acoustics. **PSYCHOLOGY OF MUSIC** by Carl Seashore, developer of the Seashore Music Test, provides an in-depth analysis of musical style and performance characteristics of many instruments. **MUSIC, PHYSICS AND ENGINEERING** by Harry Olson, who worked on the first RCA synthesizer, is a thorough discussion of the physical properties and design of traditional musical instruments (plus a chapter on electronic music). **MUSIC, SOUND AND SENSATION** by Winkel is much like the Helmholtz work, with a bit less detail and more concentration on psycho-acoustics.

#PSYCH	PSYCHOLOGY OF MUSIC	\$6.00	#SENS	ON THE SENSATIONS OF TONE	\$8.95
#MSS	MUSIC, SOUND AND SENSATION	\$4.50	#MPE	MUSIC PHYSICS AND ENGINEERING	\$6.50

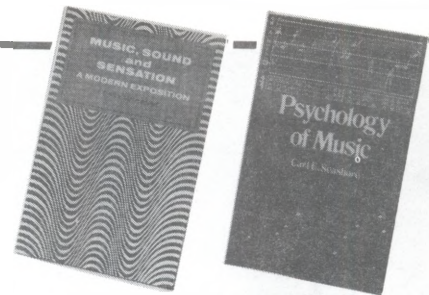

### REFERENCE

Often used reference materials to answer the many questions encountered in everyday synthesis. **THE SOURCE** Book of Patching and Programming from Polyphony has over 125 pages of patches in universal flow chart notation; the largest publication of its type. **AUDIO CYCLOPEDIA** has 1760 pages with 3650 entries and hundreds of drawings and schematics to answer any question about ratio. Hardbound. **ELECTRONIC MUSIC SYNTHESIZERS** by Delton Horn devotes the first half to descriptions and functions of commercial electronic music synthesizers (Moog, Arp, PAIA, Oberheim, EML, and RMI); the second section provides schematics and projects for the experimenter.

#SOURCE	THE SOURCE	\$4.00
#CYCLO	AUDIO CYCLOPEDIA (hardbound)	\$44.95
#EMS	ELECTRONIC MUSIC SYNTHESIZERS	\$6.95

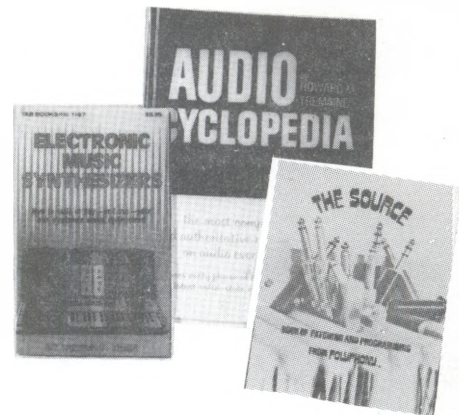

### TECHNIQUE

Synthesists must be well versed in a number of techniques and principles. "How To" and project oriented books are a great way to pick up these skills. **MULTITRACK PRIMER** by TEAC is a step-by-step guide to building, outfitting and operating your home studio. The Byte Book of **COMPUTER MUSIC** describes computer control of electro-mechanical instruments, Fourier analysis, circuits and loads of software. **HOME RECORDING FOR MUSICIANS** is Craig Anderton's original guide to outfitting and operating a budget studio for maximum results, includes mixer and other audio processing circuits and a sound sheet demo recording.

#TEAC	TEAC MULTITRACK PRIMER	\$4.95
#BYTE	BYTE BOOK OF COMPUTER MUSIC	\$10.00
#HRFM	HOME RECORDING FOR MUSICIANS	\$11.95

### "HOW TO" GUIDES

**HOW TO BUILD A SMALL BUDGET RECORDING STUDIO FROM SCRATCH** by F. Alton Everest covers twelve tested designs. **HOW TO DESIGN TEST AND BUILD COMPLETE SPEAKER SYSTEMS** BY David Weems is a do-it-yourself guide for the ultimate in sound quality. **HOW TO MAKE AND SELL YOUR OWN RECORD** — With the major lables having severe economic problems, many insiders feel that the future of the music industry may be in independent record production. Learn the ropes with Diane Sward Rapaport's indispensable handbook of how to get started. **MAKING MONEY MAKING MUSIC** by James Dearing — Everyong dreams of being at the top, but there's an enormous amount of "middle money" out there for the taking. This is not a book about how to become a Millionaire Rock Star, but the strategies revealed will give you the knowledge you need to keep afloat if you decide to pursue a recording contract. A fresh and practical approach to staying alive in the music business. From the publishers of Writer's Digest.

#BRS	BUDGET RECORDING STUIDO	\$9.95	#MASR	MAKE & SELL YOUR OWN RECORD	\$11.95
#CSS	COMPLETE SPEAKER SYSTEMS	\$7.95	#MMM	MAKING MONEY MAKING MUSIC	\$12.95



**ORDER FROM: POLYMART, P O BOX 20305, OKLAHOMA**

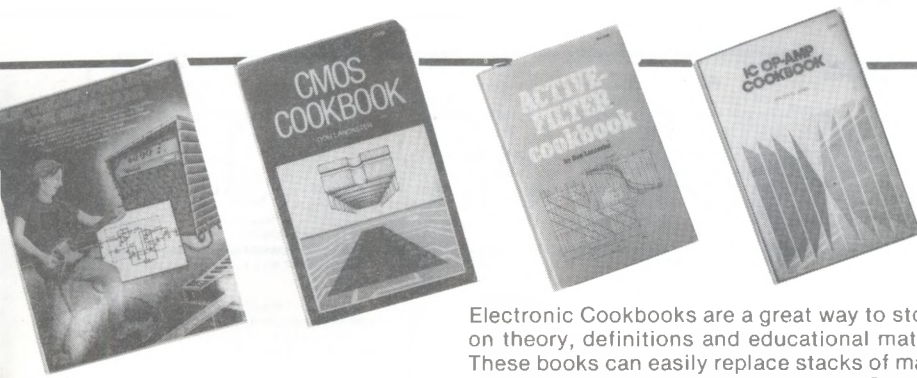

# USE THE ORDER FORM ON THE NEXT PAGE

## ELECTRONICS

Electronic Cookbooks are a great way to stock your library with materials that are not only heavy on theory, definitions and educational material but chock full of practical applications as well. These books can easily replace stacks of manufacturers data sheets and applications notes all in an easy to use reference. Walt Jung's **OP-AMP** and Don Lancaster's **ACTIVE FILTER** Cookbooks are self-explanatory — required reading for synthesists! **AUDIO OP AMP APPLICATIONS** is an edited version of the Op Amp Cookbook by Walter Jung, containing only audio applications. Lancaster's **CMOS** book is much more than a digital reference — phase lock loops, top octave generators, touch switches, and other things you need. **ELECTRONIC PROJECTS FOR MUSICIANS** by Craig Anderton is almost in a class by itself. It discusses electronic construction technique for the novice and provides 27 projects with printed circuit board patterns and a demo recording of the effects. Even if you're an old hand at musical electronics, you'll appreciate that all of these processors, from Tube sound Fuzz to Phase shifter are compatible and work together without creating noise, signal loss, bandwidth compression or any of the problems common to interconnecting effects from different manufacturers. There's even a complete chapter on how to modify and combine effects to produce your own custom pedalboard. **ELECTRONIC MUSIC CIRCUITS** by Barry Klein covers synthesizer system design, power supplies, control voltage generators, VCOs, Filters, analog multipliers and more. Lots of schematics and data sheets on the most popular music oriented ICs. An excellent technical reference.



#OACB	OP-AMP COOKBOOK	\$15.95	#EPFM	ELECTRONIC PROJECTS FOR MUSICIANS	\$14.95
#AFCB	ACTIVE FILTER COOKBOOK	\$14.95	#EMCR	ELECTRONIC MUSIC CIRCUITS	\$16.95
#AUOA	AUDIO OP-AMP APPLICATIONS	\$8.95	#CMCB	CMOS COOKBOOK	\$12.95

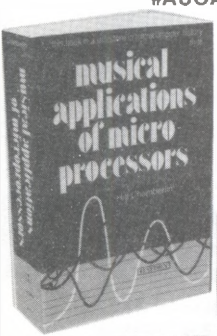

**NEW**

## EXCITING NEW BOOKS!

**MUSICAL APPLICATIONS OF MICRO-PROCESSORS** by Hal Chamberlain — If you only have space in your library for one book on music synthesis, this is the book. The easily read text is entertaining and enlightening and teaches both basics and advanced theory without plowing through pages of equations. Liberal examples illustrate theory and practice of both digital and analog signal generation and processing.  
**#MAM MUSICAL APPLICATIONS OF MICRO-PROCESSORS \$19.95**

**THE COMPLETE GUIDE TO SYNTHESIZERS** by Devarahi — An extraordinarily thorough treatment of the subject of analog synthesizers. Covers everything clearly, and the suggested experiments are excellent. Well organized and leaves nothing out.  
**#CGS THE COMPLETE GUIDE TO SYNTHESIZERS \$15.95**

**PRACTICAL GUIDE FOR CONCERT SOUND** by Bob Heil — Finally, a manual that explains in very simple language those many "magic terms" you've heard for years and never really understood. It's the first book written especially for musicians, roadies, and sound technicians who want to KNOW and UNDERSTAND what their sound system is all about.  
**#PGC PRACTICAL GUIDE FOR CONCERT SOUND \$10.00**

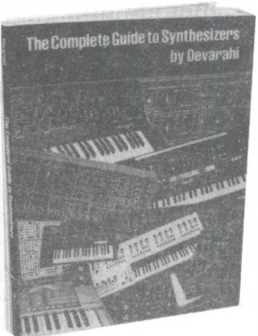
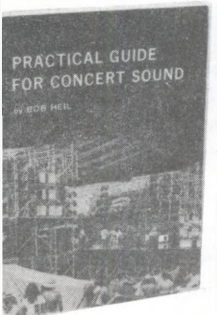

**NEW**

## & MORE FROM POLYPHONY

**4/8 TRACK STUDIO LOG BOOK** designed by Craig Anderton provides a place to keep all the important information on your tape library. Log in timing, type of tape used, record patches, make notes and use the expanded track sheet to list sequential changes in tape tracks relating to the settings of the index counter. Craig Anderton's **CONTEMPORARY KEYBOARD ARTICLES** is a collected reprint of all the articles from June 1977 through February 1981, covers tips, technique, theory, maintenance, and numerous construction projects. **DEVICE BACK ISSUES** — during the year that this newsletter was published, it featured almost 200 pages of technical information for the guitarist/musician. A wealth of articles on design, product reviews, and modification and construction projects. Sold in complete set, individual issues not available. Limited number available. **CRAIG ANDERTON MUSIC TAPE** — Delightful listening plus a booklet explaining how the effects were achieved.

#SLB	STUDIO LOG BOOK	\$4.95
#AA	CRAIG ANDERTON'S CONTEMPORARY KEYBOARD ARTICLES	\$5.95
#DEVICE	COMPLETE SET (12) DEVICE BACK ISSUES	\$18.00
#CAMT	CRAIG ANDERTON MUSIC TAPE	\$5.95



**CITY, OK 73156 (405) 842-5480**

# BACK ISSUES \$ 2.50 each ppd

## Find out what you've missed!

- #0204: 4/76: music notation - timing, external inputs for Gnome, Programmable Drums, Equally Tempered D/A, low cost AR project, digitally encoding keyboards, patches, Volume 1 & 2 index.
- #0301: 7/77: frequency divider project, random tone generator project, normalizing synthesizer controls, eliminating patch cords, computer control of analog modules, Chord Egg modification, adding pitch bending, patches.
- #0302: 11/77: The Sensuous Envelope Follower, digital gates, LED wall art, build a bionic sax, data to music peripheral project, Apple II as a music controller, using the NE566 as a VCO, patches.
- #0303: 2/78: computer controlled Gnome, using joysticks, build a bionic trumpet, ultra-VCO modifications, voltage control the Mu-Tron Bi-Phase, oral joystick, patches.
- #0304: April/May 78: Minimoog modifications, non-keyboard module use, phasing and flanging (theory and circuits), memory expansion for programmable drums, digitally addressed transposer project, polyphonic software (with software transient generators), patches, Volume 3 index.
- #0402: Sept/Oct 78: electronic music notation, notes on the recording of "Cords" by Larry Fast, sequencer software - part one, rhythmic control of analog sequencers, touch switch projects, modular vocoder techniques, PET as a music controller, patches.
- #0404: January/March 79: add-ons for vocal F and V converter, shorthand patch notation, more on note to frequency conversion, graphic monitor project, George Russell, super VCA circuit, echo software, Vol. 4 index.
- #0502: July/August 79: hex VCA/mixer project, electronic music schools and studios, modify the Oberheim Expander Module, profile of Ernest Garthwaite, budget microphones, digitizer projects and software, bar graph ICs.
- #0505: January/February 80: Joseph Byrd, Mort Garson, Larry Fast on 'Games', composing for 'live plus tape', using the CA3280, recording vocals, ADSR circuits.
- #0506: March/April 80: Computers in Music: real time audio processing hardware, Powell sequencer system, Max Mathews, advanced STG software, PortaStudio, phase modulation, Volume 5 index.
- #0601: May/June 80: Gary Numan, Microcomputers in Real Time Audio, Build a Digital Audio Delay Line, writing Documentation, Richard Hayman Composer/Performer Home Recording: Applying Harmonizing and Pitch Transposing Techniques by: Craig Anderton.
- #0602: July/August 80: Peter Gabriel, digital VCO project, dream modules, optimum level settings, dynamic phrasing, patches.
- #0603: Sept/Oct combined with Nov/Dec 80: alternate controllers, add voices to Casio M-10, voltage controlled quadrature oscillator project, cordless patch bay, recording rules, patches.

- #0604: January/February 81: Special Construction Edition; Build: Audio Circuit Breaker, Pulse Width Multiplier, Magnetic Harp, 50 Watt/Channel Stereo Power Amp, Quad Sequential Switch, DOD Mods, patches.
- #0605: March/April 81: Portable Music Issue, reviews of Remco's FX, E-H Mini-synthesizer, Casio's VL-Tone, plus mods for the M-10. GR-500, mini-amp, and the Korg X-911. Introducing; Practical Circuitry and On Location, new columns.
- #0606: May/June 81: Synthesizer: Hardware Mods and Software. Modular Synthesizer Effects, Environmental music. Keyboard assignment for the 8700, new columns; Details, Practical Circuitry, and On Location. Volume 6 index.
- #0701: July/August: Guitar Electronics: Modify; Fender Amp, MXR Phase 100, GR-500. Input/Output Structures, \$5 Analog Programmer, Sample and Hold technique, Modular Synthesizer Effects, new column: Applied Synthesis, Marketing Your Records.
- #0702: Sept./Oct.'81: Harald Bode Interview, Live Plus Tape - New Technique, Xenharmonics, Kraftwerk Live - Review, Psycho-Acoustic Experiments, Practical Circuitry - Super Controller, Applied synthesis - Brass, Construction Tips For Beginners.
- #0703: Nov./Dec.'81: Dave Rossum interview, Applied Synthesis: Strings, Details: Series-parallel/Sum-Difference, The Sound Gizmo and Pro-One Reviews, Practical Circuitry: VCO Deluxe.
- #0704: Jan./Feb.'82: Bob Moog interview, Chip Power - STK-050/070, Simple Square Wave Shaper, Tape Timer Ruler, Practical Circuitry: VCAs made simple, Details: Gozinda & Gozouta Revisited, Korg Trident & Casiotone 202 Reviews.
- #0705: Mar./Apr.'82: Electronic Music Math, Analog Delay Clock / Modulation; Frequency Domain Modifiers; Screen-Wave for the TRS-80; Touch Switches Revisited; Practical Circuitry: ADSR the Easy Way; Getting the most out of a Cheapo (Guitar).
- #0706: May/August '82: Anatomy of a Private record, Don Slepian Interview, Understanding Digital Synthesizers: A Digital Filter, Syn-Bow Review, Optical Audio, Profiles of SSM 2033 & 2044, The PAL Filter, Bill Rhodes Applied synthesis: Bells, Pipe Organ, Harpsichord, Electronic piano; The Realistic MG-1 Reviewed.
- #0801: Sept/Oct.'82: Ambience in Electronic Music, Tone Bypass for Fender Amps, 8 Track Reviews, Parametric EQ Tips, Solo/Cut Circuit for TASCAM Model 3, The SSM 2011, Tube Preamp, Snare + Drum Voice Circuit, Triple Pick-up Switcher, Simulated Stereo, When Quality Record Mfg. Counts, Independent Record Mfg. Convention report.
- #0802: February '83: AMS-100 Gate Output, Bus Distribution Modules for Modular Synthesizers, Dynamic Touch Controller, Expanding Envelopes, MXR Limiter Review, New Age Music, An Overview, Synsonics Drum Review, Interface, Practical Circuitry: A Patch Over Scheme for Small Synthesizers, Lab Notes: Shepard Functions.

## CASIO M-10 OWNERS.....

Did you realize that your pride and joy has unseen powers? That there are voices and effects that you can add for the cost of a switch and a piece of wire? This latest booklet from POLYPHONY gives you the info that you need to transform your mini-axe and gives details on adding a "stunt box", computer interfacing and much, much more.

No. CMOD 16 pages .....\$3.50

## SSM 2011 CHIPS

As a special service to readers interested in evaluating this exciting new chip, for a limited time POLYMART offers the SSM 2011 Microphone Preamp/Level Detector IC. No. 2011 .....\$5.75 each plus postage (\$1.00)

## RACK PANEL SPECIAL!

Easily machined 1/8 inch unfinished aluminum rack panels as low as \$3.95 each in quantities of 3 or more. (you may mix sizes for discount prices)

	Quantity	
	1	3 or more
single size - 1-3/4".....	\$5.25	\$3.95 each
double size - 3-1/2".....	\$9.25	\$7.95 each
triple size - 5-1/4".....	\$12.95	\$11.95 each

## ORDER FORM

We cannot invoice; payment must be enclosed with your order. there is a flat \$.50 handling fee per order plus postage costs. MasterCard and Visa are welcome. (\$10.00 minimum charge). Foreign orders **must** be paid by certified check or money order in U.S. \$ drawn on a U.S. bank (or by charge card). Phone orders welcomed for charge card orders.

### SHIP TO:

Name: \_\_\_\_\_  
 Address: \_\_\_\_\_  
 City \_\_\_\_\_ State \_\_\_\_\_ Zip \_\_\_\_\_



Card # \_\_\_\_\_  
 MasterCharge Bank # \_\_\_\_\_ Expiration Date \_\_\_\_\_  
 Signature \_\_\_\_\_

Quantity	Item	price ea.	amount
SUBSCRIPTION U.S. \$12/YR. FOREIGN \$14/YR.			

Shipping Charges  
 U.S.: add 10% of SubTotal or \$5.00 maximum  
 Foreign: 20% of SubTotal or \$10.00 maximum

sub total	
handling	.50
shipping	
total enclosed	

**MAIL TO: POLYMART, P O BOX 20305, OKLAHOMA CITY, OK 73156**

# CURRENT EVENTS

*'Tell Them You Saw It In Polyphony'*

**CMOS 6502.** Rockwell International (4311 Jamboree Road, Newport Beach, CA 92660) has announced the R65C02, a CMOS version of the 6502 microprocessor that accepts clock speeds up to 4 MHz, includes 12 new instructions, and draws about 5% as much current as its NMOS equivalent.

**Calling all musicians.** Making Money Making Music, by James Dearing, is a sympathetic, fact-filled, 320 page book which looks at how musicians can make a living by concentrating on good-paying, local jobs (orthodox and unorthodox) rather than the elusive pot of gold of national stardom. His words are to the point, and show the compassion and humor of somebody who's "been there". Delivers what the title promises. Published by Writer's Digest Books, 9933 Alliance Road, Cincinnati, OH 45242. Available from Polymart for \$12.95.

Another book, "Index to Alcohol, Drugs, and Intoxicants in Music", has been published by Polyphony author Dr. Andrew Gelt. 471 entries, 59 page typescript, statistical data, vinyl cover. \$15.50 ppd from Dr. Gelt at 10919 Fairbanks Rd. NE, Albuquerque, NM 87112.

**More monolithic filters.** National Semiconductor (2900 Semiconductor Dr., Santa Clara, CA 95051) has announced three inexpensive CMOS filters: the MF4, a CMOS fourth-order Butterworth low pass filter; the MF5, a second order universal (low pass, high pass, all pass, notch, bandpass) filter; and the MF6, a sixth order low pass filter.

Reticon (345 Potrero Ave., Sunnyvale, CA 94086) has announced the R5621, which contains two second order filters in one package; it creates a number of useful filters, including elliptical and biquad types (it may also serve as a sine wave oscillator). The R5622 contains four second order filters in a 20 pin package.

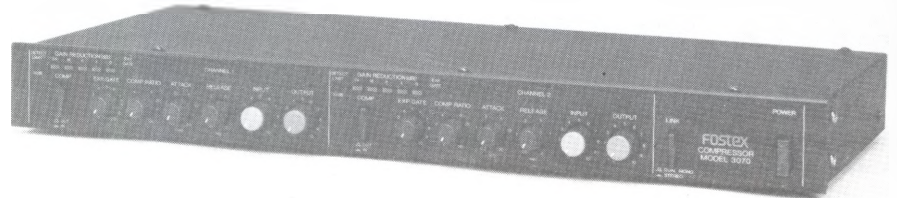

**New spring reverb, compressor/limiter, lower price.** Fostex (15431 Blackburn Ave., Norwalk, CA 90650) has announced the 3180 2 channel reverb (list \$400). It features built-in pre-delay and limiter, LED overload indicator, and paralleled front/back panel input/output jacks.

The 3070 gated compressor/limiter uses high frequency pulse-width modulation techniques and includes a noise gate function, LED gain reduction display, dual mono/stereo mode, attack/decay controls, and VCA detector jack. \$400 list.

The A-8 1/4" eight track recorder has been reduced in price to \$1995; a new model, the A-8LR, can record 8 channels simultaneously (the A-8 is limited to four simultaneous tracks) and lists for \$2500.

**Color Computer, meet music.** DANS (13 Cedar St. Rm 130, Martinsburg, WV 25401) has announced software on cassette for the Radio Shack Color Computer (16K memory minimum) which gives it single-voice synthesizer capabilities. Notes are played on the upper two rows of keys; attack, decay, sustain, and release are adjustable. The program supports pitch bending in both directions, as well as vibrato and a "pitch-bend-on-attack" feature for twang effects.

**New "Producer Series" products.** Yamaha has introduced the MS10 powered monitor speaker (20 Watts RMS, 6.75" X 6.5" X 11"). Suggested uses are for portable

cassette players, practice amps, monitors, etc. It includes bass, treble, and volume controls.



**NED meets GR.** The GR System interface (developed for and used in Roland's guitar synthesizers) has been accepted as the standard by the New England Digital Corporation. This means that NED will be using Roland GR series guitars to interface to their Synclavier Digital Synthesizer, thus opening up digital synthesis techniques to the guitarist.

In other Roland news, the Jupiter-6 (retailing for \$2,995) is a six-voice version of the Jupiter-8 (which recently has been reduced in price from \$6,495 to \$4,995). It includes the MIDI interface.

# CURRENT EVENTS



**Effect Switcher.** JL Cooper Electronics (2800 South Washington Blvd., Marina Del Rey, CA 90291) has introduced an Effect Switcher capable of switching 14 effects anywhere in the signal path. 64 patches may be stored in memory, along with eight control voltages and three switch closures, and dumped to tape via cassette interface. \$2000; customized units available.

**SSM evaluation/voice board.** Solid State Micro Technology for Music (2076-B Walsh Avenue, Santa Clara, CA 95050) has introduced the 5010 Synthesizer Board. It includes the board, two SSM2033 VCOs, SSM2022 dual VCAs, SSM2044 lowpass filter, SSM2022 state variable filter, two SSM2056 envelope generators, and two hard-to-find 1% resistors. There are also provisions for on-board LFO, noise source, and on-board regulation. All controls, inputs, and outputs pin out separately to a standard 100 pin edge connection. More than one board can be used for polyphonic applications. Contact the factory for pricing and availability.

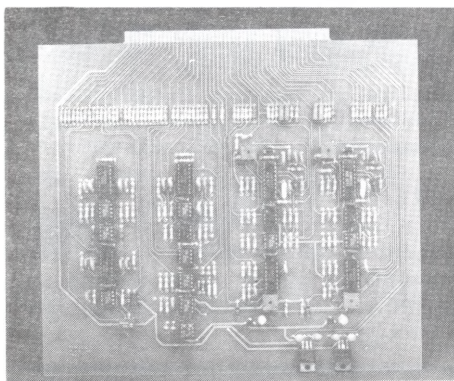

**New Lead Synth.** The Syrinx lead synth from Synton (Box 83, 3620 AB Breukelen, Holland) offers several unique features. The filter section includes not only the usual 24 dB/octave LPF but also two resonant peak filters. A special "Touch 'N Bend" control makes for natural modulation control, and there are many modulation options. Other features include a ring modulator, noise generator, independent VCF and VCA envelope generators, two VCOs, and a 3.5 octave keyboard.

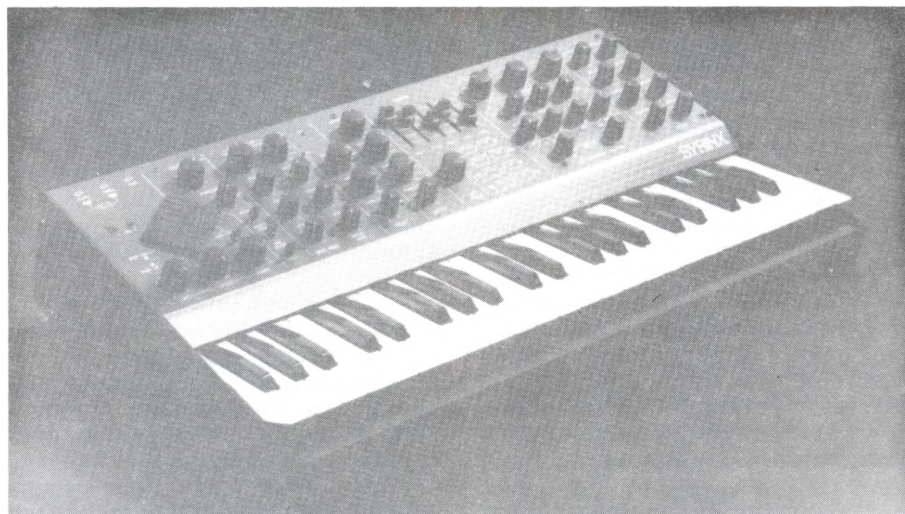

**Hear, hear!** I never run a drill press, chain saw, or the like without ear protection -- and I think it really has helped preserve my hearing. Some of the best ear protectors I've run across are made by EAR Corporation, 7911 Zionsville Road, Indianapolis, IN 46268 (telephone 317-293-1111). They can tell you the address of your local distributor.

**IEMA update.** Don Slepian submitted the following: "The International Electronic Music Association held its 3rd annual convention on 11/13/82 at the Appel Farm Arts and Music Center in Elmer, NJ. In a beautiful, secluded theatre there were 6 hours of live electronic music featuring performances by the Atomic Thinkers, the Nightcrawlers, Doug Walker and the NYC Electronic Music Collective, Tom Masapallo, and Lauri Paisley. Off-stage records and tapes were exchanged and sold, technical secrets revealed, software traded, music debated, and many friendships renewed.

"Membership in the IEMA is open to anyone who plays or enjoys electronic music. The \$12 annual fee brings the irregularly published journal, SYNE, and connects you to other synthesists in your area and around the world. Send name, address, and membership fee to Jim Finch, PO Box 456, Salamanca, NY 14779."

**Software.** Notable Software (PO Box 1556, Philadelphia, PA 19105) has released "Musical Match-Up", an instructional music game for the Apple II. No additional hardware is required. Requires DOS 3.3, Applesoft BASIC, 48K RAM, one disk drive. \$25 (educational discounts available).

**New linear IC process.** Texas Instruments has developed LinCMOS, which combines the low voltage, low power, and high input impedance of CMOS circuits with low offset and wide voltage swings. The first two op amps of this series are the TLC251 and TLC271, which run off 1 to 6V supplies (batteries, anyone?), have a slew rate of 4.5V per microsecond, and



a noise figure of around 30 nV/root Hz. While this spec is not exactly low noise, the company anticipates lower noise figures as the process is perfected.

The following press releases were all received April 1st:

**New Recorders.** TAEC (3377 Oersted Lane, Anaheim, CA) has introduced the 712, the first 12 track recorder which uses 3/4" tape. "We saw a gap between 8 track 1/2" and 16 track 1", so we filled it" said Gimball Sprocket, Director of Engineering. List price is unavailable at press time, as is 3/4" audio tape.

Fosstech (213 Capstan Drive, Otari, CA) has announced the Model C-9 nine track cassette recorder. Physically configured like a four track, Fosstech squeezes out nine tracks by making one track carry sync information, while the remaining tracks have sounds multiplexed on to them (3 sounds per track) "at a real, real fast rate". On playback, the sync track de-multiplexes the sounds. The recorder lists for \$50; however, the optional anti-aliasing filter network costs \$2,750.

**"Musicians for Electronic Projects".** Craig Anderton's first book written for electronic projects demystifies how musicians work. Effects learn how to beg for alkaline batteries, what to do if they're stuck with an owner who uses acid core solder, and why they are sometimes kicked or hurled across the room. Includes illustrations and psychological profiles of 27 different types of musicians. \$10.95 from Android Press (40 Widget Street, Cincinnati, OH).

**New delay line.** The ME-2 delay line from ME-2 Electronics (1024 Photocopy Road, Similarville, MO) has a maximum delay of 1024 milliseconds, an output balance control, a triangle wave modulation section, feedback control, and some jacks on the back. It is priced competitively with the other 2,345 delay lines sharing similar, if not identical, characteristics.

**New IC Unveiled.** According to Douglas Electromusic Specialties, Synthesizersource had to take second seat to some new chips they were working on. Little did we know the sophistication of the latest chip from DES; we can certainly understand why it would push any other project into the

background.

This project took three years, including an intensive collaboration between Douglas and Don Row, president of The Solid State Semiconductor Company with the Longest Title on the Entire Planet or Even the Entire Galaxy (SSCLTEPEEG). "Neither of us had sufficient resources to develop this chip independently", said Don. "But the results are so encouraging we will be doing more together in the future".

The multi-function chip includes:

- Programmable black noise generator, which provides a reliable source of non-signals.
- Clock generator. This is for when you want to know how much time is left until the gig is over.
- Micro processor. Shreds, cuts, slices, and dices micros.
- Uncommitted transistor array. We asked if they were NPN or PNP, but they wouldn't commit themselves.
- Delay line. Unfortunately, the introduction of this feature has been delayed, but both Curt and Don claim the Rev 2 versions will include this important feature.
- Uncontrollable radio fre-

quency generator. "Actually", said Curt, "this started out as a VCA. But we couldn't figure out how to compensate it, so what the hey".

The DES/SSCLTEPEEG 3203 is packaged in a 48 pin dip with external cooling fins and a small on-board nuclear reactor. Contact either factory for details on pricing and availability.

**Homosapiens Electronics introduces Programmable Musician.** HE,, manufacturers of numerous programmable instruments, has introduced the TR-HS android. "We noticed that real musicians get pretty bored just programming stuff, pushing a button, and letting the machines play. After seeing an electropop concert where the musicians fell asleep on stage while programmable instruments and tape tracks played on, we decided there must be a solution. The TR-HS is that solution", said Arthur Deetoo, director of Android Development. The android is also programmed to call DJs incessantly until a particular record gets played, has road-worthy bionic arms, speaks five languages including Hip and Jive, and has a limited warranty of three score and ten years. . . .

## BY PROFESSIONAL DEMAND

DDC OFFERS FREE ADVICE, PERSONAL SERVICE AND ONE-DAY SHIPPING OF THE FINEST MUSIC AND SOUND EQUIPMENT AVAILABLE ANYWHERE:

**CROWN Traynor**  
**KORG polyfusion**  
**KELSEY**  
**TEAC** *Studio TUNER*  
**MXR**  
**DiMarzio**  
**REMO**  
**YAMAHA**  
**whirlwind**  
**prophet**  
**ARP**  
**intersound**  
**ASHLY**

PLEASE CALL OR WRITE FOR PRICES & ORDERING INFORMATION - YOU'LL BE GLAD YOU DID!

**DDC** DICKSTEIN DISTRIBUTING COMPANY  
 1120 QUINCY PPY-SCRANTON, PA 18510  
 PHONE ORDERS WELCOME (717) 344 7469

# Practical Circuitry

## My Favorite Transistor Circuits

By: Thomas Henry

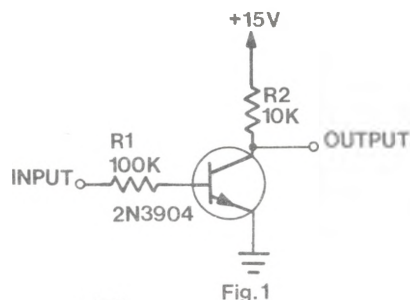

Fig. 1

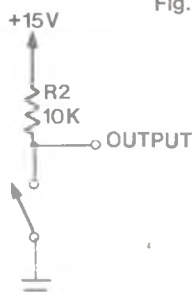

Fig. 2

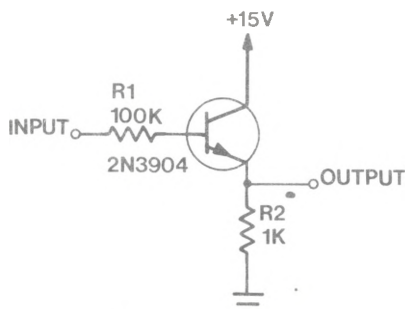

Fig. 3

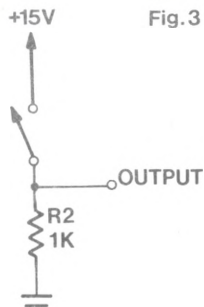

Fig. 4

It used to be that there were lots of oldtimers who could do the most marvelous things with vacuum tubes, but were totally out to sea when it came to transistors. This was simply a case of not keeping up with the advances in technology. But how about the reverse? Lots of people today seem to be able to design all sorts of neat things with solid state parts, but are lost when it comes to vacuum tubes. And finally, let's carry this to the extreme. What about the person who grew up with integrated circuits but can't design with either tubes or transistors? I'm that way! I learned electronics by building things with ICs and somehow seemed to miss all of the basics of semiconductor theory.

I suspect that there are lots of people who are in the same boat, especially among the younger Polyphony readers. A couple of years ago I decided to do something about this gap in my knowledge, so I bought a number of self-study books on the subject. At the end of the article I mention some of these books if you want to do likewise. But for right now let's look at four of my favorite transistor circuits that I have found along the way.

I should probably mention that in your own design work, most of the time you will want to use integrated circuits. They are usually very easy to use, make circuit board design simple, and will save you money. However, there are times when a transistor circuit will fill the bill more closely. Cases of this might be where you have only a single polarity supply (most linear ICs require a bipolar supply), need a heftier drive current than the IC can supply, or need to use some unusual characteristic of the transistor (perhaps for exponential or logarithmic conversion). With this in mind, let's look at four circuits where transistors are ideally suited.

Figure 1 shows about the simplest circuit you can design with a transistor: an inverting switch. It's hard to beat this for simplicity and versatility. Figure 2 shows that when the switch is open the output is at +15V, and no current flow through the switch contacts. However, close the switch and current flows

through the switch to ground. The output is thus at ground as well.

Looking back at figure 1, with no voltage at the input of R1 the transistor is off and no current flows. However, apply a voltage to R1 and current will flow through the base-emitter junction. By transistor action this will cause current to flow from the power supply through the collector straight through to the emitter and ground. The output is pulled to ground. Thus you can see that the switch is inverting.

You may wonder how such a simple circuit can be used. Well, one of the most important uses is level conversion. Suppose the input voltage is TTL level (0 to +5V) and you want to interface to another circuit using a +15V power supply. This circuit will do the trick, since for a transistor with a fairly high DC current gain (say of 100 or so), the +5V signal will be enough to turn the switch on. Hence, a +5V swing can trigger a +15V swing.

Another typical use is as a simple inverter. Suppose in your design you've used up all of the logic gates you had available, but you need one more inverter. You don't want to open up a new hex inverter package and waste the five unused units. This is a perfect time to use a transistor! And by the way, you can use just about any NPN transistor. I like to keep a big stock of 2N3904s on hand for this sort of application.

Figure 3 shows a non-inverting switch and figure 4 shows its mechanical equivalent. Consider figure 4 first. When the switch is open, no current flows through the switch and therefore the output is at ground. However, close the switch and current flows through the contacts. The output then swings to full supply.

By analogy, in figure 3 if no voltage is applied to R1 then the transistor is not conducting and the output is at ground. However, apply a voltage to R1 and current flowing through the base circuit will cause collector current to flow. A voltage drop will be developed across R2 and this is the output. As you can see, this is a non-inverting switch. A positive voltage on the input causes a voltage to appear at the output.

What's the use of such a circuit? Once again, level conversion comes to mind. But per-

haps more importantly is the fact that the circuit is really a buffer. The input impedance of the circuit, as shown, is about 100k so that this shouldn't load down the driving circuit appreciably. However, the output impedance is about 1k which can drive another, say, 100k source, with only 1% loading. So you can see that the output drive current is quite good. And this is the purpose of a buffer!

Figure 5 shows how we can take two of the inverting switches described above and cross-connect them to form an R-S flip-flop or latch. Can you see how Q1, R1, and R2 form one of the switches we talked about above? And likewise, Q2, R3, and R4 form another switch. The output of Q1 couples to the input of Q2 and the output of Q2 couples to the input of Q1. (Symmetry like this always gives me goosebumps!) Let's analyze the operation.

Suppose that output Q is low. This implies that transistor Q1 is off and therefore Q bar ( $\bar{Q}$ ) is high. Q bar is in turn coupled to Q2, turning it on. Therefore Q is low, confirming our original assumption. Now apply a brief logic one to the set input. This turns transistor Q1 on and pulls Q bar to ground. This in turn switches Q2 off and causes the Q output to go high. Hence the outputs have switched states. Note also that they will remain in this condition until a pulse is applied to the reset input. You can prove this to yourself by going through an analysis similar to the one given above for the set input.

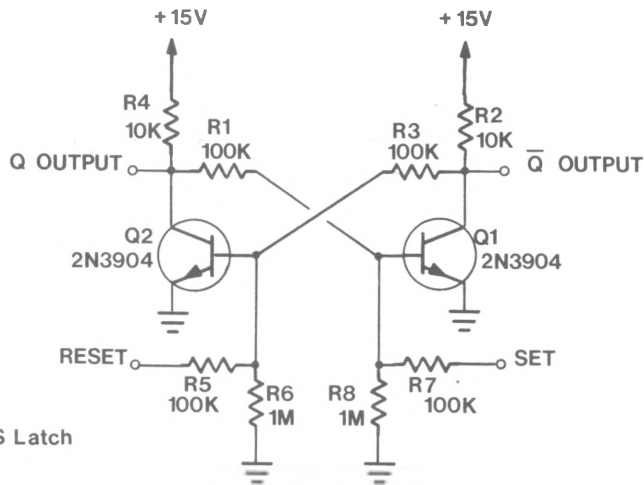
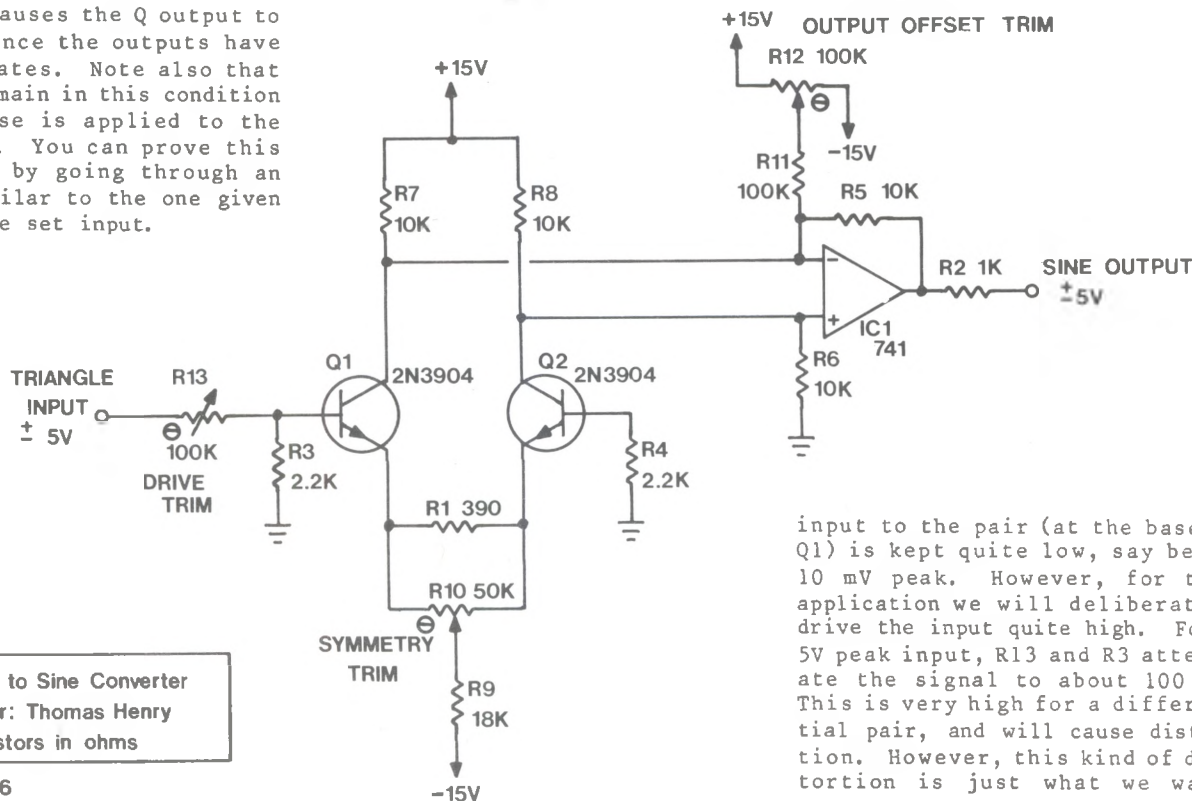

Fig.5 : R-S Latch

Figure 5 also shows the truth table for this circuit and you can see that this is the standard table for an R-S flip-flop. Most of the time you will want to use standard cross-coupled NOR gates for this circuit. But as mentioned above, occasionally you just don't want to crack open a new set of gates to only use a couple of them. Or perhaps the power supply is +24V. CMOS or TTL won't work here, but it's easy to find transistors that will work at this supply voltage. Conclusion: sometimes it pays to think discrete!

Let's leave the digital world and move on to the analog. Figure 6 shows one of my all time favorite transistor circuits: the triangle-to-sine converter. Readers of *Practical Circuitry* will remember this from the VCO Deluxe circuit presented some months back. I'm going to get technical for a moment so you can skip ahead to the next paragraph if you want; but if you've had a smattering of calculus, the theory of operation is quite simple. Q1 and Q2 form an approximate linear operation the



Triangle to Sine Converter  
Designer: Thomas Henry  
All resistors in ohms

Fig.6

input to the pair (at the base of Q1) is kept quite low, say below 10 mV peak. However, for this application we will deliberately drive the input quite high. For a 5V peak input, R13 and R3 attenuate the signal to about 100 mV. This is very high for a differential pair, and will cause distortion. However, this kind of distortion is just what we want!

## Practical Circuitry.....

Consider the circuit to be a transformation device. For a triangle wave input (over a certain range) it can be demonstrated that the output will be a modified hyperbolic tangent (abbreviated tanh). You study these sorts of functions in the calculus, but what's important to us here is that the hyperbolic tangent is a very close approximation to our ordinary sine wave (over specific ranges). This is all more technical than I want to get here, but if you want to see the full mathematical derivation of this, refer to the excellent article by Bernie Hutchins ("Mathematical Analysis of Differential Amplifier: Triangle-to-Sine Converters", Electronotes, volume 9, number 82, October, 1977, pp. 5-17).

If you skipped the last paragraph let me summarize what was said there in one sentence: the input to the device is a triangle wave and the output is a curve which resembles the ordinary sine wave very closely. Let's look at some of the circuit details.

The input should be a triangle wave with a 10V p-p amplitude.

R13 adjusts the drive voltage. R10 soaks up some of the inaccuracies caused by mismatching of the transistors. The output is a differential type and so must be converted back to a single-ended operation for standard audio work. The differential output is taken off of the two collectors and is sent to op amp IC1. The op amp converts the signal to a single-ended output with an amplitude of 10V p-p. R12 adjusts the offset so that the signal is symmetric with respect to ground.

You can trim this circuit up quite easily with an oscilloscope, but don't neglect your ears! The human ear is an excellent distortion measuring instrument, so be sure to listen to the signal while you tweak the circuit, even if you are using an oscilloscope. First adjust R13 while watching the waveform for smooth transitions at the peaks. Next trim R10 for basic symmetry. You want the positive excursions to look essentially like the negative excursions. Finally, tweak up R12 for zero center. That's all there is to it!

Writing this article was a lot of fun for me, and I hope you enjoyed this trip into the realm

of transistors too. More importantly, if you're like me and feel uneasy working with them, I hope this will inspire you to learn more. When I decided to correct my "deficient" background in transistors I dug up two books and conducted a self-study course of my own. These are Electronic Circuits by D. Casasent (New York: Quantum Publishers, 1973) and Electronics: A Self-Teaching Guide by H. Kybett (New York: John Wiley and Sons, 1979). I have never regretted looking into these books; they're both recommended, but Kybett is especially good, since it is written for transistor tyros who know a little bit about electronics. And it's self-paced as well. The other book is an excellent "one-stop" reference for anything transistor but is more technical. Do yourself a favor, read a good book this month!

---

**NEXT ISSUE:**  
**A one chip ADSR**  
**Poly-61 review**  
**& more.....**

## Musitech<sup>TM</sup> — two special offers

### Memorymoog<sup>®</sup>

Until June 15th, Moog<sup>®</sup> is offering a \$100 rebate with the purchase of the Memorymoog. Musitech has set special pricing for this offer. Call for our best price.<sup>1</sup>

### Soundchaser II<sup>®</sup> with Syscom<sup>®</sup> computer system

A special package: the Passport Designs Soundchaser II<sup>®</sup> with Turbo Traks<sup>®</sup> 16 Track software and Demo Disk included; the Syscom Apple<sup>®</sup> — compatible computer with Rana<sup>®</sup> Drive and interface card, NEC 1260 green phosphor monitor, a box of Elephant<sup>®</sup> diskettes, and a diskette storage file. This system is complete and ready to configure, at the very low price of \$2550.00,<sup>2</sup> shipping included. (This system is shipped UPS.)

Also in stock — vintage Moog Keyboards: Prodigy, Multimoog, Polymoog, and several of the last 25 Minimoogs produced (Special Edition). All factory-new with full warranties. Write or call for current stocklist/prices.

Musitech<sup>TM</sup> is a fully-authorized Moog Dealer and a factory-authorized Moog Service Center.

<sup>1</sup> The Memorymoog is shipped via Motor Freight, shipping charges collect.

<sup>2</sup> TN residents add 6.025% Sales Tax.

## Musitech<sup>TM</sup>

1631-A East 25th Street / P.O. Box 3717 / Chattanooga, TN 37404 / (615) 624-5600

# Dr. Rhythm

The Boss DR-55 is a versatile little drum box which resembles the PAIA Programmable Drum. However, one thing I didn't like is that the "rim shot" sound resembles a clave more than anything else. This may be fine for all the Bossa Nova fans in the audience, but chances are if you like to rock out a bit more some other sound would be more useful. This mod alters the clave to more of a tom sound.

Begin by removing the batteries (note that you'll lose any patches you've stored unless you can complete this modification in less than a few minutes, which is doubtful). Next, remove the four Phillips head screws located on the front panel, and pull off all five knobs. Then, unscrew the four Phillips head screws located on the front and rear lips of the case. Remove the front panel to expose the circuitry; note that the circuit board will fold back easily to allow access to the foil side of the board.

Locate the parts in the immediate vicinity of the Accent control on the component side of the board, as shown in figure 1. This is where the action is going to occur.

The capacitors labelled "1" and "2" in the diagram are 0.0015 uF units. Replace them with 0.01 uF mylar capacitors. Capacitor "3" is a 0.0022 uF unit and should also be replaced with a 0.01 uF mylar cap. Capacitor "4" (0.0022 uF) should be changed to 0.05 uF; finally, the capacitor marked "X" (a 0.0027 uF unit) should be replaced with a wire jumper (or, solder a short on the foil side of the board in parallel with this capacitor).

Resistor "6" sets the overall level of the tom sound. 330k seems just about right, but feel free to experiment. Resistor "5" sets the resonance; I added a 1.8k resistor in parallel with "6" to increase the resonance somewhat.

After you double-check your work, re-assemble the DR-55 in the reverse order of which you disassembled it. Snap the batteries in place, patch to your amp, turn it on, and you're ready to go.

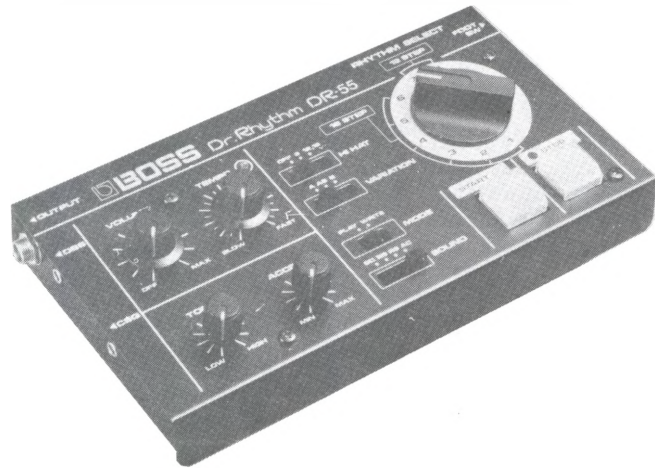

## Modification

By: Craig Anderton

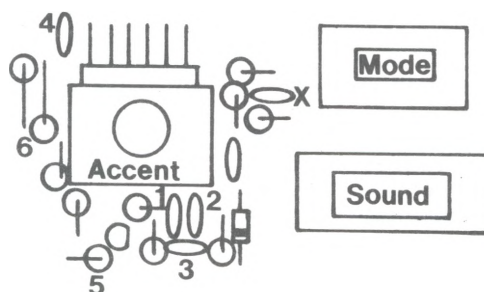

figure 1

# SOURCES IN

By: David B. Doty

The study of acoustics and psychoacoustics is a pursuit which I strongly recommend to anyone involved in electronic music. My own experiences in this area, while somewhat atypical, illustrate the value that knowledge of the physics of sound can have for an electronic musician. For a number of years prior to becoming involved with synthesizers, my musical activities included, in addition to composing and performing, the design, construction, and modification of acoustic instruments for use in alternative tuning systems. In pursuit of these activities, I found it necessary to devote considerable time and energy to studying the production, transmission, and perception of sound. As a result, when I turned my attention to synthesizers, I readily understood the functions of the various modules and had little difficulty in constructing effective patches. The vocabularies of acoustics and electronic music are essentially the same. Since I was already accustomed to thinking of sound in terms of frequency, amplitude, envelope, and waveform, using a synthesizer to control these musical parameters presented little difficulty.

I thought of writing about one or more aspects of acoustics for Polyphony, but it soon became evident that a thorough examination of even one topic in this field would require more space than this magazine could provide, and that I would, at best, be duplicating information which was already available elsewhere. As a result, I decided that the best approach would be to share with you some of the sources that I have found most valuable in my studies of acoustics and psychoacoustics. If you are new to synthesis, reading some of this material can help to ease your way through a maze of unfamiliar ideas. Even if you have had extensive experience in electronic music, you may find that it sheds new light on familiar phenomena.

Fundamentals of Musical Acoustics Arthur H. Benade  
New York: Oxford University Press, 1976.

Benade, an Indian-born physicist and flute player, provides what I regard as the best and most comprehensive study of musical acoustics currently available to the layman. This book progresses in a logical fashion from the simple to the complex, giving careful attention to details all along the way. Equations appear only when necessary, and an elementary knowledge of algebra should suffice for the understanding of everything presented here. The material examined includes room acoustics, the human voice, and all of the major families of acoustic instruments. Each chapter concludes with a number of experiments that may be conducted with simple equipment, many of which can be quite revealing.

Horns, Strings, and Harmony A. H. Benade  
New York: Anchor Books, 1960.

This book gets my recommendation as the best and most easily understood introduction to the science of music. The subject matter covered includes the basic behavior of vibrating systems, the nature of the human ear and its effect on the perception of music, and a simplified exposition of the law governing string and wind instruments. The style is conversational and non-technical, and no math is involved.

On the Sensation of Tone Herman Helmholtz  
(English translation) New York: Dover, 1954.\*

Helmholtz, in addition to his work in optics and physiology, played a major role in the creation of the science of musical acoustics. He is especially known for his work on combination tones and his attempts to establish a scientific basis for consonance and dissonance. In addition to his conclusions in these areas, this book contains information on the physiology of the ear, vowel sounds, and tones generated by pipes and strings.

The appendices in the English translation, by Helmholtz's British contemporary, Alexander J. Ellis, run to nearly 200 pages, containing extensive information on tuning and temperament and on the experimental keyboards of the 19th century. Taken as a whole, this book is like a great dusty attic. It contains many valuable treasures, hidden among equally many historical curiosities; a patient and discerning investigation is required to distinguish between them.

# ACOUSTICS

## re-view

Music, Physics, and Engineering Harry F. Olson  
New York: Dover, 1967.\*

This is a dense and presumably comprehensive work, touching on every aspect of sound generation and reproduction. Full of charts, tables, and equations, it is more valuable as a reference work than for cover to cover reading; just the thing if one needs to know, for instance, the relative frequencies of the modes of vibration of a clamped circular plate. The chapters on electronic music and recording are quite dated, with a considerable section being devoted to the RCA synthesizer.

Genesis of a Music Harry Partch  
New York: Da Capo, 1974.

Although this is not, strictly speaking, an acoustics text, I include it here for several reasons. First, it does include detailed information on the history of tuning systems and on the age-old debate as to the nature of consonance, from the ancient Greeks and Chinese to the mid-twentieth century. Beyond this, Genesis of a Music is the musical autobiography of a highly individualistic American composer, musician, and instrument builder whose work should be familiar to every D. I. Y. musician. This book has been a major influence on my musical life.

Introduction to the Physics and Psychophysics of Music Juan G. Roederer  
New York: Springer Verlag, 1975.

This book, unlike the others cited above, concentrates primarily on psychoacoustics. That is, it is concerned with the way sound is processed by the ear and the brain, as opposed to the physical phenomena that are its origin. This is a very detailed little book, dealing extensively with the physiology of the ear and the central nervous system and their roles in the perception of music. Topics include discrimination of pitch and loudness, perception of simple and complex tones, and the relative importance of spatial and temporal cues in current theories of consonance.

Those books marked with an asterisk (\*) are available through Polymart, but you may have some difficulty in finding the other books mentioned above. Do not despair; large public libraries and college music and physics libraries are good sources to investigate. If your local libraries don't have what you need, they can probably obtain it for you. Ask your reference librarian about the possibility of an inter-library loan

continued from page 11 .....

technical proficiency often seems to get in the way of the joy of music, but somehow this group managed both.

Cluster Sowiesoso (Sky 005; 1976). My continuing favorite among their series of lazy summer afternoon music.

Jack Nitzsche "Performance" Soundtrack (Warner Bros. 2554; 1970). Oh I know, it's spotty -- in places quite bad. But I love the movie and for 1970 the synthesis is killer.

Peter Baumann Trans-Harmonic Nights (Virgin 2124; 1979). Everything about this album gets classier every year. It cuts a clean profile -- sonically, musically, graphically, artistically.

Vangelis China (Polydor; 1979). I still like his, oriental impressions better than his sound track work. Good sonics too.

Syrinx Long Lost Relatives (True North 5; 1971). Canada's claim to electronic fame. The sound was theirs alone, the tunes memorable and the audience...silent.

Steve Tibbetts Yr (Frammis 1522-25; 1979). Everyone who is contemplating releasing their own record should get this one first -- if only to see how it's done.

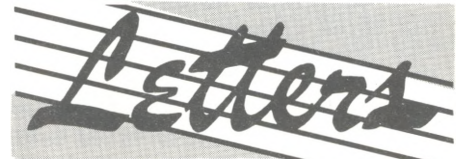

continued from page 11 .....

### SUBSTITUTION PROBLEMS

I recently built your keyboard preamp (see page 8 of "Craig Anderton's Keyboard Articles" -- ed.) and used an LM324 instead of the 4136. Even at low amplification, the output signal is heavily distorted, and the LED does not flash with this clipping. I am also interested in using this preamp to drive headphones. What modifications should I make?

Terrance Stewart  
Houston, TX

.....continued on page 38

# Meet SID

## 6581 Sound Interface Device

By: James Lisowski

Meet the new kid on the block, SID. SID (also known as the Commodore MOS Technology 6581 Sound Interface Device) is an amazingly powerful, microprocessor-compatible single chip sound generator/processor. While designed to be interfaced with minimum additional hardware to MOS Technology's 6500 line of microprocessors (such as the 6502 found in Apple, Atari, etc. computers), the SID should also be easy to connect to any other 8 bit microprocessor. The simplest way to meet SID would be to obtain the Commodore 64 computer, which uses SID as its audio effects center. Whatever your interest -- good computer sound effects or a dedicated audio synthesizer -- SID has a lot to offer.

**Oscillator capabilities.** SID has three independently controllable Oscillators (also called Voices). Since SID is a digitally controlled device, the frequency ranges of the oscillators are determined by the microprocessor's clock speed and the value of the Oscillator Frequency Control Registers. For each Voice, SID has two 8 bit wide Frequency Registers, HI and LO, each of which may hold a decimal number in the range of zero to 255. The HI and LO Registers respectively act as coarse and fine frequency controls, with 256 steps of the LO register being equal to 1 step of the HI register. With their combined values, these registers provide a 16 bit digital oscillator frequency control range. At the suggested 1 MHz clock speed, this oscillator range is zero to 4 KHz, or 8 octaves of the normal equal-

ly-tempered music scale. With proper use of the LO Frequency Register, most any micro-tonal value in this range may also be obtained. (The frequency resolution is limited by the amount of frequency change per single bit change in the control value. However, by changing the clock rate AND the register value, any frequency in this 4 KHz range could be created. Even if the clock is not altered, though, the 16 bit dynamic range allows frequency sweeps or portamento without discernible steps.) That's not bad latitude, even if these three voices were just the ordinary square wave you might expect from a digital circuit; but they're not just square waves!

Each SID voice may be one of four different waveforms, as selected by the bits placed in the Control Register. Triangle, sawtooth, pulse (or squarewave), and noise waveforms are available. If you choose more than one waveform, the result will be the logical AND of the selected waveform, creating a waveform of even greater complexity. As discussed previously, the frequency of each waveform may be controlled via the Frequency Registers, with higher values giving higher pitches. The noise waveform is a random signal. Changing the "frequency range" of the noise waveform alters the proportion of its high and low frequency components, yielding any noise character from the rumble of thunder to the hiss of steam.

In addition to a basic frequency change, there are some other options for the pulse waveform. With the 12 bits of control

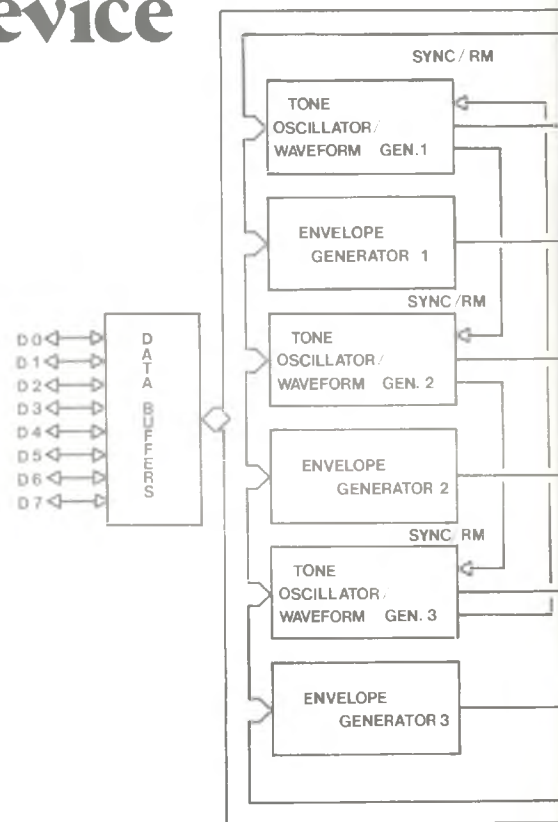

6581 SID BLOCK DIAGRAM

afforded by combining the HI and LO Pulse Width registers (creating a value similar to that of the Frequency registers), a desired pulse width or duty cycle may be defined for the pulse waveform. A linear range of duty cycle values, from constant DC to squarewave (including all values between 0 and 50% duty cycle), will give the pulse wave a "thinner" or "thicker" character. The pulse width range may be swept without discernible steps.

**ADSR capabilities.** While a good command of frequency and noise content is essential to realistic sound synthesis, overall timbre is even more important. And, would you believe that this chip has full ADSR capabilities to



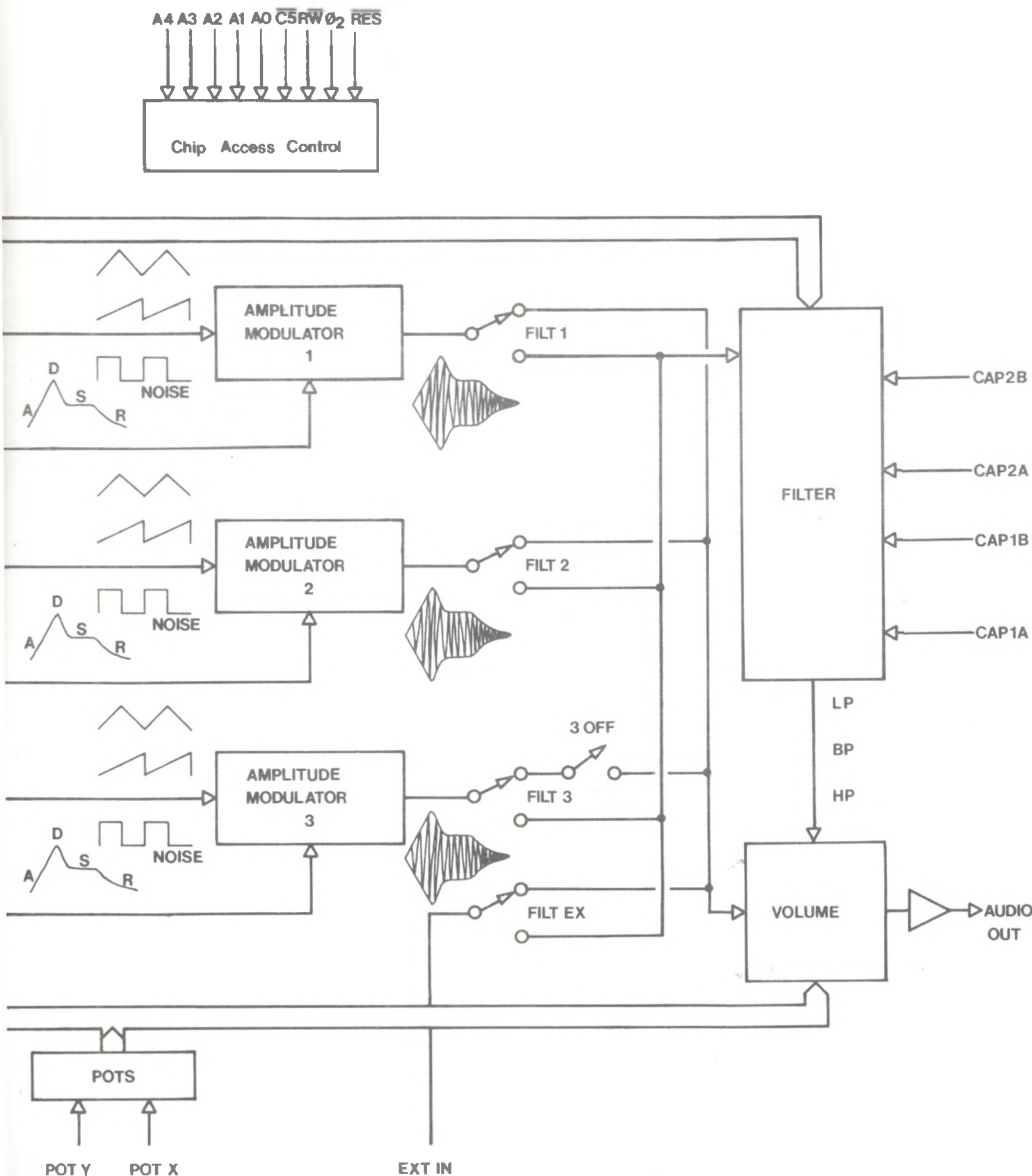

handle that!

SID's Attack/Decay and Sustain/Release Registers provide an exponential response (the kind our ears react to), in the way that a sound effect's loudness builds up to a maximum level (attack), falls from that level (decay), sustains at some lesser level, and then is released so that it fades away. Four bits (16 possible values) for each parameter allow a range of 2 milliseconds to 8 seconds for A/D, and 6 milliseconds to 24 seconds for S/R times. Each of the three voices may have its own unique ADSR values. Each voice's ADSR cycle may be initiated (triggered) or terminated via a Gate bit that is located in that voice's Control Register. Musical notes or sounds

may be held indefinitely at the sustain level if desired, and multiple Gate changes will cause attack and release sequences that can create very complex amplitude envelopes. An additional 4 bit (16 values) Volume register may also change the total audio output volume (the combination of all three voices) from mute to full volume. Altering the volume can modify the magnitude of the ADSR levels or provide amplitude domain effects, such as tremolo.

**SID's accessories.** With all of these possible combinations of voice and timbre, SID is more than an even match for some of the other sound chips in terms of versatility. Even so, SID boasts

a few more features that help it leave the others far behind. For instance, the Control Registers have a Sync bit that, when set, synchronizes the fundamental frequencies of any two oscillators for the much desired harmonic Hard Sync effect found in modern synthesizers. A similar Control bit is the Test bit, which, when reset, causes the selected waveform to start from its zero level. Not only is this an exact method of synchronization, but, under the guidance of proper real time software, enables the subtle influences of complex phase or frequency modulation. Such abilities could re-create the fine characteristic changes found in the first few waveform cycles of some natural musical instruments; these changes are exceedingly difficult to synthesize with any other method. Another Control bit causes one oscillator to be ring modulated by the frequency of another oscillator. This technique can produce non-harmonic, gong-type sounds. Like ring modulation, two of SID's register level features also mimic their analog synthesizer counterparts in digital format.

The Osc 3/Random and Env 3 Registers are byte sized windows into Oscillator 3's world of passing numbers. By reading the values in these registers, the computer (or human) is able to follow the rise and fall of the third Oscillator waveform or envelope. If the Osc 3 Waveform was, for example, a low frequency triangle wave, the Random Register would present a series of slowly increasing, then decreasing, numbers (representing the instantaneous amplitude of the triangle waveform as it cycles). If the computer took this value and placed it into the Frequency Register of some other oscillator, the effect would be frequency modulation (or sweeps) of that Oscillator by the waveform and frequency of Oscillator 3 -- just like the LFO modulation in an analog synthesizer. If Oscillator 3 was set to the Pulse waveform of varying duty cycle, the result would be pulse width modulation (PWM). If a noise waveform is used, the effect will be that of random sample-and-hold. Likewise, the Env 3 Register will represent the values of Oscillator 3's ADSR cycle. Applying this information to some other voice would simulate an analog envelope follower.

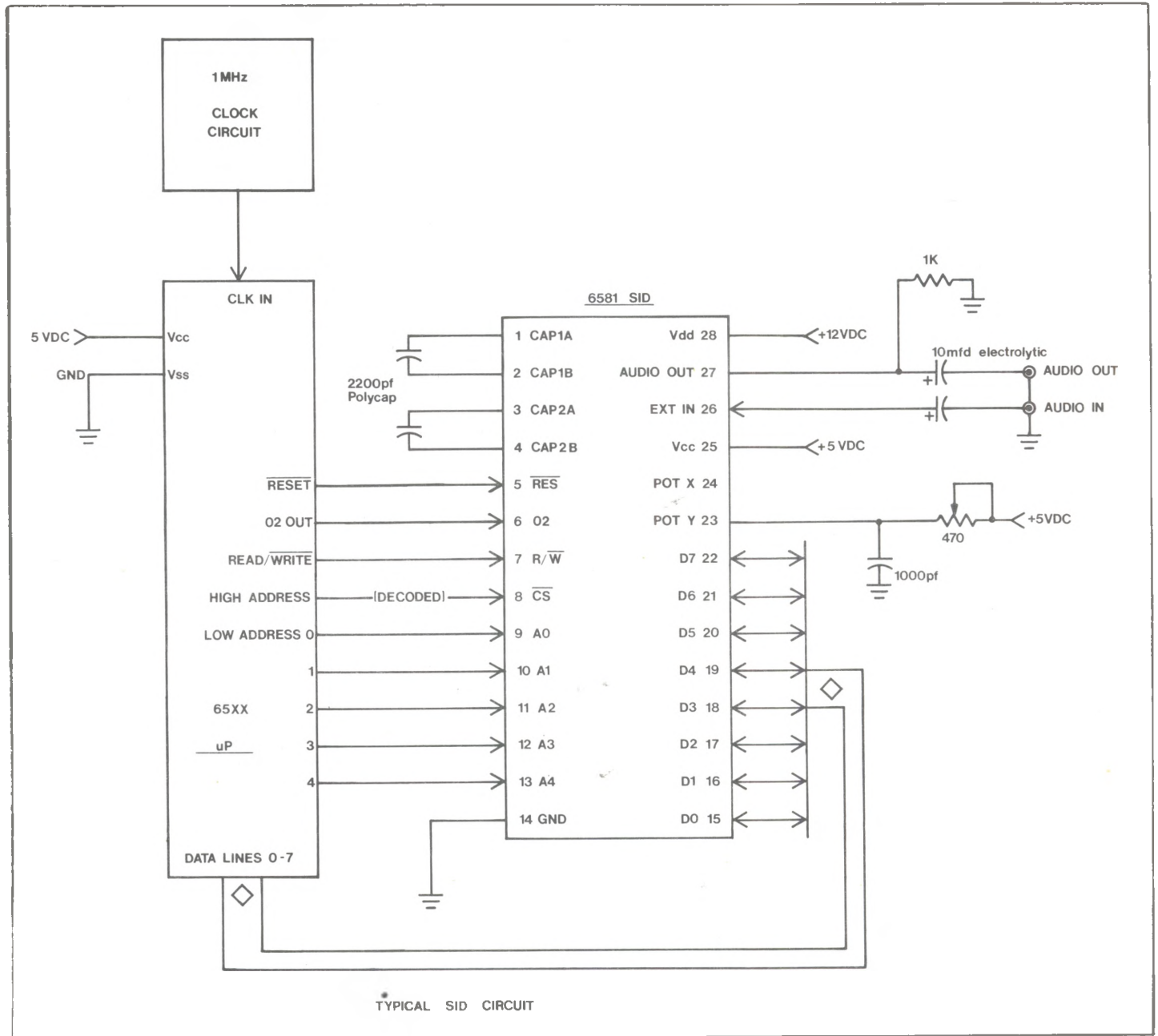

**SID's filter.** Some audio integrated circuits are sound sources, some are sound processors -- but SID is both. Two Registers, FC HI and LO, when combined, produce an 11 bit number that defines the linear range of cutoff or center frequency values for a digitally programmable audio filter. Using the suggested 2000 pF capacitor results in a cutoff frequency range from 30 Hz to 10 KHz. The 4 bit Res/Filt register may take one of 16 values to determine the amount of resonance or "peaking" of frequencies at the filter cutoff frequency. The bits in the Mode/Vol Register determine the type of filter mode: 12 dB/octave low pass, 6 dB/octave band-

pass or 12 dB/octave high pass. Any combination of the filter modes can be used; for example, combining LP and HP responses produces a notch response. Of course, sweeping the resonance or center frequency values through their ranges with a sound source present will give the expected "swoosh" or wa-wa effects.

Which sound sources can be filtered? Three bits in the Res/Filt Register select any of the aforementioned voices, but best of all, a 4th bit selects an external audio input. This option is what really gives SID the edge over its brethren. Any combination of generated sound voices and external control may be combined and fil-

tered, then sent to a single audio output (which is governed by a master volume control). The ability to take an external audio signal, then filter and/or alter the timbre (via the volume register) under real time computer control has great potential for some astounding sound or scientific uses.

Speaking of control, there are two more SID control points of note, especially if you don't like to push buttons! These are the POTX and POTY pins, which act as analog to digital converter (A/D) inputs. With +5V DC, a capacitor, and resistor (potentiometer) connected to POTX and/or POTY, a register value (0 to 255) propor-

### SID CONTROL REGISTERS

There are 29 eight-bit registers in SID which control the generation of sound. These registers are either WRITE-only or READ-only and are listed below in Table 1.

ADDRESS						REG # (HEX)	DATA								REG NAME	REG TYPE
A4	A3	A2	A1	A0	D7		D6	D5	D4	D3	D2	D1	D0			
0	0	0	0	0	0	00	F7	F6	F5	F4	F3	F2	F1	F0	VOICE 1	
1	0	0	0	0	1	01	F15	F14	F13	F12	F11	F10	F9	F8	FREQ LO	WRITE-ONLY
2	0	0	0	1	0	02	PW7	PW6	PW5	PW4	PW3	PW2	PW1	PW0	FREQ HI	WRITE-ONLY
3	0	0	0	1	1	03	-	-	-	-	PW11	PW10	PW9	PW8	PW LO	WRITE-ONLY
4	0	0	1	0	0	04	NOISE	-	-	-	TEST	RING MOD	SYNC	GATE	PW HI	WRITE-ONLY
5	0	0	1	0	1	05	ATK3	ATK2	ATK1	ATK0	DCY3	DCY2	DCY1	DCY0	CONTROL REG	WRITE-ONLY
6	0	0	1	1	0	06	STN3	STN2	STN1	STN0	RLS3	RLS2	RLS1	RLS0	ATTACK/DECAY	WRITE-ONLY
															SUSTAIN/RELEASE	WRITE-ONLY
7	0	0	1	1	1	07	F7	F6	F5	F4	F3	F2	F1	F0	VOICE 2	
8	0	1	0	0	0	08	F15	F14	F13	F12	F11	F10	F9	F8	FREQ LO	WRITE-ONLY
9	0	1	0	0	1	09	PW7	PW6	PW5	PW4	PW3	PW2	PW1	PW0	FREQ HI	WRITE-ONLY
10	0	1	0	1	0	0A	-	-	-	-	PW11	PW10	PW9	PW8	PW LO	WRITE-ONLY
11	0	1	0	1	1	0B	NOISE	-	-	-	TEST	RING MOD	SYNC	GATE	PW HI	WRITE-ONLY
12	0	1	1	0	0	0C	ATK3	ATK2	ATK1	ATK0	DCY3	DCY2	DCY1	DCY0	CONTROL REG	WRITE-ONLY
13	0	1	1	0	1	0D	STN3	STN2	STN1	STN0	RLS3	RLS2	RLS1	RLS0	ATTACK/DECAY	WRITE-ONLY
															SUSTAIN/RELEASE	WRITE-ONLY
14	0	1	1	1	0	0E	F7	F6	F5	F4	F3	F2	F1	F0	VOICE 3	
15	0	1	1	1	1	0F	F15	F14	F13	F12	F11	F10	F9	F8	FREQ LO	WRITE-ONLY
16	1	0	0	0	0	10	PW7	PW6	PW5	PW4	PW3	PW2	PW1	PW0	FREQ HI	WRITE-ONLY
17	1	00	0	0	1	11	-	-	-	-	PW11	PW10	PW9	PW8	PW LO	WRITE-ONLY
18	1	0	0	1	0	12	NOISE	-	-	-	TEST	RING MOD	SYNC	GATE	PW HI	WRITE-ONLY
19	1	0	0	1	1	13	ATK3	ATK2	ATK1	ATK0	DCY3	DCY2	DCY1	DCY0	CONTROL REG	WRITE-ONLY
20	1	0	1	0	0	14	STN3	STN2	STN1	STN0	RLS3	RLS2	RLS1	RLS0	ATTACK/DECAY	WRITE-ONLY
															SUSTAIN/RELEASE	WRITE-ONLY
21	1	0	1	0	1	15	-	-	-	-	-	FC2	FC1	FC0	FILTER	
22	1	0	1	1	0	16	FC10	FC9	FC8	FC7	FC6	FC5	FC4	FC3	FC LO	WRITE-ONLY
23	1	0	1	1	1	17	RES3	RES2	RES1	RES0	FILTEx	FILT3	FILT2	FILT1	FC HI	WRITE-ONLY
24	1	1	0	0	0	18	3 OFF	HP	BP	LP	VOL3	VOL2	VOL1	VoLo	RES/FILT	WRITE-ONLY
															MODE/VOL	WRITE-ONLY
25	1	1	0	0	1	19	PX7	PX6	PX5	PX4	PX3	PX2	PX1	PX0	MISC	
26	1	1	0	1	0	1A	PY7	PY6	PY5	PY4	PY3	PY2	PY1	PY0	POTX	READ-ONLY
27	1	1	0	1	1	1B	O7	O6	O5	O4	O3	O2	O1	O0	POTY	READ-ONLY
28	1	1	1	0	0	1C	E7	E6	E5	E4	E3	E2	E1	E0	OSC/RANDOM	READ-ONLY
															ENV3	READ-ONLY

TABLE 1 - SID REGISTER MAP

tional to the resistance setting of the potentiometer may be read by the computer, and subsequently used as control or data information. Since the value from this input is updated every 512 clock cycles, it may not be fast enough for speech processing, but should be more than adequate for use with a synthesizer front panel control knob or 2 axis joystick input control.

Another thing to note is that the SID External Input and Audio Output should be capacitor coupled, and that the signals are 3V p-p maximum and ride on a 6V DC bias level.

As a Commodore 64 computer owner, I am delighted that its design includes a plug connection for SID's direct audio output and external input so that I can get out high quality sound (and process an audio input), without having to modify the computer.

(The 64K of RAM memory, great VIC video graphics, joystick, and other interface ports are useful too!) But you don't have to use the Commodore 64K; by now, I'm sure you'll agree that a SID and any computer would make beautiful music together.

As raw material, the 6581 Sound Interface Device combines the best in additive (oscillator) and subtractive (filter) synthesis with digital control value. It's not an understatement if I say that when using the SID as a component in a larger audio system, your imagination will be challenged by Commodore MOS Technology's design. As some examples, just consider the filter applications for guitar effects, digital recording front ends, or vocoders. And I'm sure more than one person came up with this equation: (3 voice oscillator ADSR) + (3 voice oscillator ADSR) + computer = 1

great 6 string guitar synthesizer. Need I mention the straightforward digital mono/poly/portable keyboard synths? Did I hear someone say "speech synthesizer"?

SID, I think you made some new friends!

### Parts Availability

The Commodore MOS 6581 SID (Sound Interface Device) is available from Falk Baker Associates, 382 Franklin, Nutley, NJ 07110 (telephone 201-661-2430). Price is \$17.50 plus \$1.50 postage. For data, try MOS Technology Inc., 950 Rittenhouse Rd., Norristown, PA 19103.

Legal corner: Apple, Atari, Commodore, and MOS Technology are all trademarks of their respective companies.

# Log Response Voltage Controlled LFO

By: Craig Anderton

We all know about the advantages of voltage controlled, exponential response VCOs. What is less well known are the advantages of voltage controlled, exponential response LFOs -- especially when dealing with wide-range LFOs. Exponential response LFOs have a smoother sweep than the linear variety, and are more "natural-sounding" from a musical standpoint.

The "Hyperflange + Chorus" takes one approach to an exponential response VC LFO. That application called for a wide-range, voltage controllable LFO, capable of producing unusual waveforms specifically suited to delay line applications; the CEM3340 was a perfect chip for this circuit. However, what if you only need a "utility" log response LFO? For less critical applications, a super-precision, expensive chip like the CEM3340 would be overkill.

This article covers an exponential response VC LFO based on Exar's inexpensive, and widely available, XR2209. It generates square and either triangle or sawtooth waveforms, accepts a standard 0 to +10V control voltage input, and delivers a standard 0 to +10V output.

**How it works.** Figure 1 shows the schematic. IC1 provides the basic waveform generation function; IC2 provides the exponential control response; IC3 is a control voltage mixer; and IC4 provides level

shifting for the triangle wave output. Q3 accepts a synchro-sonic reset trigger to reset the LFO, which is a very powerful feature.

The VC LFO accepts a standard +15V power supply. Note that the 2209 is treated like a single-supply device running from +15V. This is important, since the device cannot accept 30 Volts across its supply terminals.

You can use just about any kind of op amp for IC2-IC4. A FET input type would probably be more precise, but we're aiming for low cost so you might as well use a 741 or whatever else is handy. The one concession to accuracy is C4 and C5. I would suggest using tantalum (rather than more easily obtainable electrolytic) capacitors for best frequency stability.

**Calibration.** Calibrating the VC LFO can be easily done with a VOM or 'scope. First, ground the control voltage inputs, then hook your meter or 'scope probe to pin 8 of IC1, and make sure that S1 is in the triangle wave position. Next, adjust R18 so that the circuit just kicks into oscillation. This will be a very slow frequency, so watch your meter or scope trace carefully for signs that the LFO is coming to life.

Now feed a +10V control voltage into the CV input, and adjust R14 for the highest possible frequency. Note that when you get past a certain point, the frequency will actually decrease, or perhaps become erratic. You want the highest frequency short of this erratic point.

Finally, clip your probe to IC4's output. If you're using a VOM, the following calibration will be somewhat difficult since you'll have to set the LFO for a low frequency to minimize meter "overshoot". A 'scope is a better choice for this part of the calibration. In any event, adjust R19 for a 10V peak-to-peak output, then adjust R11 so that the bottom tip of the triangle wave touches ground, and the peak reaches +10V. The VC LFO is now calibrated.

**Using the VC LFO.** There's not much too it -- choose either the triangle or sawtooth output with S1 (note that the square wave output is available simultaneously), apply a suitable voltage to the CV input to set the operating frequency, and you're ready to go. The sync input, compatible with the "Master Synchronizer" PAIA module I described in the February 1983 issue of Keyboard magazine, resets the LFO upon receiving a sync pulse in the range of +5 to +10V. This is handy for synchro-sonic techniques, such as rhythmic vibrato.

That's all there is to the VC LFO. It's inexpensive, useful, simple to build, and most of all, it has a smooth exponential response which is musically useful.

**Acknowledgement.** I'd like to thank Ron Dow for turning me on to the XR2209, and for showing me the exponential control cell built around IC2.

figure 1

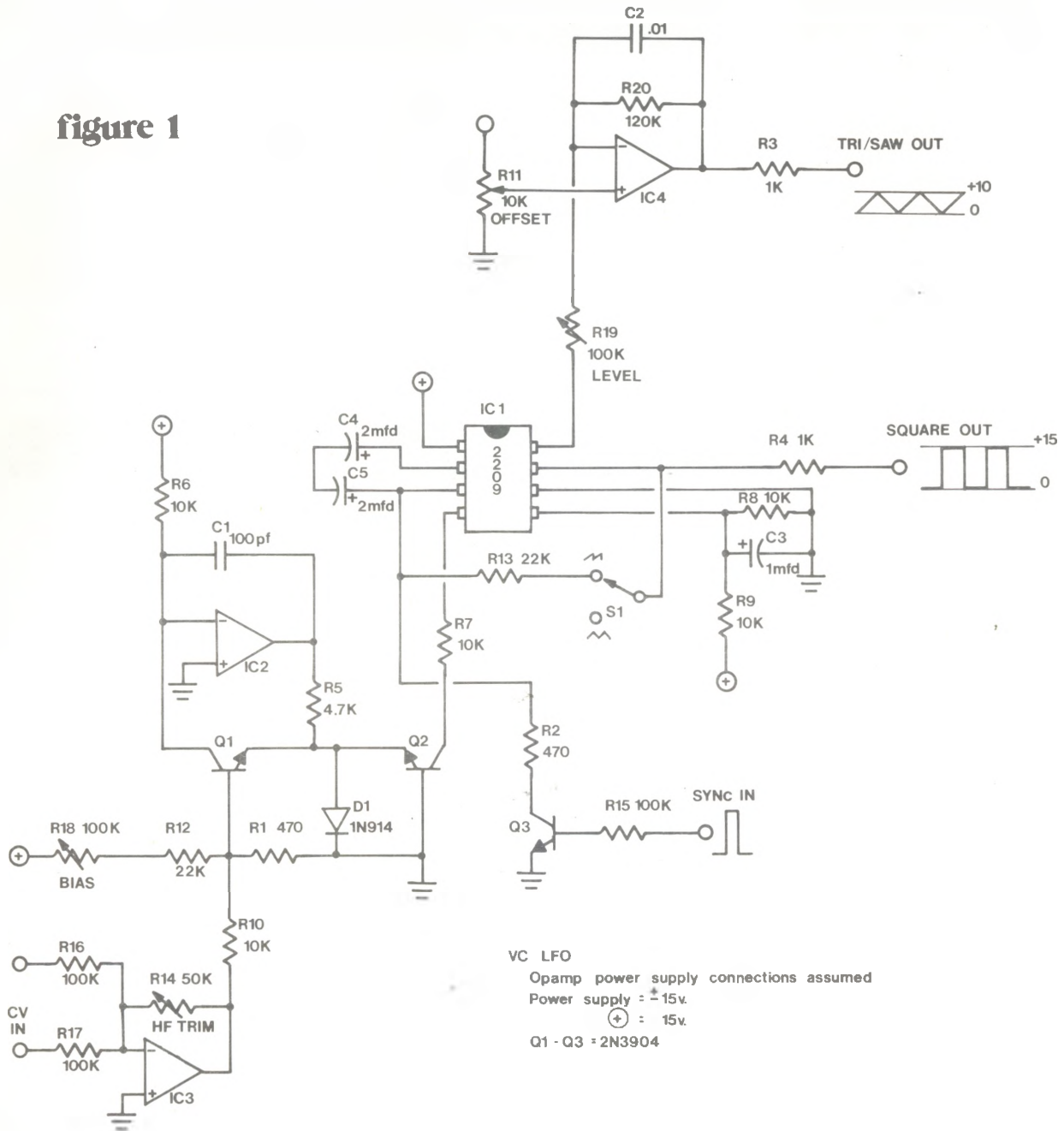

Parts List

Resistors (5% or 10%, 1/4 Watt)

R1, R2	470 Ohms
R3, R4	1k
R5	4.7k
R6 - R10	10k
R11	10k trimpot
R12, R13	22k
R14	50k trimpot
R15 - R17	100k
R18, R19	100k trimpot
R20	120k

Capacitors

C1	100 pF
C2	0.01 uF
C3	1 uF electrolytic
C4, C5	2 uF tantalum

Semiconductors

D1	1N914 or equiv.
IC1	XR2209 VCO
IC2 - IC4	741 (see text)
Q1 - Q3	2N3904

Mechanical parts

S1	SPDT switch
Misc.	Jacks, circuit board, etc.

# Letters

continued from page 31 .....

Terrance -- If you're going to substitute op amps, you have to be careful. First, the pinout of the two parts is different; if you didn't take this into account, there could be problems. Also, the 324 is designed for single supply operation, while the 4136 works off bipolar supplies. Power supply hookups are also different for the two chips. Always use the parts specified for a project unless you really know what you're doing. As far as driving headphones, most op amps will drive high-sensitivity headphones, but the volume level will not be overwhelming.

## GUITAR WIRING TIP

I'm a radio announcer as well as being an active musician and recordist. Something that guitar companies ought to pick up from the radio and recording industry is the use of two-lead shielded cable as the audio run inside bodies. You've seen the stuff; it's commonly used for low impedance audio line, and is great for guitar electronics. With that cable, loss is minimal, adding a phase switch is a breeze without messing around soldering tiny wires to shield jackets, and with a little ingenuity, you could add a dual ganged pot (hot and ground leads reversed with respect to each other) to create a classy little phase mixer. Next time you need to re-wire a guitar, take a crack at this stuff. I'm having a ball with it.

Al Peterson  
Huntington, MA

# EQUIPMENT EXCHANGE

PUT POLYPHONY TO WORK FOR YOU. List equipment for sale or trade, job openings, positions wanted, etc. Equipment exchange classified rates for individuals offering goods or services for sale or trade: 25c per word, 20 word (\$5.00) minimum charge; Commercial establishments: 50c per word. Prices, zip, phone numbers count as one word each. DISPLAY CLASSIFIED: \$15.00 per inch, one inch minimum, camera ready art to be supplied by advertiser. All classified advertising must be prepaid. Advertisers using a post office Box number for responses must furnish Polyphony Publishing Co. with a complete street address and phone number. Readers should respond directly to advertiser. Polyphony is not responsible for claims made in ads, or for the results of any transactions. Polyphony reserves the right to edit or refuse any ads submitted.

## Music equipment

Synthi-AKS with velocity sensitive keyboard (DK-1) and sequencer keyboard. In excellent condition with extensive manuals and schematics. A rare and versatile instrument \$1,250. Electro-Harmonix Vocoder - Rack mount, sounds great, \$300. Walter Whitney (314) 429-2858.

ROLAND TR-808 programmable drum machine. Excellent condition, complete with manuals. Cost \$1,100, sell for \$600. David Shumate, 4267 N.E. 124th St. Seattle, WA 98125 (206) 362-3239.

ROAD KEYBOARD, Phlanger, and many PAIA 2720 series modules. Some work, some don't. Write for details: Tom Marohn, 329 LaVeta Pass St., Golden, CO 80401

## Recordings

KEY ESSENTIALS cassette by Bill Rhodes. Polys, Piano, and Pipe Organ in a "Symphonic" Genre. \$6.00 to Jazzical Records, Suite "A", 1392 N. Killian Dr., Lake Park, FL 33403

1,000,000 SOUNDTRACK/CAST LPs! Catalogue --\$1.00. RTSP, Box 10687, Costa Mesa, CA 92627. Soundtrack Value Guide -- \$5.50. Original Cast/TV Value Guide -- \$5.50. Personalities too!

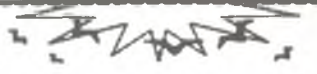
  
**★★★NOW.....**  
 ON C60 CASSETTE:  
**SYNTHETIC FOUR**  
**ELECTRONIC MUSIC**

---

*If you like the style of Larry Fast and Patrick Gleason:  
 Try the style of:*  
**SYNTHETIC FOUR**  
 \$4.95 to -----

Steve Meehler  
 1610 J Ave NE  
 Cedar Rapids, IA 52402

# AD INDEX

Dickstein Distributing Co. ....	25	PGS Electronics .....	39
Gentle Electric .....	4	PAIA Electronics .....	2, 4, 5, 40
Jensen Tools .....	5	POLYMART .....	20, 21, 22
Larson Music Co. ....	15	Telex .....	9
Musitech .....	28	Unique Vinyl .....	6

## LINEARS

TL061.....BiFet.....	.72
TL062.....Dual BiFet.....	.99
TL064.....Quad BiFet.....	1.95
TL071.....BiFet.....	.65
TL072.....Dual BiFet.....	1.15
TL074.....Quad BiFet.....	1.95
NE555.....Timer.....	.39
NE570.....Compannder.....	3.80
NE571.....Compannder.....	2.95
NE572.....Compannder.....	4.95
UA741.....Comp. OpAmp.....	.29
MC1456.....Low Noise OpAmp.....	.90
RC1556.....Low Noise OpAmp.....	1.48
CA3080.....OTA.....	.94
CA3280.....Dual OTA.....	1.98
RC4136.....Quad OpAmp.....	1.10
RC4739.....Dual Low Noise.....	1.19
NE5532.....Dual High Perf.....	3.70
NE5534.....High Performance.....	2.65

## SPECIAL PURPOSE

SAD-1024.....Analog Delay.....	17.50
SAD-4096.....Analog Delay.....	37.50
MK50240.....Top Octave Div.....	5.95
SN76477.....Sound Generator.....	3.45

## SANYO HYBRID POWER AMPS

STK050.....50 Watt Power Amp.....	19.40
STK070.....70 Watt Power Amp.....	24.20

## SSM- SOLID STATE MICRO-TECHNOLOGY

SSM 2010.....VCA.....	7.50
SSM 2011.....PreAmp.....	5.75
SSM 2012.....VCA.....	9.50
SSM 2020.....VCA.....	7.50
SSM 2022.....VCA.....	7.50
SSM 2030.....VCO.....	7.50
SSM 2033.....VCO.....	10.00
SSM 2040.....VCF.....	7.50
SSM 2044.....VCF.....	7.50
SSM 2050.....VCTG.....	7.50
SSM 2056.....VCTG.....	5.75

## THERMISTER (Temp. Sensing Resistor)

TSR-Q81.....Tel Labs Q81 1k.....	\$3.50
----------------------------------	--------

## OPTO-ISOLATOR

CLM6000.....Clairex CLM6000.....	\$2.85
----------------------------------	--------

## CAPACITORS (25 volt)

701-100.....100 pf polystyrene.....	.25
701-180.....180 pf polystyrene.....	.25
701-1000.....1000 pf polystyrene.....	.25
701-2200.....2200 pf polystyrene.....	.25
701-2200.....3300 pf polystyrene.....	.25
701-3900.....3900 pf polystyrene.....	.25
702-005......005 uf mylar.....	.12
702-01......01 uf mylar.....	.12
702-05......05 uf mylar.....	.16
702-1......1 uf mylar.....	.21
702-22......22 uf mylar.....	.33
703-1.0.....1.0 uf tantalum.....	.39
703-3.3.....3.3 uf tantalum.....	.49
703-4.7.....4.7 uf tantalum.....	.59
704-2.2.....2.2 uf electrolytic.....	.21
704-4.7.....4.7 uf electrolytic.....	.21
704-10.....10 uf electrolytic.....	.21
704-100.....100 uf electrolytic.....	.31
705-10.....10 pf ceramic disk.....	.15
705-.01......01 uf ceramic disk.....	.12
705-1......1 uf ceramic disk.....	.17

## IC SOCKETS (solder tail)

IC-S-08.....8 pin high quality socket.....	.27
IC-S-14.....14 pin high quality socket.....	.30
IC-S-16.....16 pin high quality socket.....	.34
IC-S-18.....18 pin high quality socket.....	.40
IC-S-28.....28 pin high quality socket.....	.60
IC-C-08.....8 pin economy socket.....	.13
IC-C-14.....14 pin economy socket.....	.15
IC-C-16.....16 pin economy socket.....	.17
IC-C-18.....18 pin economy socket.....	.20
IC-C-28.....28 pin economy socket.....	.40

## RESISTORS 5%, 1/4 watt

All EIA values available from 2.0 ohm to 5.1 Meg.  
Also available is 10 Meg.

100 each of same value.....	\$1.50
50 each of same value.....	.98
25 each of same value.....	.75
10 each of same value.....	.40
5 each of same value.....	.25

## ASSORTMENTS

10 each of 10 values (100).....	3.00
25 each of 10 values (250).....	6.50
50 each of 20 values (1000).....	16.00

## CHORUS / DELAY KIT

This chorus/delay unit, designed by Craig Anderton and featured in Guitar Player magazine, provides flanging, slapback echo, and automatic double tracking effects. The delay range is from 2 ms to 80 ms. Due to the use of compression and expansion techniques, the unit has dead-quiet operation up to about 50 ms and only minimal noise out the full 80 ms. This project kit consists of all electronics, pots, jacks, etc. Also included are the two circuit boards (etched, drilled, and legended) needed for the project. Not included is wire, solder, case, knobs, etc. The Chorus/Delay unit also needs a well regulated bi-polar 15 volt power supply (not included). (A punched and legended rack mount panel will soon be available for this project.)

Order KT-CD777..... \$78.00

## "SNARE +" DRUM VOICE KIT

This percussion synthesizer was designed by Thomas Henry and appeared in POLYPHONY magazine. Here's what Craig Anderton had to say about the "SNARE +": "At last - an inexpensive drum voice that has a punchy, full sound. All in all, the Snare + delivers a lot of drum sounds, and I would unhesitatingly recommend it to anybody who's tired of the thin sound found in most electronic drum units."

We offer the kit with or without a panel. Kit 3770 contains all electronic parts, switches, jacks, pots, etc, as well as etched, drilled, and legended circuit board. Kit 3772 includes all this plus a punched and legended rack mount panel (standard 1 3/4 by 19 inches) available in black or blue (both with white legends).

Not included with either kit is wire, solder, mounting hardware, etc. The SNARE + also needs a bi-polar 15 volt power supply (not supplied).

KIT 3770 Basic SNARE + kit..... \$33.95  
KIT 3772 SNARE + with rack panel... \$44.94

## THE "CLARIFIER" GUITAR EQ/PREAMP

The "CLARIFIER" is an onboard preamp/EQ module for guitar. This design, by Craig Anderton, was first seen in the pages of GUITAR PLAYER magazine. Here's what the CLARIFIER will do: Replace the guitar's standard passive tone control with a two control, active circuit which provides over 12 db of bass and treble boost and up to 6 db cut. Buffer your pickups from external loading, giving additional output and improve high freq response. Add a nominal 6 db of gain to give your signal a bit more punch, as well as improve the signal/noise ratio in multiple effects systems... make your guitar immune to the high freq loss caused by long cable runs.

The CLARIFIER kit is available in two options, both of which include a high quality drilled, legended, and masked circuit board, as well as complete step by step instructions. Kit 2450 contains everything needed for a complete unit. Kit 2455 contains everything except the pots (for those who prefer a particular brand of potentiometer). Batteries are not included with either kit.

KIT 2450.....Complete CLARIFIER kit .. \$18.95  
KIT 2455.....CLARIFIER less controls ..\$14.95

**TERMS:** (Check, Money Order, Cashiers Check - Add .75 if under \$10.00) - (\$10.00 minimum on C.O.D. (UPS only) add \$1.50) - (Mastercard and Visa: \$10.00 minimum. You must supply exp. date.) - (Indiana residents add sales tax.)

**SHIPPING AND HANDLING:** \$1.00 plus 5% of purchase. We will credit any amount over our standard rate.

**SATISFACTION GUARANTEED!**

## SIGNAL DIODE

601-60...1N914 (1N4148) signal diode. 5/.35

## TRANSISTORS

2N3904.....2N3904 NPN Transistor.....	.25
2N3906.....2N2906 PNP Transistor.....	.25

## POTENTIOMETERS

(3/8 long shaft, 5/16 mounting hole)	
854-401.....10K Linear taper.....	1.09
854-501.....100K Linear taper.....	1.09
854-505.....500K Linear taper.....	1.09
855-401.....10K Audio taper.....	1.09
855-501.....100K Audio taper.....	1.09
855-505.....500K Audio taper.....	1.09
856-401.....10K Audio taper with on/off switch.....	1.25

## TRIM POTS (vertical mount)

802-251.....250 ohm trimmer.....	.40
802-103.....10K trimmer.....	.40

## MINI TOGGLE SWITCHES

403-20.....SPDT (on/on) sub-mini (3A).....	1.20
403-40.....DPDT (on/on) sub-mini (3A).....	1.50
405-10.....SPST (on/off) bat handle (6A).....	1.85

## LED's

Please note that the typical DC forward current (I-fwd) of these LED's is less than those offered elsewhere making these LED's ideal for battery circuits or others where current consumption is a factor.

305-201.....Red T-1 1/4 jumbo diffused (20 ma).....	.30
305-202.....Green T-1 1/4 jumbo diffused (30 ma).....	.40
305-203.....Dual T-1 1/4 jumbo diffused (50 ma).....	.90
305-204.....Tri T-1 1/4 jumbo diffused (20 ma).....	1.50

Note: 305-204 is a three lead, tri-color (green, red, yellow) device. It is essentially two separate LED's in one package. (The yellow is obtained by turning on both green and yellow.)

## JACKS and PLUGS

1/4 In. PHONE JACKS	
901-101.....Mono standard phone jack.....	.45
901-103.....Mono with n/closed contact.....	.52
901-105.....Mono encl. jack (open back).....	.55
902-211.....Stereo standard phone jack.....	.70
902-213.....Stereo encl. jack (open back).....	.77

1/8 In. MINI JACKS	
903-351.....Mono with n/closed contact.....	.32
903-353.....Mono encl. (open back).....	.26
903-355.....Mono enclosed with contact.....	.35

RCA JACKS	
921-100.....RCA jack, chassis mount.....	.34
921-200.....RCA jack on phenolic mount.....	.25
921-300.....Dual RCA on phenolic mount.....	.43

1/4 In. PHONE PLUGS	
911-201.....Mono, black phone plug.....	.48
911-203.....Mono, red phone plug.....	.48
911-205.....Mono, chrome (metal) plug.....	.120
911-211.....Stereo, black phone plug.....	.65

1/8 In. MINI PLUGS	
913-251.....Mono, black mini plug.....	.38
913-253.....Mono, red mini plug.....	.38
913-255.....Mono, chrome (metal) plug.....	.56

## SWITCHING JACKS

These are stereo phone jacks that contain an independent switching system that is controlled by the insertion of the plug. Jack 905-301 contains the equivalent of a DPST normally on switch. Jack 905-302 contains the equivalent of a DPDT on/on switch making it ideal for switching bi-polar power supplies on and off in effects boxes, etc.

905-301.....Stereo jack with SPST switch.....	.90
905-302.....Stereo jack with DPDT sw.....	1.00

**PGS ELECTRONICS**  
Route 25 - Box 304  
Terre Haute, IN 47802

# PROTEUS I <sup>T.M.</sup>

**PROGRAMMABLE PRESET  
LEAD SYNTHESIZER**

**NOW AT A NEW  
LOW PRICE**

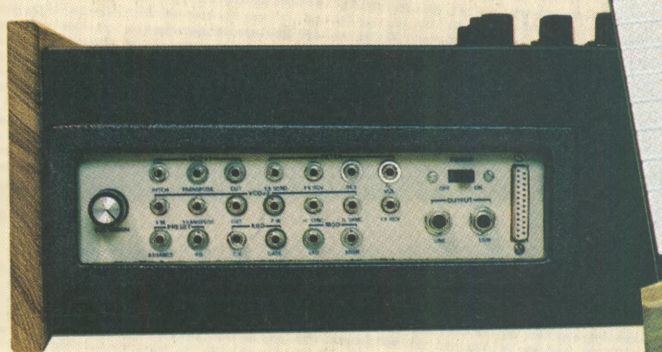

We had a lot of ambitious goals in mind when we began designing the Proteus I synthesizer.

We wanted, first of all, to provide a quality piece of equipment that would offer wide range precision and quiet, pure performance. So we designed Proteus around the world recognized Curtis Electromusic Chip Set to realize Oscillators and Filter with 12 octave range, transient generator segments out to 30 seconds long, exceptionally low noise and clean sound. Qualities you need for serious production work.

We wanted it to be easy to use on stage or in the studio. A keyboard that would let you get just the sound you wanted RIGHT NOW, without a lot of knob twiddling and switch throwing. So we gave Proteus 16 presets and simple controls that let you quickly and easily step from one preset to another or instantly switch between presets.

We knew you wouldn't want you to be locked into factory canned presets so we added an easy programming facility that let's you play with the sound and develop just the tone color, texture and feeling that you're after before saving the setting of every knob and switch with the push of a single button. And Proteus's internal memory keep-alive battery means that the preset will still be there even after months of power-down storage.

We knew that any normalization plan, no matter how clever and well planned, must in subtle ways define and restrict the kinds of sounds that a synthesizer can make. So after spending months developing and refining an exceptionally versatile normalization plan, we added the most liberal collection of patch over hardwire points that you'll find on any synthesizer. The patch bay lets you integrate external processing elements into Proteus's signal path. Or interface to a wide variety of analog controllers like sequencers and function generators. Or

use optional footswitches to control preset functions. Or respond tomorrow to needs that you can't even imagine today.

We wanted Proteus to have a computer port that would set the standard for versatility and ease of use. While the interfacing provisions of some synthesizers are "tacked on", forcing you to choose between keyboard or computer control (but not both) and forget about front panel controls completely. The Proteus interface doesn't put the computer between you and your music. It puts the computer where it belongs, at your side to help when you want it to store or retrieve presets or keyboard sequences and completely out of the way when you don't want it. There aren't even any switches to throw, to use the computer, just plug it in.

We wanted to design a piece of equipment that despite its high-tech complexity would be easy to assemble and service, so we broke assembly down into small easily digested chunks with simple tests along the way that lets you monitor your progress and go from step to step with complete confidence.

To get the full details on the power and versatility of PROTEUS, send for your PROTEUS Using/Assembly Manual today and you'll also receive Craig Anderton's 20 minute demonstration cassette, [the cassette alone is worth the price] \$10 refundable on kit purchase.

ORDER TOLL FREE WITH VISA OR MASTERCARD

**1-800-654-8657**

I-8750 PROTEUS MANUAL ..... \$10 postpaid

8750 PROTEUS I KIT was ~~\$499~~ now \$399 (26lbs.)

Direct mail orders & inquiries to:

**PAIA Electronics, Inc.**

1020 W. Wilshire · Oklahoma City, OK 73116 - (405)843-9626