

June 1983

# Polyphony<sup>T.M.</sup>

*ELECTRONICS - MUSIC - HOME RECORDING*

\$2.50

## MIDI

**HARDWARE  
FUNDAMENTALS**

**WHAT IT MEANS  
FOR MUSICIANS**



**THE VANGELIS INTERVIEW**

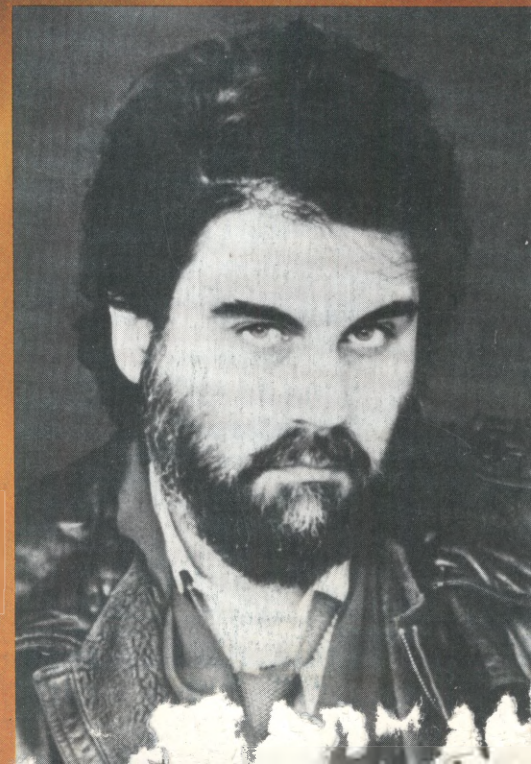

*ISSN: 0163-4534*



# EXPLORE THE WORLDS

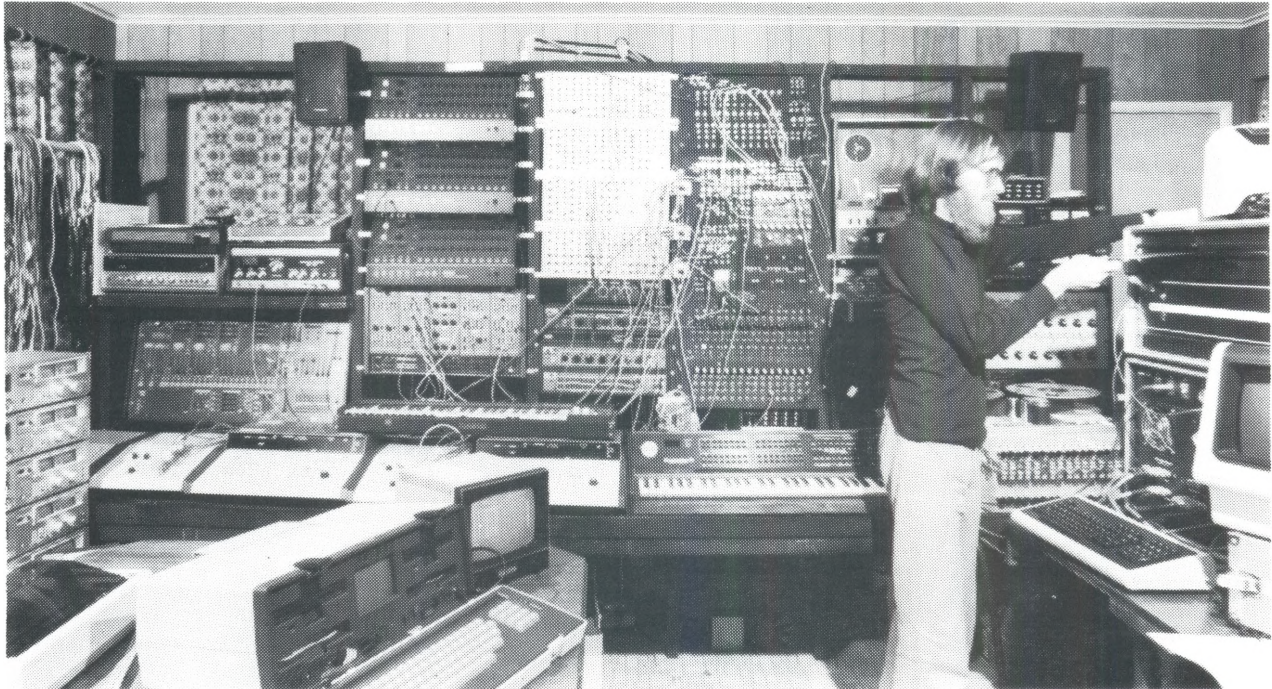

one of the world's largest private computer music laboratories.

# OF COMPUTER MUSIC

Did you think you've "heard it all" when it comes to computer music? **THINK AGAIN.** Think about full bodied choral and orchestral music or arabic sounding heavy rock, or uncannily realistic East Indian music or Japanese flute themes. Think about audio universes you can't even begin to imagine, derived from a combination of synthesis and digitization of real sounds, such as voices, instruments, whales and much more. In fact think about all the music of mankind through the ages blended into textures and compositions never before possible, all rendered 100% under program control. **THINK SYNTHESIS IN ITS BROADEST MEANING. THINK MACROFUSION®.**

Send \$3 for half hour sampler cassette and descriptive color catalog for 12 other cassettes.

**MACROFUSION®** COMPUTER  
MUSIC

40879 Hwy 41 Suite 12-b  
Oakhurst, CA 93644



# STAFF

## PUBLISHER

John S. Simonton, Jr.

## EDITOR

Craig Anderton

## MANAGING EDITOR

Linda Kay Brumfield

## TECHNICAL ILLUSTRATOR

Caroline Wood

## CIRCULATION

Ramona French  
Peggy Walker

## BOOKEEPING

Cathi Boggs

## PRINT PRODUCTION

Phuong Nguyen  
SEMCO Color Press

POLYPHONY (ISSN 0163-4534) is published bimonthly at 1020 W. Wilshire Blvd., Oklahoma City, OK 73116, by Polyphony Publishing Co. Entire contents copyright (c) 1982 by Polyphony Publishing Co. All rights reserved. No portion of this publication may be reproduced in any manner without written permission from the publisher. Second Class postage is paid at Oklahoma City, OK 73125.

ADVERTISING rate card and deadline schedule is available upon request. Contact Linda Brumfield at (405) 842-5480.

DEALERS & DISTRIBUTORS bulk prices are available upon request. Contact Linda Brumfield at (405) 842-5480.

SUBSCRIPTION rates:  
American 1 year \$12.00  
2 years \$22.00  
Foreign 1 year \$14.00  
2 years \$26.00

We now accept MasterCharge and Visa payment for subscriptions, back issues, and PolyMart items. Foreign payments must be by charge card, money order, or certified check in US funds drawn on a US bank.

BACK ISSUES are available at \$2.50 each ppd. Send SASE and request our 'Back Issue List' for a complete index of issues and their features, or see the back issue ad in this issue.

CHANGE OF ADDRESS notifications must include your former address and zip code, and any numbers from the mailing label, as well as your new address. When you move, be sure to notify your post office that you DO want second class and controlled circulation publications forwarded. This will save lost or returned issues. Polyphony is not responsible for replacement of lost or returned issues when we have not been supplied with change of address information.

TO POSTMASTER, send address changes to:

POLYPHONY  
PO Box 20305  
Oklahoma City, OK 73156  
Ph. (405) 842-5480

# CONTENTS

ISSN: 0163-4534

## Polyphony

Volume 8, Number 4

June, 1983

## FEATURES

Creative Recording on a Shoestring Budget by: Delton Horn .....	16
An Electronic Switch For Musicians by: David diFrancesco .....	19
MIDI Hardware Fundamentals by: Stanley Junglieb .....	34
MXR Omni effects system a Review by: Peter Montgomery .....	39
The Vangelis Interview by: John K. Diliberto .....	20
What MIDI Means For Musicians by: Jim Wright .....	8

## COLUMNS

Applied Synthesis: Poly-61 Review by: Bill Rhodes .....	41
Book Review: The Complete Synthesizer by: David Doty .....	32
On Location: Alaska by: Dale Stirling .....	5
Practical Circuitry: One Chip ADSR by: Tom Henry .....	30
Re-View by: Robert Carlberg .....	6

## REGULARS

Ad Index .....	42
Current Events .....	25
Editors Note .....	7
Equipment Exchange (classifieds) .....	42
Letters .....	4

Cover Photography: Linda Kay Brumfield "The MIDI Connection"  
Vangelis Photo courtesy PolyGram Records



# Letters

## UPDATES/CORRECTIONS

Re: My "Meet SID" article, here's some additional information of interest. In 1983, Commodore will release a "synthesizer" keyboard containing 3 additional SID chips as an add-on for the Commodore 64 computer, making it a 12 voice synth. Add-on price is slated to be under \$100. Also, expect a 3 head drum unit (plus software) to produce electronic percussion as an under-\$60 add-on to the Commodore 64. Finally, readers might like to know that the 64 is now available for under \$230.

James Lisowski  
S. Milwaukee, WI

Referring to my article "Build a Bass Pedal System" in the April '83 issue, the parts list should read:

R5-R17, R33, R34 = 270k. Otherwise R6-R16 can't be accounted for. Q1-Q3 are 2N3906 or 2N5158 PNPs.

There are two different R45s listed. Referring to figure 4, the R45 connected to the main out and C25 should be R46. 220k is correct. The R45 connected to pin #2 of IC3 is 22k.

The parts shown in the dotted areas are located off the circuit board.

Finally, re the suggested pinouts, pins 1 & 2 of the edge connector and circuit board should be low voltage AC in as shown in figure 1.

I hope this clears up any questions, but I'd like to hear from any of you readers as to how this project worked out for you.

Steve Hawk  
Hawk Music Systems  
2011 W. 11th St.  
Upland, CA 91786

To keep Polyphony readers apprised of developments in an evolving design, here are some improvements to the original DTC

design presented in the February '83 issue:

1) Performance of the sustain and hold outputs can be improved by putting the first sample-and-hold (S/H) under control of the inverted gate and the second S/H under control of the trigger. The modification is most easily accomplished by removing R17 and R18, which can be eliminated from the circuit, making soldering points available. The pad which connects to pin 13 of IC2 is the control input to the first S/H -- route a wire from this location to one leg of R16. The pad which connects to pin 12 of IC2 is the control input to the second S/H -- route a wire from this location to the spare pad left from the removal of R17 where it was formerly connected to pin 4 of IC1. It is important to note that the trade-off for this improvement in performance is that the sustain and hold outputs will no longer be pressure sensing. If this type of response is desired, a pressure sensing signal will be available at pin 12 of IC3.

2) Further improvement in response of the sustain and hold outputs can be realized by using a 1 uF capacitor for C3, preferably tantalum. This will keep output levels constant for a much longer period of time. Those who purchase the DTC kits will find a 1 uF tantalum capacitor included in the parts bag.

3) Concerning the piezo transducer, I have found that about one transducer in five will have reversed polarity; that is, the device will respond with a negative-going excursion of the pulse preceding the positive-going excursion, resulting in poor DTC performance. If this happens, simply reverse the connections of the two leads that attach to the transducer and everything will come up right. Also, piezo transducers are now available to Polyphony readers from the address below for \$2.95; DTC circuit boards are available separately for \$4.95.

I would be interested in

hearing from any Polyphony readers who would care to relate their personal experiences in regards to the DTC module -- successes or failures, and new and interesting ways of using the device.

Bobby Beausoleil  
PO Box 1033  
Grover City, CA 93433

## NEW AGE NEWS

Thank you, Don Schwartz, for your wonderful article on new age music. Readers interested in hearing the "classical" works you mentioned by Wolff and Hennings, Paul Horn, and Tony Scott you may wish to receive a copy of The Wholistic Health Music Catalog, available from:

San Francisco Medical Research  
Foundation  
803 Fourth St., Suite 7  
San Rafael, CA 94901

Judging from the mixed bag of offerings, the SFMRF has a refreshingly broad notion of just what constitutes the "new age" sound. Among the sixty or so LPs and cassettes listed is everything from Lullaby from the Womb (recordings made near the head of an eighth-month-old fetus), to Balinese gamelan music, Miles Davis, and Terry Riley. As there are lots of surprises along the way, the catalog is delightful reading whether or not one plans to buy any records.

Tim Dowty  
San Diego, CA

## IS NEW AGE NEW?

I enjoyed Don Schwartz's overview of "New Age Music" in the Feb '83 issue. He does a good job of describing the similarities between diverse "New Age" artists.

He does not seem to acknowledge, however, that this attitude in music has cropped up periodically at least since the late 19th century. Wagner's proclamation of a new totally-involving music-drama spawned a counter-revolution of composers to whom music was simply music, to be enjoyed for itself and not theorized over. These included the English new-Renaissance composers Elger, Delius, and Vaughn Williams; the French Impressionists Debussy, Ravel, and Les Six; and scattered



# ON LOCATION:

# Alaska

BY: DALE STIRLING

Let it be known that synthesists in Alaska do not live in igloos. Seriously though, the development and growth of electronic music in the United States is reflected in the small but hardcore electronic "crowd" in Alaska. As a serious synthesist and collector of electronic music I have closely watched the involvement of Alaskans in the field of electronic music over the last decade. There is a growing awareness of the viability of electronic music in the mainstream of traditional musical styles.

With a population not exceeding 500,000 people, there are probably only 50 (at the outer limit) fans of electronic music, and even fewer of these own synthesizers, analog or digital, and compose electronic music. Part of the problem in acquiring an electronic instrument is the paucity of products available in the state. Only four music stores carry synthesizers, and of those four only six different brands of electronic gear are represented. For instance, if I wanted to order a modular Roland polyphonic system, I would have to go through an outside dealer, a practice that not only takes time but adds considerable cost in shipping and shipping charges; this tends to discourage the prospective buyer. But still we persevere. While in London in 1982, I purchased an Octave-Plateau Electronics Kitten II synthesizer; interestingly enough, it cost less for me to buy this synthesizer in England (about \$500) than it would for me to order it from the factory in New York while in Anchorage (it would have cost up to \$700). One dealer in Anchorage, though, is beginning to carry quite a thorough line of KORG products, and at what seems like stateside prices.

Aside from the difficulty in purchasing equipment in Alaska, there is a lack of electronic music LPs available in record stores. Anchorage has two record shops, both charging stiff prices, and neith-

er one carries much of an electronic music inventory. Thus, my annual trips to Seattle end up as record buying binges; why pay \$9.98 when you can pay \$7.98? I have hope for the future, however; Anchorage's population, and indeed the population of the state, is on the increase, which means a larger turn-over of LP merchandise and a greater diversity of music from which to choose.

Alaska also has players and composers of electronic music. Perhaps best known was the group "Gary Sloan and Clone", an ensemble of musicians who existed in the mid to late 70s. All of the members played electronic instruments, and Mr. Sloan specialized in a harmonica interfaced with a synthesizer, a really quite advanced unit at the time. There are of course many "closet" nuts around, myself included. Many of us own small recording studios or are band members. I suspect that in the future there will be more of these people about.

At this point in time I own a Kitten II synthesizer, Hohner string ensemble (which I traded for a 1973 Fender Mustang bass and some cash), and a Yamaha PS-2 keyboard -- one of those little wonders. I consider getting the string machine a real coup, as they are nearly impossible to find in Alaska. Most recently, it was used by the Beach Boys when they played at Anchorage's new sports arena in spring 1983.

As for the future of electronic music in Alaska, the picture looks good. I manage to keep current on things electronic by reading Polyphony magazine, a real beacon in the desert of electronic music in Alaska. I hope to form an association of synthesists in Alaska in the next year or two. In the meantime, I plug away at my home studio, waiting for my first polyphonic modular system to show up at my doorstep, or to win a keyboard in some contest. I would be interested in communicating with other synthesists; write me at 3809 Barbara Drive, Anchorage, AK 99503 (telephone 907-248-1294).



nationalists Respighi, Grieg, Sibelius, and Saint-Saens. To a large degree, the birth of the structureless "tone poem" is the beginning of New Age music.

Aging hippies may make up the bulk of the current crop, but they certainly don't have any claim to title. Listen for example to Peter Davison, who slips effort-

lessly from Faure's "Pavane" to the heart of the New Age. Synthesizers or no, there isn't much truly "new" in music.

Robert Carlberg  
Seattle, WA

#### VOICE/CASIO COMMENTS

In your May/August issue, George Western wrote to you for help with a couple of ideas. To respond to his first question, one idea would be use PAIA's envelope

follower/trigger module to control some of the synthesizer modules such as envelope generator, VCF, VCA, etc. The envelope follower/trigger will take a control voltage & trigger from a microphone. Another idea is rather similar to what Polyphony suggested: using a fuzz and volume pedal, followed by an octave box (to get voice into the pitch range required by the next effect), followed by an Electro-Harmonix "Bassballs" effect.

continued on page 32



# re-view

Weather Report **Procession** (Columbia 38427). This truly is a "pro session" of hand-picked musicians, immediately recognizable as Weather Report even though 3/5 of the group is new. As usual Zawinul carries most of the weight, and introduces several useful new synthesizer sounds. For fans, it's another fine chapter in an already epic book.

Nightcrawlers **Midwinter Daydream** (cassette). Group electronic improvisations which owe a lot to the German "Kosmische Musik" of the early '70s. Recorded live in one take, it shows the Nightcrawlers to be every bit the equal of Tangerine Dream, Popul Vuh, or Eberhard Schoener of that period. \$4 postpaid from Peter Gulch, 1493 Greenwood Avenue, Camden, NJ 08103.

Peter Davison **Star Gazer** (Avocado 103; cassette), **Forest** (Avocado 104; cassette), **Mountain** (Avocado 105; cassette). Drifting New Age meditation music. Along with mellow synthesizers, **Forest** includes harp, **Mountain** includes flute, sax, and some Oriental instruments, and **Star Gazer** includes everything plus piano and a string quartet. Davison's principle has always been (see also May/Jun '81, Sept/Oct '82) to combine the "New Age" concept with similar ideas from the past and other cultures. **Mountain** uses many Oriental motifs and develops some real anthemic passages. **Star Gazer** (like its predecessor **Glide**) is almost classical in places, recalling influences from Keith Jarrett to Maurice Ravel. A captivating body of work. \$9 each from Avocado Records, 1925 Euclid, Santa Monica, CA 90404.

Robert Rich **Sunyata** (cassette). I once fell asleep at a Terry Riley concert, and found it didn't

disagree at all with the mood of the music. Robert Rich apparently encourages audiences to doze off at his concerts, and this tape presents three of his electronic lullabies. He uses Prophet 5, bamboo flute, and taped natural sounds to form extended droning pieces which are as close to a musical womb as you could ask for. In the past I have criticized music for being "somnolent", but when it's intended this seems like the logical extension of the New Age/ambient/cosmic music movement. \$7 from Rich at PO Box 8891, Stanford, CA 94305.

K. Leimer **Land of Look Behind** (POL NMS .06), Savant **The Neo-Realist (At Risk)** (POL .15). The technique is this: all eight channels of Kerry's new 8-track are filled to the gills with unrelated stuff -- jangling percussion, synthesizer squawks, vocal loops, Prophet chords, bass, and drums. From this he mixes in and out (mostly in) to make a changing but undeveloping collage. Some people will probably like it, but it seems like a fairly tedious exercise to me. Palace of Lights, PO Box 4141, Seattle, WA 98104.

Joe Sample **The Hunter** (MCA 5397). A not-very-adventurous outing by the gentleman keyboardist of jazz. He sticks mostly to acoustic piano with only the occasional Prophet fill. His previous (reviewed May/June '81) would be a better bet.

The Crusaders **Royal Jam** (MCA 2-8017). I never bothered with this until a copy turned up in the local used record shop, since it's only a live rehash of some old tunes with the Royal Philharmonic and B. B. King as guests. In all, it hasn't been a vintage year for The Crusaders.

Matt Johnson **Burning Blue Soul** (4 A.D. CAD 113). The previous album to the The The E.P. reviewed in the last issue. Though not as catchy as the hit, it shows the same brilliant use of sound textures and recording techniques.

Kit Watkins **Frames of Mind** (Azimuth 1002). With the addition of Brad Allen's vocals, Kit takes a much more commercial stance than on his first solo album (Sept/Oct '82). And if there's any justice in the world, the track "My Telephone" will be a monster hit by the time this review comes out. It has all the hooks and has a lot of fun with telephone noises, and Kit's done a video of it too. Watkins is a Major Keyboard Artist and it's easy to forget that he plays almost all the instruments himself, records at home, and this is a private record. But prove it to yourself, send \$6.95 to PO Box 3495, Arlington, VA 22203.

Dagen Julty **Limited Occasions I** (cassette). Unselfconscious early material from a developing artist with lots of good ideas. You will hear guitar, voice, piano, bass, and drums, but you won't hear any "tunes" in the conventional sense. \$4 from Music Studio "A", 257 7th Avenue 3rd floor, New York, NY 10001.

Rudiger Lorenz **Invisible Voices** (Syncord 001). The first vinyl release by a dominant force in cassettes (see May/Aug '82, Nov/-Feb '83). Basically, it's similar to his tapes: a rhythmic foundation of electronic percussion, altered acoustic percussion, and/or gated synthesizer. Over this is a droning chord (or slow succession of chords) on, usually, a string-like synthesizer. Last, one or two other synthesizers play around with a simple melody and fill in assorted sound effects and noises. This is over-generalizing a lot, since no two tracks sound alike, but after about twenty tries it's the best I can do. He has the world's cleanest Dokorder too. \$10 postpaid all the way from Bingerstr. 6, D-6507 Ingelheim, West Germany.



# Editor's Notes



**M**IDI is here, and we all stand to benefit from it. MIDI is the tool whereby electronic instruments can interact with each other -- but there's no need for me to describe it here; just turn to Jim Wright's article on "What MIDI means for Musicians". I think you'll be as excited with MIDI's potential after reading this as I am. MIDI could easily be as important as the introduction of voltage control, and that's why Polyphony is right on top of this new development.

For more MIDI information, Stanley Junglieb from Sequential Circuits is back again (his last article was how to add a digital interface to the Pro-One) with an article describing the specifications from a detailed, technical standpoint.

Between these two articles, you'll have a pretty good idea of what MIDI is all about. And best of all, we're looking at some possible future articles which will make MIDI readily accessible for experimenters ...so stay tuned.

If you think you know what Vangelis is all about, think again. In this issue's interview, John Diliberto (who did the Klaus Shulze cover story for the May

issue of Keyboard) probes the cosmic and philosophical attitudes behind the public personality. It makes for fascinating reading -- even if you've read the many other Vangelis articles.

Finally, I'd like to say a few words of appreciation for those authors whose articles are sitting in Polyphony's files. As someone who writes a lot, I know what it's like to write something and wait -- and wait -- for it to appear in print, and sometimes, to never see it appear in print. (The Log LFO" I wrote for the February issue sat around since September '81 before being published). Of course, if you want an article back, that's fine with us and we understand. But our files represent one of Polyphony's greatest assets; when we need a particular type of article to balance out an issue, we just dig into the files, and what we want is bound to be there. So, please don't think that your work is unappreciated. It would be great if we could publish everything that came in as soon as it came in, but things just don't work that way. Nonetheless, thanks for your patience, and keep the faith.

Craig Anderton

## PLUG INTO



# Polyphony

## FOR ELECTRIFYING IDEAS!

- ( ) One year \$12 US/\$14 foreign (6 issues)
- ( ) Two years \$22 US/\$24 foreign

VISA/ Mastercharge accepted.

Card No. \_\_\_\_\_

Expiration date: \_\_\_\_\_

(signature) \_\_\_\_\_

Name: \_\_\_\_\_

Mail to: \_\_\_\_\_

Address: \_\_\_\_\_

POLYPHONY, P. O. Box 20305

City: \_\_\_\_\_ state: \_\_\_\_\_ zip: \_\_\_\_\_

Oklahoma city, OK 73116

**DON'T MISS AN ISSUE SUBSCRIBE TODAY!**

## Guitar Tuner

**\$39.95**



**Accurate**

**Easy to use**

**Unbelievably inexpensive**

... that's our new BANANA quartz guitar tuner. Thru-jacks let you tune electric guitars without unplugging. Acoustic guitars tune with built in condenser mic. Internal speaker produces by-ear tones if you want them.

Two easy to use tuning indicators -- a meter to indicate pitch deviations up to 1/2 semi-tone and LED go-no-go indicators, both with quartz accuracy.

Runs for months on a single AA penlight and one 9v. battery.

No. 9700A ..... only \$39.95 plus \$2.00 shipping.

Order yours today . . .

CHARGE TO VISA OR MC TOLL-FREE  
1-800-654-8657 9AM to 5PM CST MON-FRI

Ask for your free PAIA catalog.

Direct mail orders and inquiries to: Dept. 8Y

**PAIA Electronics, Inc.**

1020 W. Wilshire, Oklahoma City, OK 73116 (405)843-9626

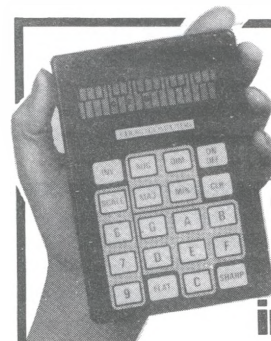

## Music Teacher in a Box?

To get ahead in music, you need to know music theory. PAIA's Chord Computer helps you understand both music and keyboards better by cramming the equivalent of pages and pages of music theory into a compact, calculator-style package.

The Chord Computer is easy to use. Simply select a chord letter, and the Chord Computer's LCD 31-key piano keyboard display will show which notes to play for the selected chord. Press another button to choose sharp, flat, major, minor, augmented, diminished, 6th, 7th or 9th chords -- including inversions. The Chord Computer can also display complete scales for all keys, or even transpose them at the touch of a button.

Serious about music? The Chord Computer could be the best investment you'll ever make. **only \$59.95** (plus \$2.50 postage/handling) **Order yours today . . .**

CHARGE TO VISA OR MC TOLL-FREE  
1-800-654-8657 9AM to 5PM CST MON-FRI

Ask for your free PAIA catalog.

Direct mail orders and inquiries to: Dept. 8Y

**PAIA Electronics, Inc.**

1020 W. Wilshire, Oklahoma City, OK 73116 - (405)843-9626



# What MIDI Means for Musicians

By: Jim Wright

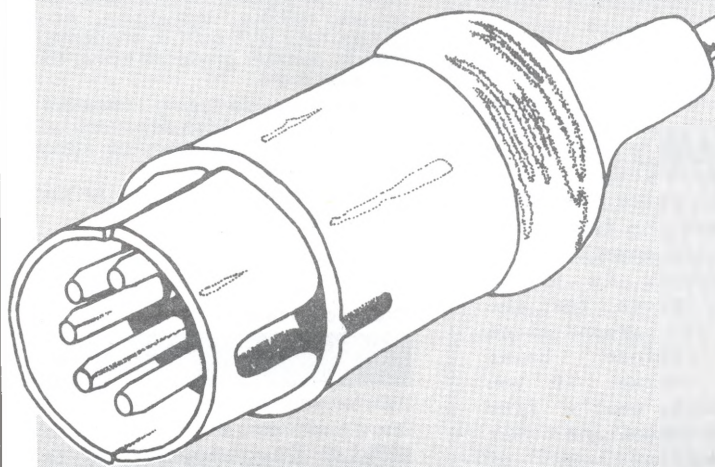

(Jim Wright is a Product Engineer for Unicord, where he helped develop the Korg Polysix, Mono/Poly, and subsequent products. He attended the Guitar Institute of Technology and received a B.A. in Music and Musical Technology from Hampshire college.)

MIDI (the Musical Instrument Digital Interface specification; see *Polyphony*, February 1983, pp 36-38) will have both immediate and long term effects for musicians. This article gives an overview of MIDI so that we can consider what MIDI can do for musicians.

**Basics.** The MIDI specification covers both hardware and software. The hardware portion covers a connector spec (5 pin DIN plug); interface spec (opto-isolated current loop, to prevent ground loops and avoid noise pickup); and transmission spec (serial, 31.25 kBaud -- the beginning of a new note, including velocity data, takes just under a millisecond to transmit).

The software portion is more involved. MIDI is essentially a specialized language for describing and controlling musical events in real time (in other words, as they occur). MIDI also includes a "channel" concept (more on this later) for organizing equipment resources.

**A software language.** MIDI provides "words" for describing (or requesting) musically related events. These "words" are short pieces of machine-language data; they provide a foundation upon which larger programs can be built, thus creating "friendly" ways for musicians to interact with their equipment.

The "words" used to describe or request a particular event are identical. The only difference is whether a given unit is sending or receiving that "word". If you play middle C on a keyboard, the synthesizer will sound the note, and also send a short "phrase" through the MIDI port that means "Note Event: ON, Pitch: MIDDLE C, Velocity: (ATTACK VEL. VALUE)". Release the note, and another phrase will be transmitted that means "Note Event: OFF, Pitch: MIDDLE C, Velocity: (RELEASE VEL. VALUE)". If a sequencer records this pair of phrases, to play back that note later all the sequencer must do is transmit the very same pair of phrases to the synthesizer, at the appropriate times. The synthesizer will play Middle C, even though no key is pressed.

We'll describe the MIDI vocabulary shortly, but first, we need to understand what "channels" are and how they are used.

**"Channels" for directing musical traffic.** In addition to a basic set of "words", MIDI provides a way to identify particular "talkers" and "listeners" on a single MIDI "party line". The channel concept allows a home computer (or similar device) to use only one MIDI interface link to communicate with:

- Several simple instruments, of similar or different types (mono or poly synths, rhythm units, etc.)
- A complex instrument with split/doubling capability or separately programmable voices.
- Any combination of the above (up to 16 channels on one MIDI link).



FIG. 1

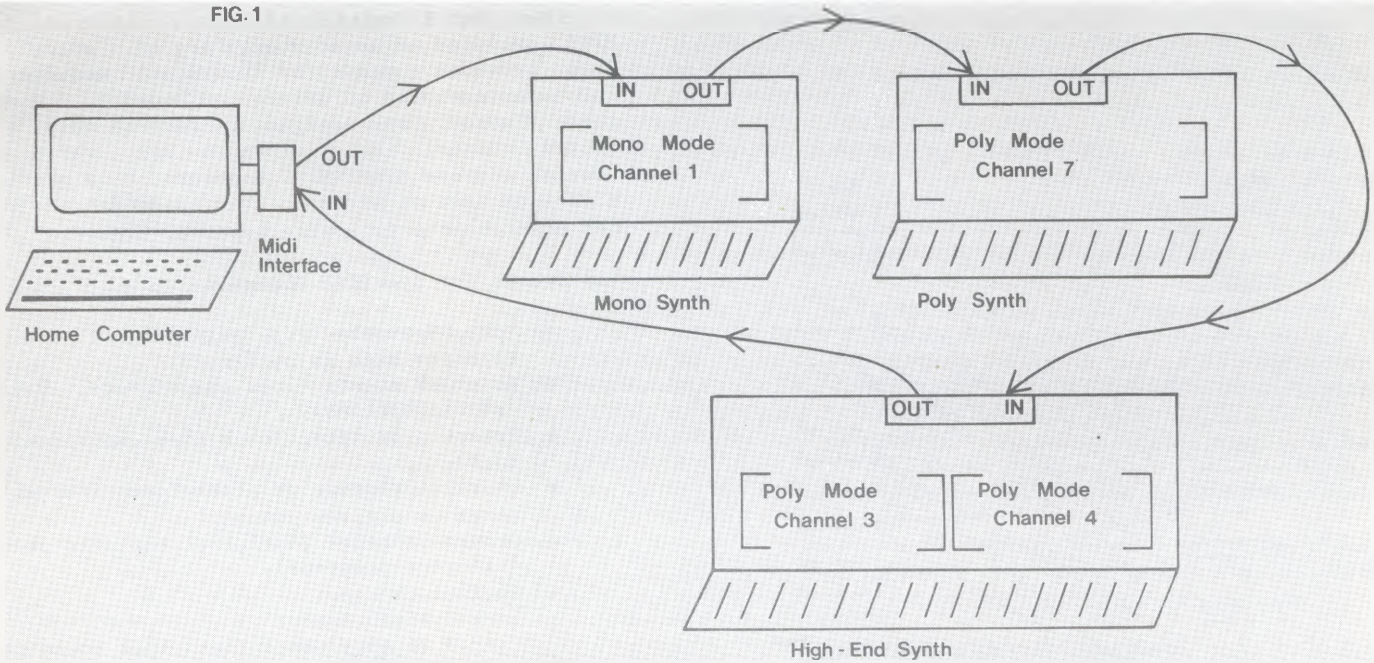

Different units are connected on a single MIDI link by "daisy chaining" cables between each unit and the next (see figure 1).

Software channels allow information to be sent between selected units on a single MIDI link, without confusing other units connected to the same link. However, for this approach to work, MIDI-compatible equipment must be able to send and receive information on one or more "channels". A synthesizer like the Korg Polysix or Prophet 5 would need only one channel to handle musical information travelling between a home computer and the multiple synthesizer voices. This is because all voices are programmed for the same sound, and it doesn't matter much which voice is assigned a given note. Synthesizers such as the Oberheim OB-8 and Prophet T-8 would require at least two channels in "split" or "double" configurations. With instruments like these, two different programmed sounds (and related sets of voice circuitry) are involved -- either side by side in "split" mode, or one on top of the other in "double" mode. Since the Chroma provides sepa-

rate control over each voice, it could conceivably require 16 different channels!

Note, however, that a "channel" is NOT the same thing as a single voice or set of synthesizer voices: it is not a physical "thing", but a method of handling information. You can think of a channel as a "software pipe" (figure 2) which directs musical event information to a desired destination.

**Modes for changing channel behavior.** Since these channels are software, not hardware, they can be redefined easily. MIDI provides three different modes for using channels, in order to provide the most flexibility. These are:

- **OMNI mode** (figure 3). In this mode, a synthesizer will respond to "words" coming in on ANY channel. This is like a studio piano player sight-reading an orchestral score -- he plays EVERYTHING, from solo flute parts to ensemble parts (assuming he has enough "fingers", i.e. synthesizer voices). You get this basic MIDI mode when you turn on the power,

FIG 2

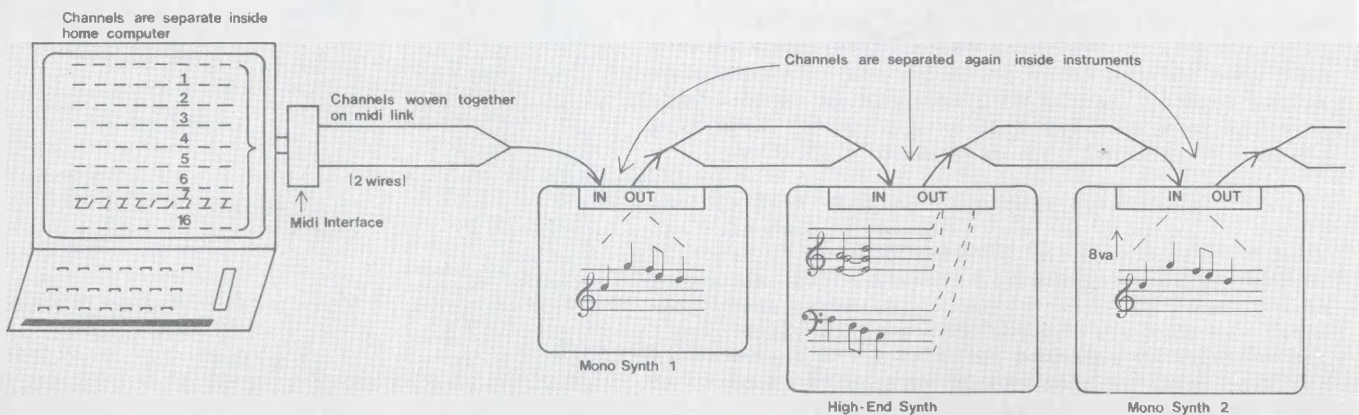
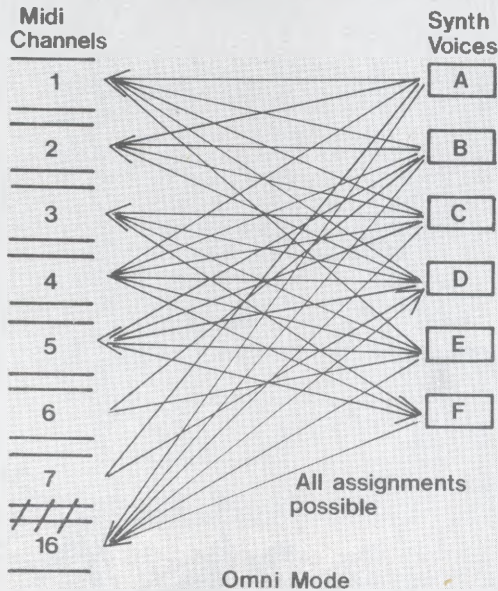



FIG.3



so that it doesn't matter if channel IDs are assigned correctly -- notes will still be played. The other two modes must be specifically requested.

• POLY mode (see figure 4). In this mode, a synthesizer (or part of a multi-channel synth) will respond only to "words" received on its assigned channel. Information sent on other channels will be ignored. It's important to note that "words" sent on a POLY mode channel can describe chords or polyphonic lines as well as single notes. Different instruments (or sections of the same one) can be assigned to different channels. This is like a piano player, guitarist, and sax player all reading from the same score -- the separate parts are printed on different staves (channels), so the musicians can keep their lines coordinated but separate.

• MONO mode (see figure 5). While similar to POLY mode, only single note lines can be sent to a given channel. Two other major differences between MONO mode and the other two modes are: 1) MONO mode allows legato, and 2) MONO mode assigns note events directly to a specific synthesizer voice, bypassing the normal internal note assignment algorithm.

To keep things simple, I've only used synthesizers as examples so far. However, channels can also direct information to other equipment, such as rhythm units, programmable effects units, automated mixes, and so forth. The logical separation provided by channels ensures that a synthesizer won't get confused by commands intended for a rhythm unit, and vice-versa -- even though both units connect to the same set of wires (see figure 6).

Now that I know how to say it, what can I say? MIDI includes a basic vocabulary of "words", and also provides a means for individual manufacturers (or experimenters) to define new "words". Some of these "words" are designed to address only a selected channel (any 1 of up to 16), while other "words" address EVERYTHING connected to a particular MIDI link (set of wires). The basic set of "words" can describe the following types of events:

(A) Events for Specific Channels

- Note ON events (i.e. beginning of note. Velocity data is optional).
- Note OFF events (i.e. end of note. Velocity data is optional).
- Pressure or After Touch (for individual notes).
- Overall Pressure or After Touch (for all notes in a given channel).
- Program changes (different channels can have different programs).
- Control changes:
  - 1 Pitch Bender
  - 3 Primary Controllers (not bound to specific parameters)
  - 28 Secondary Controllers (undefined) (Note: The above controllers are continuous controllers such as pots or sliders. They can be either low resolution (128 different values) or high resolution (16,000 different values).
  - 32 ON/OFF switches
  - 29 "Open" (completely undefined) locations for future use
  - Channel MODE selection (Omni, Poly, or Mono). Also serves as "all notes off" command.

FIG.4

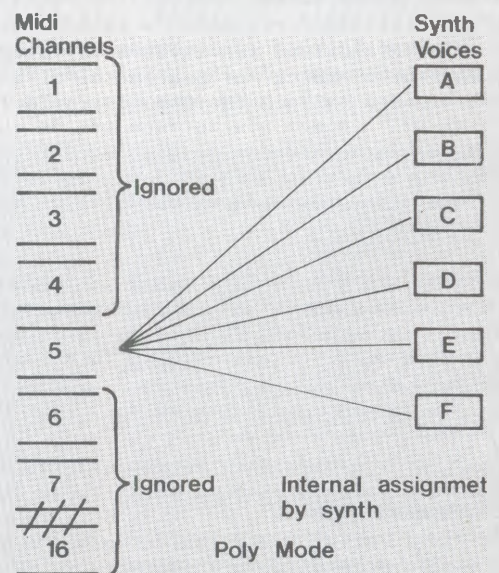



(C) System Real Time Events (for all Channels)

- System Reset Code -- sets all equipment to its initial condition (i.e. just after power is turned on).
- Timing-Clock-in-Play -- provides a clock at 24 steps per beat while the transmitter is in Play mode. (Only one master clock should be used throughout a complete system.)
- Measure End -- used instead of Timing-Clock-in-Play at the end of each measure.
- Timing-Clock-in-Stop -- used instead of Timing-Clock-in-Play when the system is NOT playing. This is needed to keep internal circuitry synchronized while the system is stopped, or for fadeouts.
- Start-From-1st-Measure -- sent just before the first Timing-Clock-in-Play timing pulse, when the PLAY button on the master unit is pressed.
- Continue-Start -- used to resume a musical passage from where it was stopped, without restarting from the first measure.

(D) System Exclusive Information

- Used to add new functions (like programmed data transfer) which are specific to particular manufacturers or products.

NOTE 1: All of the Real Time Codes have priority over Channel or System Common "words". This means that timing information may be "woven" into long passages of other data without causing confusion. This prevents Note Event data and Timing data happening at the same time (for example) from either sounding wrong notes or throwing the system out of sync.

NOTE 2: The MIDI specification has provision for the creation of new "words" as the need develops. These words can be either general purpose (such as words for automatic channel ID assignment), or specific to particular manufacturers (such as words for dumping or loading program data).

FIG.5

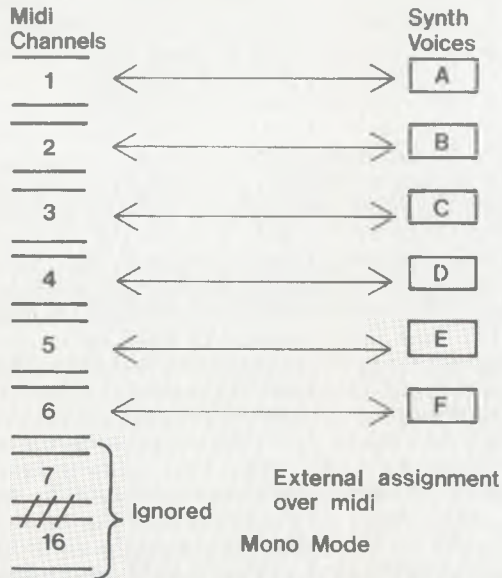

(B) System Common Events (for all Channels)

- Current measure number.
- Song Select (command) -- selects one of 128 different songs, by number.
- Tune Request -- asks a connected unit (such as an expander module) to go through an internal "auto-tune" routine.
- End of Block -- used only to terminate System Exclusive information (special function codes or information for products of specific manufacturers).

FIG.6

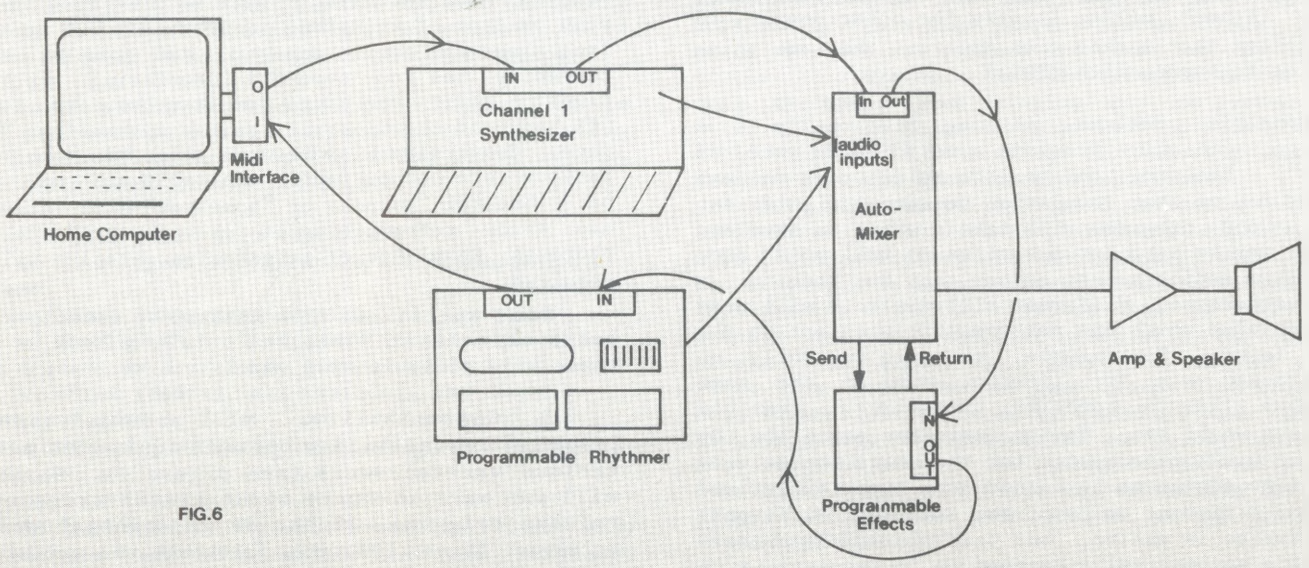



Now that we've established a good overall understanding of what MIDI is, we can go on to consider its broad effects, some possible problems, and specific effects.

**Broad effects of MIDI.** While MIDI will initially make it much easier to interconnect equipment, it is probably the software part of MIDI which will have the greatest impact over the next few years. Remember, MIDI is really a specialized language for describing and controlling musical events. Since it is receiving broad commercial support, and only requires relatively low-cost equipment, the character of music-making may change in very interesting ways as people learn to speak the MIDI language fluently. For example, MIDI allows musicians -- not just manufacturers -- to construct and modify new musical instruments which have a large software component. Exactly how this is done is beyond the scope of this article, but the major points are that user-changeable software will be the foundation of such instruments, and that MIDI accesses the "insides" of equipment without having to open it up. At last -- something you can modify without breaking the warranty!

The modifiable nature of software means that software-based instruments can be easily customized. The modular nature of MIDI will make it economical and simple to expand a "music system". These two factors will create instruments which actively interact with musicians, or provide substantial help while composing or working in the studio.

Of course, most of these ideas are already familiar to Polyphony readers. Why does MIDI put all of this suddenly within reach? Because it provides a well thought-out, clearly structured, reasonably efficient and low cost means of handling most of the problems involved. This is good for experimenters as well as manufacturers; trying out new ways to use computers with synthesizers is much easier when the basic groundwork is already done.

Just as important, MIDI will be supported by many (if not all) synthesizer/electronic music manufacturers. This will eventually make MIDI compatible equipment commonplace, and also encourage a lot of smaller companies to make software and peripherals that will work with MIDI equipment. (Many will remember how Apple Computer became successful partly through making it easy for other people to make things that worked with Apples; the same thing is going to happen with MIDI.)

**Possible problems.** Although MIDI really is a language, it only provides a very basic set of "words". Building things like multi-track sequencers on top of that foundation requires significant work. Good programs will take a while to develop, and it may be hard for musicians to tell good programs from mediocre ones before they buy them.

Furthermore, different MIDI dialects will probably develop which are not compatible except on the basic level. For example, there is currently no standardized way for different units on the same MIDI bus line to identify themselves. Possible solutions would be: Having musicians punch IDs by hand into a home computer (or the units themselves) every time equipment is turned on; providing fixed IDs for different units of the same (or different) types (which is easier, but less flexible); or having units automatically respond to ID requests, with

assignments made by a home computer when the system is powered up. Since each method has its advantages and disadvantages, different manufacturers may use different methods. There are several other unresolved points which may produce conflicting implementations in the future. (Editor's note: however, MIDI will hopefully be a living specification, which implies that those manufacturers who support MIDI will periodically get together to introduce new features or resolve potential conflicts).

Another problem would be units that don't implement MIDI completely. The MIDI specification can handle things like panel control changes, timing codes, song and measure IDs, and velocity and pressure data -- but that doesn't mean that all "MIDI-compatible" products will handle all of these functions, meaning that certain marginal but very useful features may not be included in some products. For example, the Prophet 600 and Prophet 5 (with MIDI retrofit) can only operate in OMNI mode (receiving and transmitting data on all channels, regardless of channel ID). This limits flexibility when several units connect to the same MIDI line, because in OMNI mode you can't address them separately. However, the limitation to OMNI mode may, in some cases, make it easier for musicians to connect units together, since they won't have to worry about matching the Channel IDs of different instruments. (On the other hand, the Prophet T-8 provides OMNI mode when turned on to minimize problems, but can provide POLY and MONO modes on request.)

Other features that are not absolutely required for MIDI compatibility include the ability to transmit and receive control changes, and the ability to send keyboard data directly to a computer (bypassing onboard synthesis circuitry) in order to produce computer-controlled arpeggiation or other note processing. While many musicians will not miss these "fine points", some will probably find that it's the "marginal" features that make a big difference in how much they can do with MIDI. Those who need a more complete set of features may want to wait for second generation MIDI products.

A final problem area involves trying to use MIDI-compatible equipment with older gear. Although adapters may become available in some cases, often the basic design of a product is simply incompatible with a MIDI retrofit. This is clearly a problem when no type of interface is provided, but an interface alone may not be enough. For example, Roland currently has four separate interfacing specifications: MIDI, the Micro Composer bus, the Juno 60 DCB bus, and the GR-series guitar synthesizer interface. Conversion kits between all of these specifications are not currently available and may never be. General purpose or "homebrew" MIDI interfaces may allow retrofitting of earlier products, but thorough knowledge of interfacing details will be required.

**Some specifics.** Now that we've considered the broad effects of MIDI, let's take a look at what these wild claims really mean.

**1. Compatibility.** MIDI provides low-cost "plug in" compatibility between equipment made by various manufacturers (see figure 7). No longer will you have to worry about switch triggers vs. voltage triggers, linear or exponential control voltages, 5V vs. 10V, etc. (although you may have to watch out for occasional proprietary MIDI dialects).

FIG.7

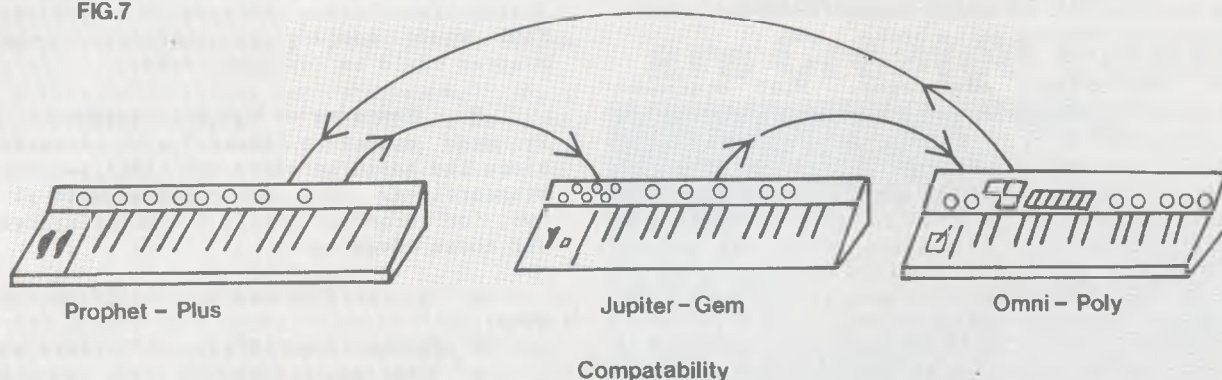

Note that not all manufacturers have agreed to support MIDI. Some manufacturers have already developed proprietary interfaces, while others make very high-end equipment that needs more speed or flexibility than MIDI provides. However, the advantages of a common specification are so overwhelming that most manufacturers will probably comply simply to help advance the state of the art; the list so far includes Kawai, Korg, Moog, Oberheim, Octave-Plateau, Roland, Sequential Circuits, and Yamaha.

**2. Fewer hardware problems.** MIDI also prevents ground loops which could cause hum problems, and works fast enough to avoid noticeable timing delays between when you play a note and when it sounds. The hardware interface is sufficiently inexpensive to include in almost any microcomputer-based product. Neither the RS-232 standard nor any other existing hardware standard could provide all of these features, which is why a new hardware specification was needed.

**3. Flexibility.** We can expect MIDI-compatible synthesizers, rhythm units, sequencers, mixing consoles, home computer interfaces, and effects systems within the next year or so, all of which will be easily connectable. In this new type of "modular" system, individual "modules" will be complete units including many functions and local intelligence.

**4. New computer and software "tools".** These will provide assistance in such areas as creating and transcribing music or improving music skills. The most obvious possibilities are:

- Multi-track poly sequencers
- Intelligent arpeggiators and accompaniment systems.
- Music transcription aids
- "Toolkits" for composers (the possibilities here deserve an article by themselves!)
- Sight reading, ear training, and music theory tutorial
- Aids for creating, modifying, and analyzing sounds.

As time passes, it will become relatively easy to add new features and modify old ones, although the quality of available software will have a great

impact on this. Hopefully, general purpose, "user-friendly" music languages built "on top of" MIDI will be developed. Such languages would allow musician to create software tools by themselves which reflect their own concepts and preferences for organizing sounds into art.

**5. Coping with obsolescence.** While it will never be possible to "cure" the problem of obsolescence, MIDI can make future shock less painful because you will be able to connect the latest device directly to equipment you already own. MIDI is a good enough specification that it shouldn't become obsolete for at least a few years.

In the meantime, you'll be able to upgrade your equipment gradually, a piece at a time. This will be much easier on your wallet, and also means that you will be able to get the most current technology every time you buy something. With MIDI as the connecting link, equipment made three or four years apart, with vastly different capabilities, should still be able to work together smoothly.

**6. Sharing of resources.** MIDI also makes it possible to do more with less. Expensive items such as touch-sensitive keyboards can now be shared throughout a system -- you will no longer need separate keyboards for each synthesizer. Another possibility is a MIDI Master System Clock, which would replace the various sequencer and rhythm unit clocks in a system. Besides offering easier control, the money saved by using only one system clock will allow you to get a unit that's directly compatible with SMPTE time code, for industry standard sync-to-tape and autolocate capabilities.

Both high-capability remote keyboards (with no synthesizer voices) and sophisticated expander modules (voice circuitry with no keyboard) will surely be developed as manufacturers catch on to the full implications of MIDI. Systems that are fully responsive to your specific needs will be easy to create (see figure 8). Imagine a custom system where you could use the same floppy disk drive to hold several different music synthesis and composition programs, the percussion and melody scores for your current piece, the automated mixdown for your last piece, and an article you're writing for Polyphony. You won't even need to switch wires to change applications!

\*As soon as off-the-shelf MIDI interfaces for



home computers and experimenters are developed, resource sharing will become a very effective way to create high-capability music composition and performance systems without going broke.

**7. Performance advantages.** MIDI equipment will generally be more compact and easier to set up than older equipment. Because all information is digitally combined and transmitted over single cables in a MIDI system, loose wires are far less of a problem. Furthermore, you will almost never need to change wires once they're set up, since all switching functions are again handled digitally. The "software tools" discussed elsewhere also have major implications for live performance.

**8. Synchro-sonic capabilities.** A 24 pulses-per-quarter note clock pulse can be woven into the stream of MIDI data. Since this stream of timing goes everywhere in a MIDI-based system, everything can potentially be synchronized together. A single SMPTE-compatible Master Clock module would be an ideal addition to a basic MIDI system.

Programmable clock decoding circuitry could be built into advanced instruments to allow all sorts of processes to be linked synchro-sonically (arpeggiators, EGs and LFOs for synthesizers, rhythm unit and sequencer clocks, etc.). The benefits of synchro-sonic capabilities are fully discussed in a recent two-part article by Craig Anderton (*Keyboard* magazine, 1/83 and 2/83). His Master Synchronizer module was designed before MIDI was adopted, but nonetheless uses the MIDI clock specification -- so it could be used with MIDI equipment that doesn't have built in clock dividers but does have the

necessary clock pulse inputs. Unfortunately, the Master Synchronizer cannot be directly connected to a MIDI link, since the form of digital data used by MIDI would confuse it (hopefully some sort of adapter could be designed -- Ed.).

**9. Homebrew or D.I.Y. equipment.** MIDI makes it much easier to "tinker" with complex systems, since the basic hardware and basic software has been standardized. You no longer have to invent your own, or reconcile widely different systems. Consider these advantages:

- A solid foundation -- 50% of the work is done.
- Assure compatibility with other equipment.
- Easy modifications. You can use MIDI (at least on some units) to change the behavior of the instrument. To do this, a unit must allow control parameters to be changed over MIDI, and should ideally have separate "channels" and control settings for each voice (or else be operated in Mono/Unison mode). If you don't have enough envelope generators -- just add some! Software envelope generators can be created in a home computer and then coupled directly to desired parameters in a synthesizer. MIDI can change parameters a thousand times per second, which is more than fast enough for most purposes.
- Versatile software tools can be created with a MIDI interface card and a home computer (such as the VIC 20, Commodore 64, or Radio Shack Color Computer). Polyphony will doubtless be publishing articles on what you can do with this type of equipment.

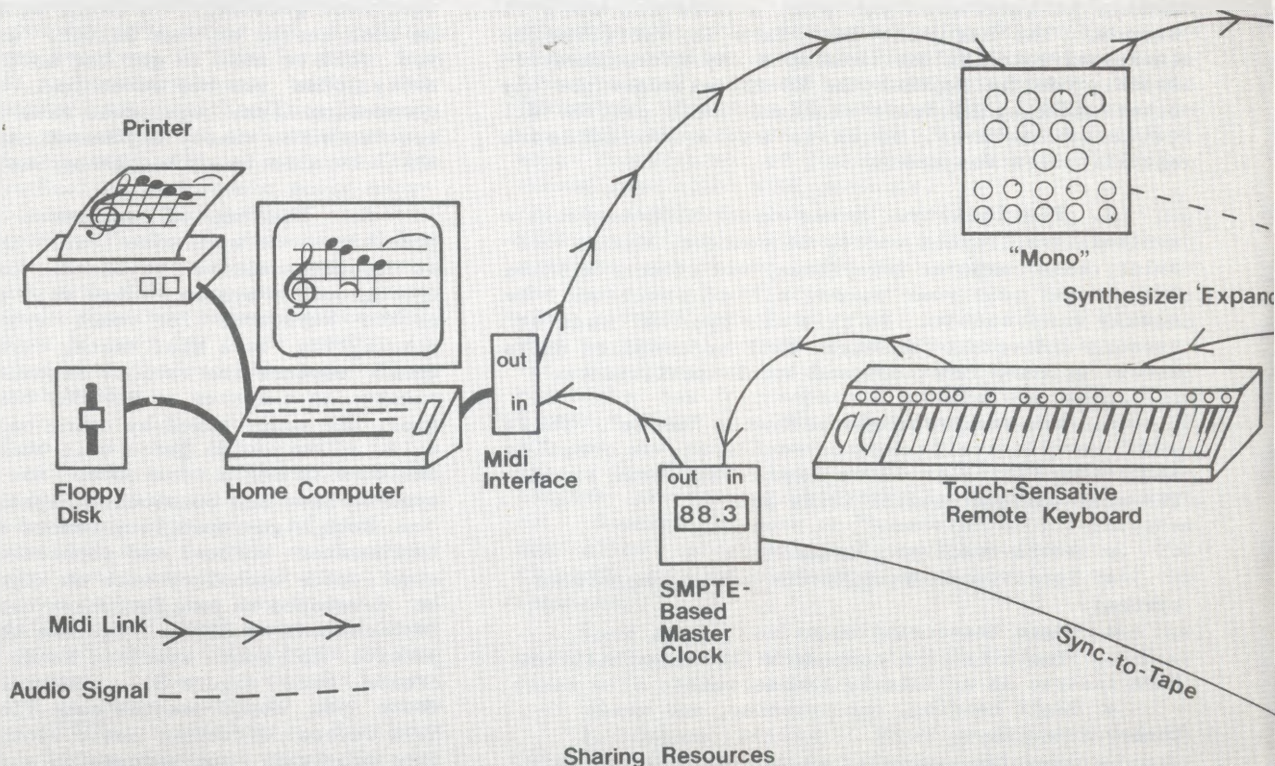

FIG.8



• Homebrew and commercial controllers and synthesis equipment can be readily combined. All that's needed to connect do-it-yourself designs is a general purpose MIDI interface, which should become available soon.

• A MIDI retrofit (or even programmer) could be added to older keyboards. It shouldn't be long before cost-effective, music-oriented controller boards are available which are relatively easy for technically-aware musicians to use.

\* \* \* \* \*

I hope this article has given you a sense of what MID has opened up for all of us. MIDI is just as much of a step forward as the invention of voltage control or programmable synthesizers. The fact that it was developed through joint action of several manufacturers is also a landmark, and a very positive sign for the future.

MIDI will not only provide new and powerful equipment for making music, but, in giving us the ability to customize instruments ourselves, it will help personalize electronically produced music in ways that simply haven't been possible before. In turn, this will fundamentally change and enlarge the shape of music. The possibilities are truly exciting -- I can't think of a better time for musicians to be alive!

# Not all Wireless Microphones are Created Equal



## This One Is A Telex

Recommendations by performers, as well as engineers, have made Telex the fastest growing wireless mic system in the industry.

Performers tell us they prefer Telex wireless mics because of the rich, full-bodied sound. And because the mics feel and look like conventional microphones.

To quote performers:...the Telex wireless mic sounds superior to any I've used for vocals—wired or wireless...

...the freedom it gave our group sold me on the concept, and the sound sold me on Telex...

Audio and broadcast engineers stated that they prefer Telex because with just the addition of a second antenna, they have the most reliable diversity\* wireless mic receiver available, indoors or out. And because the compander circuitry provides dynamic range from a whisper to full fortissimo.

To quote engineers:...the Telex wireless is the best we've tested, and we've checked them all...

...from a quarter mile, the signal was still crisp and clear...  
...for the money Telex outperformed all others we tried...

When you're ready for wireless mics, Telex offers you a choice of three VHF frequency groups, hand held or belt-pack transmitters, dynamic or electret microphones and a host of accessories. Compare our specs against any others, and by all means, compare the price. We're quite certain you'll also prefer Telex. Made in USA. Please write for full details.

\*US Patent No. 4293955. Other patents applied for

Quality Products for the Audio Professional



# TELEX®

TELEX COMMUNICATIONS, INC.

9600 Aldrich Ave. So., Minneapolis, MN 55420 U.S.A.  
Furne: Le Bonacarte—Office 711, Centre Affaires Paris-Nord 93153 Le Blanc-Mesnil, France

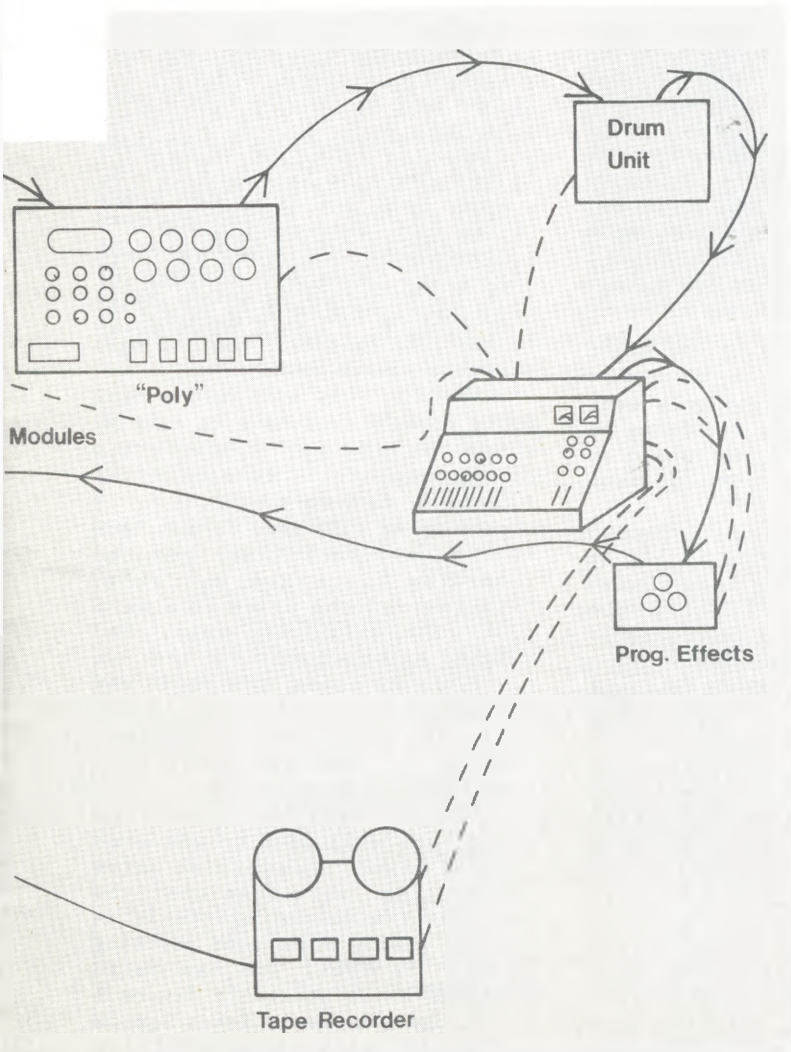

Polyphony





# Creative Recording

## On a Shoestring Budget

By: Delton Horn

Creative recording is a fascinating and dynamic hobby. Maybe you want to make your own "live" tapes, and edit them into a professional sounding package; perhaps you play an instrument or two and want to record your own duets (or trios, or quartets, or whatever); or maybe you just want to experiment, and have some fun with the recording medium.

While a number of books and articles have been published on the subject of recording, and many of them are excellent, they almost universally assume you have a few thousand dollars to spend on your hobby. After all, two or more reel-to-reel decks, mixer, microphones, plus accessories such as equalizers, noise reduction, echo units, and so on can quickly add up to a hefty investment. That's fine if you're really serious about recording, but if your interest is on the hobbyist level, you might not want to risk that

much money on something you might decide isn't for you in a few months. Or perhaps you only want to dabble in creative recording on a now-and-then basis; it would be wasteful to invest a lot of cash in a casual hobby.

So what can you do? Should you just shrug and give it all up to turn to something less financially demanding, like bottle cutting or collecting beer cans?

Not necessarily. There are a few ways to cheat a bit and get that bill down to a manageable level. Of course, the end results may be a little shy of professional quality, but you can still have a lot of fun exploring the intricacies of creative recording on a budget. And, with a little ingenuity, you can create some very nice recordings indeed.

You will first need a fairly good (preferably three-head) open reel tape deck. Yes, reel-to-reel decks do cost a bit, but with some careful shopping you should be

able to find one for about \$500. I started out with a Realistic 999B; this was a low-priced deck with reasonable quality for the price. This particular unit has been discontinued for a few years now, but I want to emphasize that a budget model is fine. Used machines might cost even less. However, a standard cassette deck will not do, at least not as your primary deck. Editing cassettes is next to impossible, and you are severely limited in the type of special effects you can create.

My Realistic deck has sound-on-sound capabilities, which allow for some simple mono mixing. After playing around with this feature for a while, I realized its limitations can outweigh its advantages. If the machine you choose happens to come equipped this way, fine -- it might come in handy now and then. But don't make it a deciding factor in selecting a tape deck. You can easily do the same thing with external connections anyway.

**Getting started: the dual-deck approach.** There are two basic routes you can take for multi-channel work (or for the greatest versatility, combine the two). The first possibility is more expensive, but a lot easier: simply get two decks. With two decks you record the first track (part) on deck 1 (which becomes the playback deck), then play it back into the right channel of deck 2 (the recording deck), while also putting new live material on to the left channel. You now have a simple stereo duet.

Notice that one of the tape decks doesn't even have to record, since the tape may be physically moved from deck 1 to deck 2 for playback and re-recording. I picked up an old, used German deck that played back fine, but the recording circuitry was shot. This lowered the price to a mere \$35! The thing was ugly, and weighed a ton, but it did the job.

In some cases, you could use a cassette deck as the second deck, but it will be to your advantage to have two decks that take the same kind of tape.

If you want more than two parts, you will need to add some kind of mixer. Commercial units can cost you more than what you paid for the recording itself -- but you really don't need anything fancy. In fact, you can build your own mixer yourself; figure 1 shows the schematic for a "quick and dirty" mixer that would be



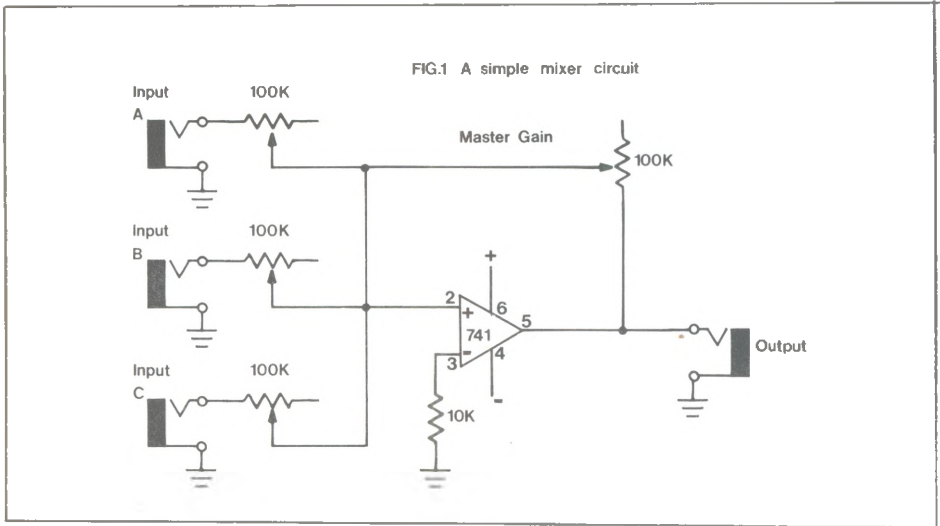

enough to get you started. For stereo, you would need a mixer for each channel.

With a mixer between the playback and recording deck, you can theoretically add as many parts as you like. There is a practical limitation, however. Each time you re-record onto another generation of tape, you inevitably add more hiss and distortion, until eventually the signal becomes totally unuseable. Experimentation is the only way to determine the limits of your particular setup. This will rarely be a significant problem, unless you're trying to get very fancy.

**Getting started: the multi-sync approach.** The second method for creative recording, using multi-sync, is practical only with three-head decks. Some of the

better recorders have this feature built-in, but it's not hard to add it add it yourself -- you just need to install a few switches. But, I would advise you not to try this while your deck is still under warranty. Wait. Any kind of modification like this would completely invalidate any warranty policy I've ever come across.

Basically, multi-sync simply involves using the record head as a monitoring playback head. All you need to do is add a 4PDT switch, as shown in figure 2. Now, after recording your original signal on the right channel, you can put that channel into the sync mode while recording new material onto the left channel. Once again, you end up with a two-part piece in stereo. To get more than two parts you still need to go

through the dual recorder/mixer setup described earlier. But now, you're using fewer generations of tape, so you can add more parts with less overall noise build-up.

Record part A on the right channel of the sync-capable recorder. Add part B on the left channel. Then play the tape back on the other recorder, and mix it down to one channel along with a new part C, recording the results into the right channel of the sync recorder. Now use the sync function to add part D onto the left channel, and start all over again.

Of course, you can alter this sequence as needed to get a better sounding stereo mix. In this simple example, all of the parts would end up in the right channel, with a the single exception of the last part recorded on the left channel. Naturally, a third recorder would greatly increase your studio's versatility, but it adds to the expense (see figure 3).

There's another slight modification you can make on your deck while you have it open to add the sync switches. If you can switch out the erase head, you can add more parts to a single generation of tape (see figure 4). With this arrangement, you record the first two parts as described earlier. Then shut off the right channel sync and erase head, and switch on the left channel sync. You can now record a third part without erasing the first. Note, however, that if you make any mistakes you will have to re-do both parts one and three.

There's a limit to how many times you can pull this trick on a single generation of tape. After about the third pass on a single channel, the sound will start to get a bit muddy.

If all this is still too complex for you, you can still do mono mixing (bouncing) on a single stereo, three-head tape deck. For example, you would record part A on the right channel. You would then play back part A, along with new part B, through a mixer and record the results on the left channel (see figure 5). Next you would repeat the process, playing back the left channel with a new part into the right channel. You can record three of four parts without significant degradation of the sound.

\* \* \* \* \*

These tricks will give you a versatile, small scale recording

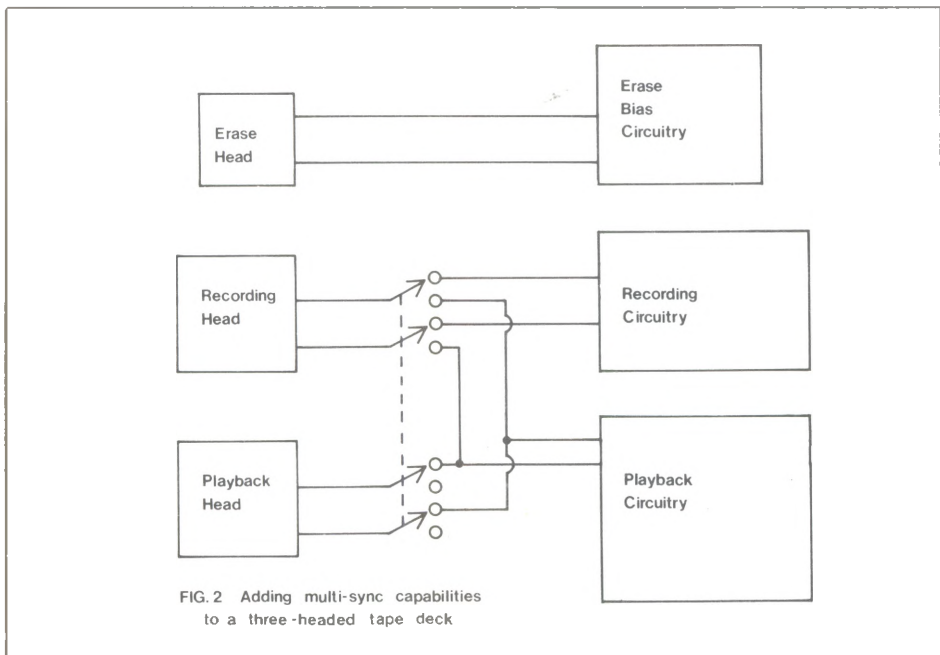
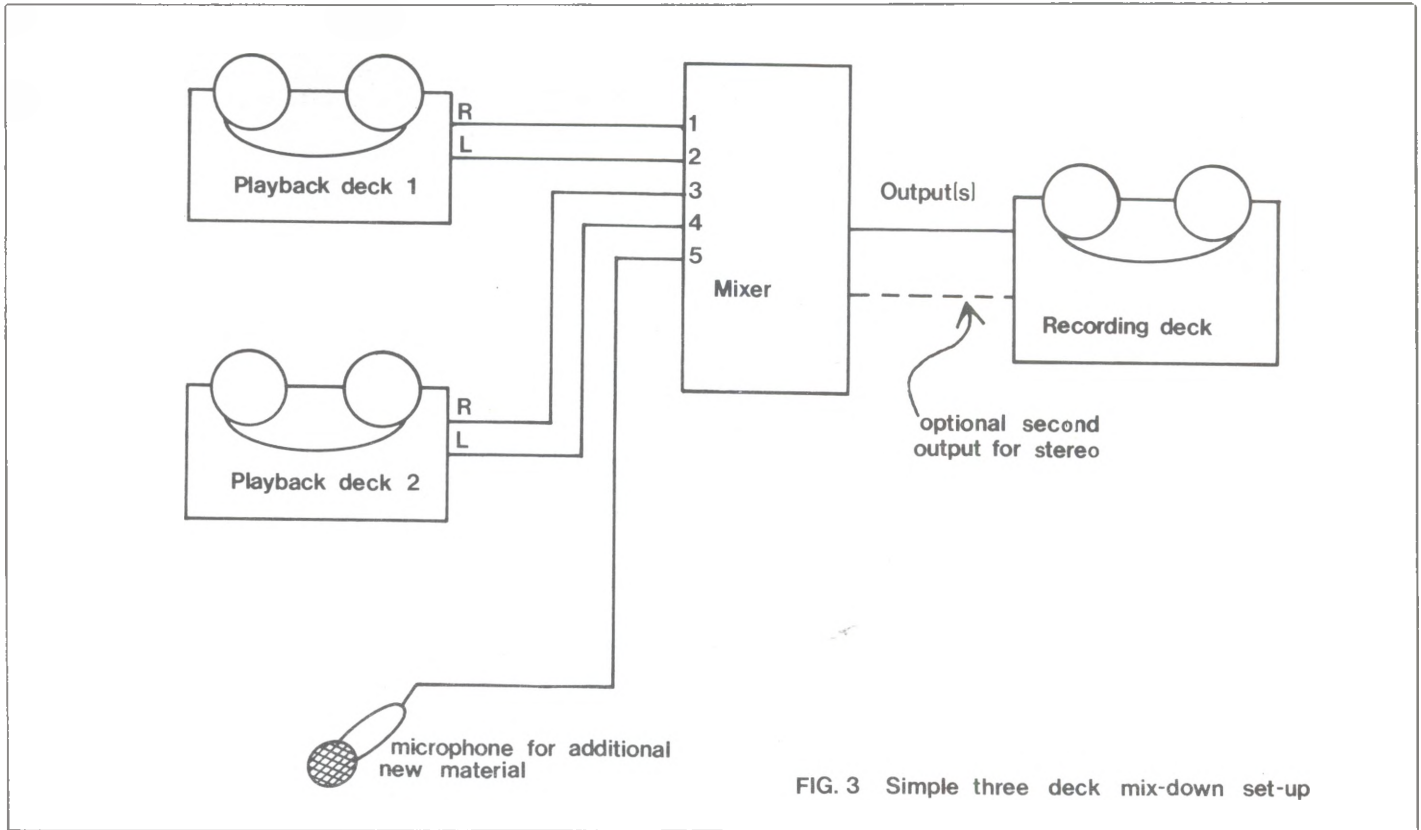

FIG.2 Adding multi-sync capabilities to a three-headed tape deck





studio on a relatively small budget. No one claims you'll get professional quality results this way, but you can produce some very good tapes, and enjoy a fascinating hobby without going into debt. It is also a nice way for you to get in plenty of practice before sinking some big bucks into a semi-pro setup, if that is your eventual goal.

(Delton Horn has written Electronic Music Synthesizers and The Beginner's Book of Electronic Music, both published by TAB Books.)

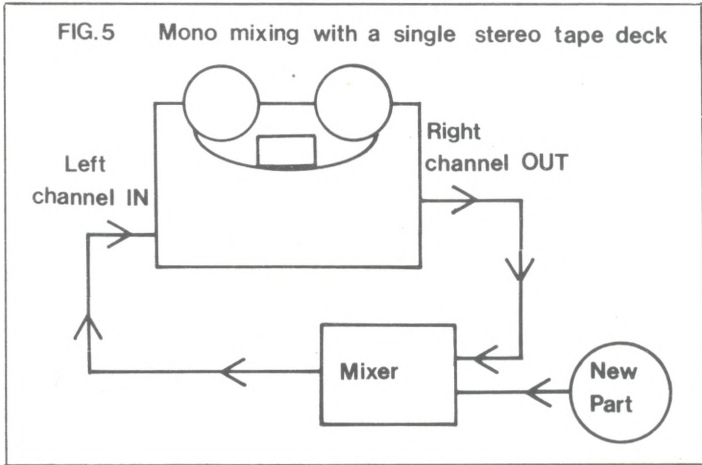
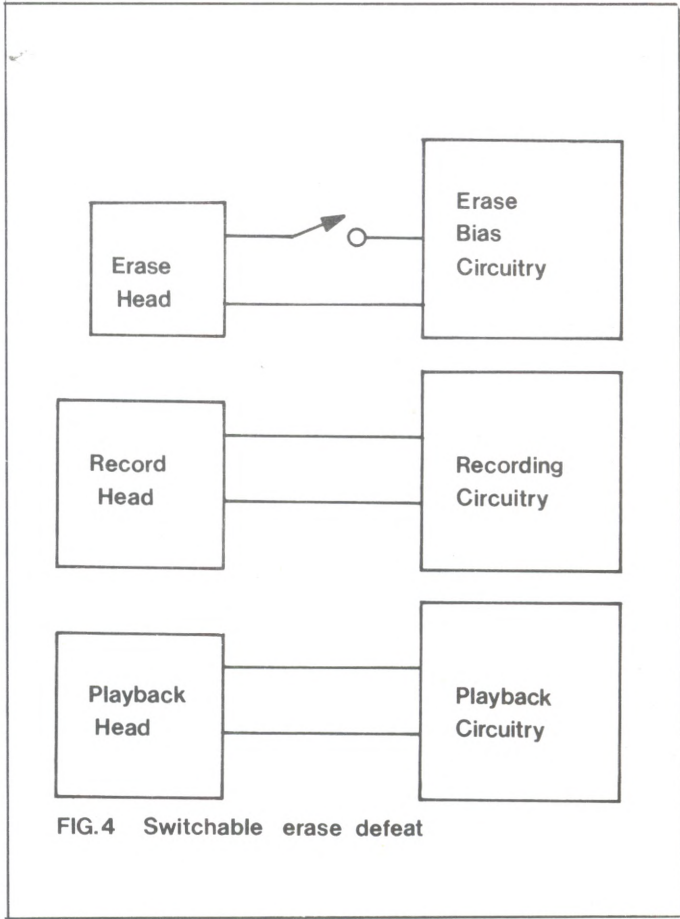



# An Electronic Switch for Musicians

By: David DiFrancesco

Here's a simple switching circuit which uses a minimum of parts, draws 0.5 mA with the LED off and 2 mA with the LED on, and can be operated at voltages up to 15 Volts (after that point, the CD4007 will blow).

In figure 1, inverters IC1A and IC1B (made up of part of a CD4007) change states when the momentary action in/out switch is pressed. The MOS-FET shown (included in the CD4007) is a P-channel type, so its impedance drops when the switch closes; this

changes the state of the two inverters, while capacitor C3 recharges through R13 to prepare for the next switch closure. R11, D1, C1 (and R12, D2, and C2) form a filter to de-glitch the switching FETs. R3, R4, and C8 for a bias network for the switching FETs. The 2N5089 may be just about any NPN transistor. The two resistors driving its base form a battery condition indicator, so when the battery drops below about 6 Volts, the LED dims.

The two J-FETs may be almost

any N-channel type, but the J-113 has a very low pinch off voltage, giving a large dynamic range. Also, the J-113's channel resistance is only 100 Ohms maximum. Points X and Y may go to additional switching FETs, and all sorts of switching schemes could be devised. For instance, if points B and C are connected together, the switching circuit becomes an A-B box, with A and D as inputs (or outputs) and BC as the common output (or input).

## Parts list

Resistors (all 1/4 Watt, 5% preferred)

R1, R2	4.7k
R3, R4	22k
R5	75k
R6	100k
R7 - R10	470k
R11 - R14	1M

Capacitors (greater than 15 working Volts)

C1 - C3	0.047 uF (mylar preferred)
C4 - C7	0.1 uF
C8	10 uF (electrolytic)

## Other parts

Q1	2N5089 NPN transistor
Q2, Q3	J-113 FET (National)
IC1	CD4007
D1, D2	1N4148, 1N914, or equivalent
D3	Red LED
S1	Momentary action momentary switch

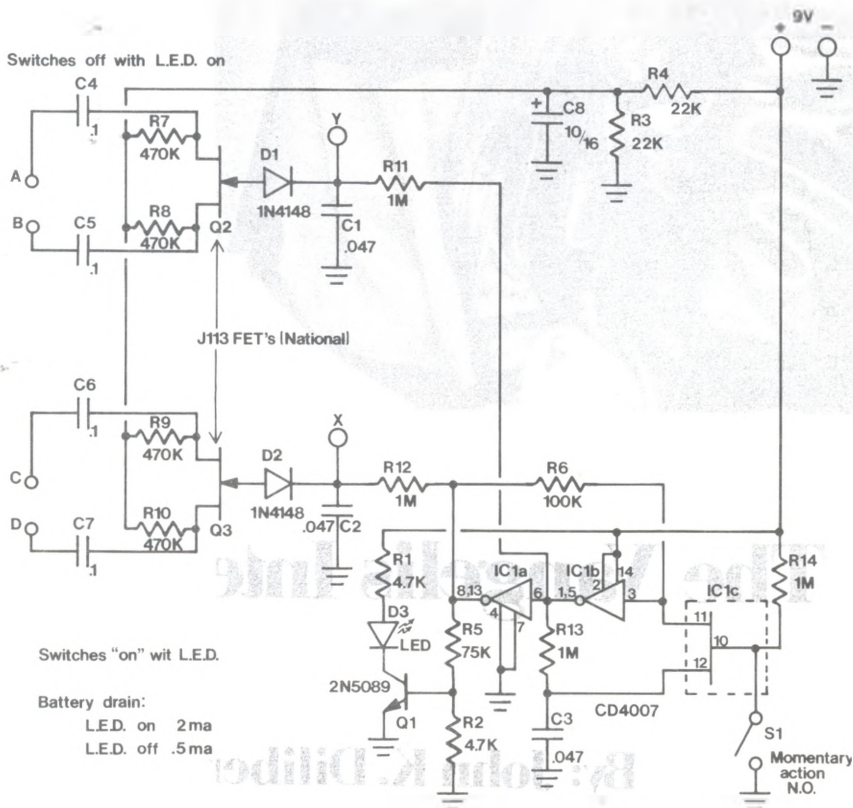
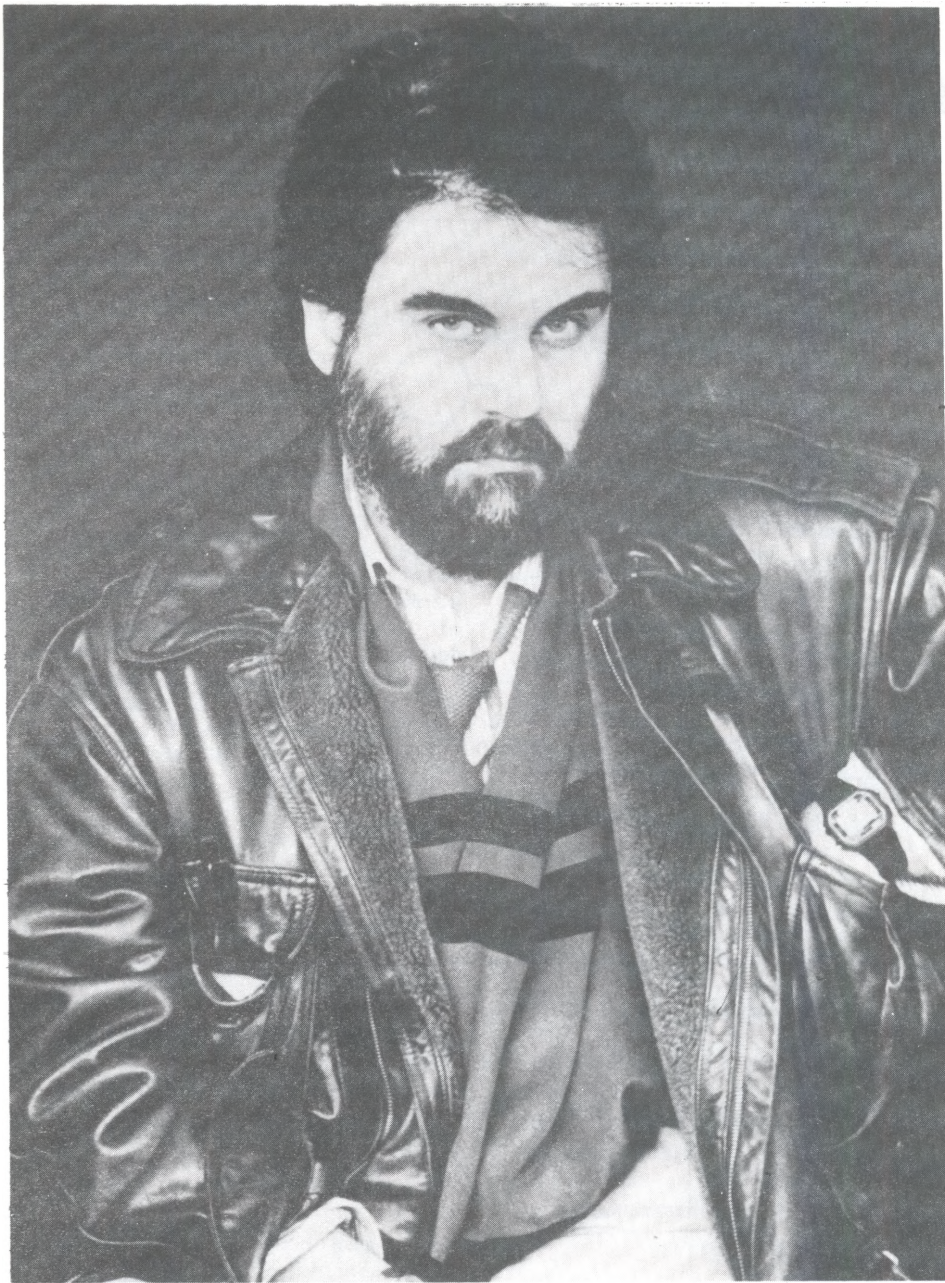

figure 1





# The Vangelis Interview

By: John K. Diliberto

**C**hariots of Fire was the 2001: A Space Odyssey Theme (Thus Spake Zarathustra) for 1982. You couldn't get away from it or its many imitations. It was on beer commercials, bank commercials, and Xerox commercials -- but Chariots of Fire was also a sweeping and powerful Academy Award winning soundtrack, a number one single and album, and one of the more light-weight pieces that Vangelis has recorded over the last 10 years or so. Suddenly, my mother, who thinks that Wayne Newton is high art, was telling me about this Vangelis guy; someone who has been a cult favorite for those who love portentous and grandiose synthesizer music.

Vangelis has played the role of a one-man symphony orchestra for nearly a decade, releasing over a dozen solo albums in that time. His music can be outright imitative with swelling string sections and clarion trumpets (Heaven & Hell) or totally abstracted electronics (Beaubourg). However, his best music falls inbetween, merging cultural influences from Greece and Asia into deftly orchestrated tone poems like China and Odes.

Vangelis approaches synthesizers as a keyboard virtuoso. Although he rarely gives concerts, most of his music is recorded and played in real-time. Vangelis sits in the midst of his 24 track studio surrounded by more than 8 keyboards (mostly Prophets and Yamahas), plus electronic percussion, and dashes out his works with fingers leaping from one keyboard to another. He sets up an off-hand sequencer pattern from a Prophet, rolls in the tympani on his Emulator, pumps out brass from the Prophet 10, while a searing string melody cries out from the Yamaha. I had thought he was giving me a spontaneous concert, improvised on the spot, but I later learned that he whips out pretty much the same routine for anyone who will listen. But it accounts for one of the reasons why his music is so fraught with emotional outbursts: he doesn't distance himself from his music, coolly layering in single-lines on his multitrack. He just leaps into it.

Vangelis is a garrulous man whose physical presence is as massive as his music. Even in his own Nemo studios where he was working, he was dressed in suit-coat and tie, and looking slightly uncomfortable as his body tried to



burst out of it. He smoked one of those thick stogey-type cigars that carnival barkers usually stick in their mouths. Though he was a pop star in his early days with Formynx in Greece and Aphrodite's Child in France, he takes pleasure in eschewing that image. Now he tries to be the common, cosmic man. He denies any importance his music might have, and plays down his recent celebrity, but skillfully navigates questions about his art towards the universal significance of music, the spontaneous nature of his inspiration, and his need to express feelings and emotion. He diverts questions about his birth by saying he is 3000 years old, "or more" (he's in his late-thirties). His charm is that he doesn't come off as pretentious in saying any of this. Instead, he emerges as a warm and thoughtful artist, who really just wants to make music and have a good time.

Vangelis distances himself from the industry. With the final Aphrodite's Child album, 666, a minor art-rock classic, he took the leap away from the commercial scene, doing music that wouldn't get him much airplay except as the background for commercials. He's even expressed skepticism about the success of Chariots, thinking that people will expect all his albums to be like that. That may be why he hasn't put out a new record in well over a year. On the other side of the coin, however, he does make cute pop records with former Yes singer Jon Anderson such as The Friends of Mr. Cairo.

Synthesizers have helped eliminate the need for manual virtuosity, and programmable synths are eroding the need even further. Perhaps Vangelis, with his formidable (and reputedly self-taught) chops is still a reminder that there's still a lot a musician can do with sound, just using one's hands and mind. For Vangelis Papathanassiou, the way he makes music hasn't changed much since he first started beating on a piano and plucking its strings when he was four.

\* \* \* \* \*

**John Diliberto:** When did you first start playing music?

**Vangelis Papathanassiou:** I think I started at the age of four. It was something natural. I remember playing the piano and whatever I could find in the kitchen; any-

thing that could produce noise. I used to play tunes, my own tunes. And I'd open this big grand piano we had at home and I'd pull on the strings and create incredible noises and sounds. I'd drive my mother crazy because she thought I'd break the piano, but I never did. I'd done all this with great respect. I never banged the piano. I always tried to create more sounds, but not in order to destroy it. I was never 100% satisfied with one sound, the conventional piano sound. At that time I didn't have synthesizers, but I always felt that I wanted more than the conventional sound. So my own way of finding new sounds was to go inside the piano. Of course, when I got the synthesizers, everything changed.

---

***"I never felt that I wanted to be like a symphony orchestra musician, which is just like being a really fine and great computer who can interpret any piece of music."***

---

**JD:** Did you have any formal musical training?

**VP:** No. My parents tried desperately to push me towards music lessons but they failed completely. To me it was impossible to sit down and learn. There are things that you can never learn, just like there are things you can never teach. Also, I never felt that I wanted to be like a symphony orchestra musician, which is just like being a really fine and great computer who can interpret any piece of music. To me music was a completely different matter.

**JD:** Was the classical role model the only one available to you at the time in Greece?

**VP:** Of course classical music has always been around, and ethnic music, too. That's really an incredible source of inspiration. Jazz music as well! I remember being 12 years old and I could play any jazz tune and improvise. I always believed that jazz is one of the greatest musical languages. It might be the greatest thing that the United States has ever produced.

**JD:** Who were you listening to?

**VP:** Oh, everybody! Charlie Parker, Thelonius Monk, Errol Garner, Oscar Peterson, Ella! You know, everybody. Count Basie...you could go on forever.

**JD:** When did you start playing for people?

**VP:** When I was six, I played for about two thousand people with a piano.

**JD:** Was it a recital?

**VP:** Yeah, but I was playing my own music, because I couldn't learn anything else. I could only improvise. Even now, when I give a concert, I never know what I'm going to play. I compose for the moment of the concert. And I did the same thing when I was six.

**JD:** How did you get from that point to Aphrodite's Child?

**VP:** It was a natural development, getting together with some friends from the university. We formed this group mainly so that we could play jazz. It was basically an amateur group. We never thought about becoming professionals or making money. But strangely enough, we became so famous in Greece that we were playing before 10,000 people in stadiums. I felt this sort of hysterical success; people screaming, having bodyguards, all the usual things. But that was my first experience with huge success. I was lucky to have this experience early. It was like a vaccination.

**JD:** Were there groups similar to Aphrodite's Child in Greece?

**VP:** There were some but not many. That's the reason why I left Greece and came to Paris and London. It's a great place for inspiration, but you can't develop yourself there. Also, music was not a number one priority in Greece when I left.

**JD:** It was also politically tumultuous then.

**VP:** Yes! That's another reason why I left. I couldn't stay there.

---

***"Most of the things I do are spontaneous. I don't want to prepare myself because then I lose the surprise. That's the way I work."***

---

**JD:** The 666 album by Aphrodite's Child was a pretty bizarre affair.

**VP:** Yeah, that was the last album. Actually I would've liked that to be the first album, but first we had to go through that hit parade thing to prove that we could be commercial and sell and make it easy with the record company. To me, Aphrodite's Child was a vehicle to break into the business and get enough money to have my own studio later. That's the reason why we did 666 in the end, though I didn't know it was

the end. I created a terrible panic. We used to be number one in the charts and they wanted to know why we were doing this, coming out with a double album that was not a single or easy chart album. To me it was a chance to break away and do whatever I liked. I was tired of trying to be in the charts. There's nothing wrong with charts, but it's wrong to try and do the things that you think will get you in them.

**JD:** How did you arrive at a piece like (Infinity)?

**VP:** Quite accidentally. Most of the things I do are spontaneous. I don't want to prepare myself because then I lose the surprise. That's the way I work...

**JD:** Was Irene Pappas' vocal improvised then?

**VP:** Yes. She came into the studio one day and we had this text from the New Testament which was "I was I am to come". Because the 666 album is from St. John, the Apocalypse. She improvised and I played the percussion.

**JD:** A lot of your music is involved with imitative synthesis. It seemed to really start with the Heaven & Hell album with the giant orchestral sounds and trumpets.

**VP:** Actually, when I did Heaven & Hell, I had the smallest collection of instruments. I did it with one or two synthesizers. It was the end of 1974 when I moved to London and was in the middle of the chaos of building a studio. But I had to deliver this album. I did try to produce this orchestral, big sound; but I don't do this all the time.

---

***"Today, to play a synthesizer the right way you need the same amount of technique you would need to play a violin, trumpet, flute or any conventional instrument."***

---

**JD:** When did you first start playing synthesizers?

**VP:** It was in early 1970. It had always been my basic need for years to find an instrument that could give me an extension of sound. The only solution to me was the synthesizer. Of course, at the time, the synthesizers we had were not nearly as flexible as the ones we have now. Now we have real instruments; at the time, they were very basic. Today, to play a synthesizer the right way you need the same amount of technique you would need to play a

violin, trumpet, flute, or any conventional instrument. That is due to the touch response. The keyboards are so sensitive now, and you can really put a lot of feeling into them.

It's really quite extraordinary, because synthesizers are only 12 years old or so. Now, the piano, the most known instrument, took maybe 200 years to build. So it's extraordinary that in 12 years time we've built synthesizers that we can consider really fine instruments.

**JD:** You do bring a strictly keyboard approach to playing the synthesizer.

**VP:** Yes! Because the way that you can drive, you can play the instrument. I'm not very keen on programming a lot of things because then I don't have time to play. The human element is very important. I love technology to serve me, but I don't want to serve technology.

**JD:** So you find that the interface with your synthesizers takes place on the keyboard?

**VP:** Yes! I always believed that the human being is the best synthesizer. The machine is always second.

**JD:** What was your first synthesizer?

**VP:** It was a very small, basic Korg. I still have it.

**JD:** A lot of people see the synthesizer as being able to go beyond conventional instruments, yet you often use it to imitate.

**VP:** You can do both. You can never really imitate. Even if you try to have a symphony orchestra sound, the same thing played by a symphony orchestra sounds completely different. It's more like a memory of what we know, but it's not the real thing. But it doesn't matter. What matters is if you're making communication. If you need a violin, you take a violin. But now with a synthesizer you have the memory of a violin and that's a different thing altogether.

Conventional instruments will always be around because they are a tool to help a human being express himself. So when you have a flute that has been around for thousands of years and it's still there, there must be a reason. I don't think that any synthesizer will put the flute out of business. The flute is a machine as well; it's something that has been built to produce sound. But whenever you play the flute, you can only get the flute sound. The

only thing you can change is your personal feeling, because nobody plays flute the same way. That's the fantastic thing about it, especially in oriental music. The interpretation and the feel that you put into it is very important. So it's a completely different approach.

---

***"Synthesizers can add to what exists now. They're not here to wipe away conventional instruments — they are all machines and it doesn't matter if they are electronic or acoustic."***

---

But when you want to extend that, you need something more. So synthesizers can add to what exists now. They're not here to wipe away conventional instruments -- they are all machines and it doesn't matter if they are electronic or acoustic. With the violin you have a bow and the string that produces the sound. With the synthesizer you need electric power to do the same thing. So what! Some people say that if it's electronic it's not real. Everything is real. The whole cosmic system is like that. It's energy, power. The human being is full of energy and electricity; there's nothing wrong with that.

---

***"I don't believe that synthesizers don't have feeling."***

---

The human being is the master and if you have a feeling, you'll always find a way to get it through. Let's take percussion. To some people, percussion is just noise. To me, percussion is one of the finest assemblage of instruments that humans have ever produced. If you take a conga drum, somebody can just start banging and it will sound awful. But if you take somebody with feel, African or Cuban people, they play it incredibly. This one or two tone instrument becomes so incredible and rich when these people start to play. A simple sound becomes huge. So I don't believe that synthesizers don't have feeling.

**JD:** Don't you think, especially with the newer computer synthesizers, that music is more a creation of the mind? That people's perception of good music doesn't rely on manual dexterity and flashy technique anymore?



**VP:** I think that music is a reflection. And if people become too intellectual it reflects not only in their music, but in their everyday life. We live in an intellectual society anyway. That's why we suffer. That's why we become schizophrenic. There's too much logic and point of reference and fear. Nobody dares to feel something. That's why music has become so important in the last thirty years: it may be the last source of communication between people. We should keep a balance between the intellect and feeling. Use the intellect to analyze something we did after it is done to see why and how we did it. If we don't use it to create what we're going to do, we can come up with a piece of music that really makes sense and then someone else can understand it. If our intent is intellectual, I don't think we can have a dialogue.

**JD:** What I meant was that music is created in the mind, not necessarily intellectual music.

**VP:** But I don't think about my music. It is there before me and after me. I'm somewhere in the middle and I'm like a wire, like a bridge between something. What I do is help this existent thing come through so we can hear it. But I try to eliminate the filter and keep the music as pure as possible. But it's very difficult.

Music is very important. I never see it as entertainment. It could be entertainment, but that's a small percentage of the whole spectrum of music. The way that we use music today is very little. We use music in a very narrow way at the moment. Hopefully they'll use it in different ways in the future.

**JD:** What sort of ways?

**VP:** Science!

**JD:** How will they use it in science?

**VP:** Oh, they will. Because music is like a code. It contains all the secrets, things we don't understand (Editor's note: Gurdjieff believed that certain truths were coded into the standard, 12 tone Western scale). Until now, we used lots of philosophies to understand certain things. But music is there like a witness to all creation.

**JD:** One aspect of your music, and a lot of electronic music is that it's not just concerned with the construction of sound, but also the placement of sound in space.

I'm thinking especially of Beaubourg, which is a very abstract piece, but creates this movement of sound through the stereo spectrum.

**VP:** Of course, with the technology that we have today, it gives us a new way of recording. It's the same as recording holograms, three dimensional. You feel like you're in a globe. It's better in quadraphonic sound where everything is there and you know the position of every sound. At the time I did Beaubourg, I used only stereo. I'd love to use quadraphonic, but I can't because most people aren't equipped with the equipment to hear it the right way.

**JD:** Do you think your ideas are ahead of the technology?

**VP:** No, the technology is fine.

---

***"My job is not to give concerts, but to live as freely as possible so that I can create."***

---

**JD:** You don't think that synthesizers could improve in any way?

**VP:** Oh, of course they can. But it's a business thing. With synthesizers, every year they give you a little bit more so that you'll continue to buy more, because the companies have to survive.

**JD:** You don't perform live anymore.

**VP:** No, I don't. The last concert I gave was about 4 years ago. It's a real hassle to play live. When I decide to do a concert, I go through a lot of problems with publicity, interests, money, the sound...this simple idea of getting together with people becomes a monster of problems. It's not spontaneous anymore. I'm sure you've been to lots of concerts, and you know that backstage it's completely different than it is out front. I can't go through that. I also can't plan far enough in advance to do a concert. I don't like to commit myself. My job is not to give concerts, but to live as freely as possible so that I can create.

**JD:** What about the technical feasibility of performing your music live?

**VP:** No, performing live is no problem technically. With the new technology it's even less of a problem.

**JD:** An album like China was quite a departure for you. What was it like, trying to bring the music of

an alien culture into your own art?

**VP:** I always felt very close to Chinese music, even as a child. Of course, all ethnic musics have common points, but I've always been attracted to Chinese music. I didn't try to do Chinese folk music. I'm not Chinese, but I did something that I felt had this characteristic color of Chinese music.

**JD:** It was very gentle music, compared to, say, Heaven & Hell, which was very dynamic.

**VP:** Heaven & Hell is European music.

**JD:** Do you think that Asian music lends itself to the synthesizer in that the synthesizer can go beyond the diatonic scale?

**VP:** Absolutely. I know, because I play Oriental music and I can do the same things on synthesizer, much more than I have on my albums. But when I just play for myself, I find that I can have the same flexibility of a sitar, shakuhachi or any other Oriental instrument. It's a different technique altogether. You take a violin, which is a very conventional instrument -- the Egyptians play it one way, the Indians another and the Greeks another. You can even play jazz on violin. It's the same instrument, but it has a different feel and technique. Today, with the touch response synthesizers, if you know how to use the technique, you can produce the same results.

**JD:** When Edgar Varese was thinking about an instrument like the synthesizer before there was such a thing, he talked about the liberation of sound. Do you think has accomplished that?

**VP:** As long as the human being is free, yes.

---

***"In order to leave room for each family of frequencies to grow, you have to be as simple as possible. These are basic laws. It's not my conception, it's how nature works."***

---

**JD:** Do you like to use the synthesizer in ways that human players couldn't perform with conventional instruments?

**VP:** In terms of speed, yes. A human being is a machine as well. You have ten fingers if you play the piano, four fingers if you play the violin and you have to go a certain speed. You have certain facilities and difficulties. Now

with the synthesizer, especially ones that you can program, you can alter the speed in the mechanical parts. And by changing the sound, and programming the change in the sound, you can program in things that the human being can't produce. But what the hands can't produce, the mind produces. When I think about a symphony and I have to write something that's an hour long, I can think about this music in an hour's time in my brain. So I've done it. Now, we're not talking about whether it's good or bad, but mechanically, my brain has done it. Now to put that into practice it might take a year or six months. I have to write the piece and rehearse it and all that. But I believe that the real composition takes place in the mind. I have many symphonies that are lost like that but it doesn't matter. So the human being is able to think.

The greatest machine might be to have a plug that you put in your brain and you immediately have a recording. But this wonder doesn't exist. It might even be dangerous.

**JD:** What do you think?

**VP:** It would probably be dangerous. Human beings are very unstable.

**JD:** A lot of the electronic music to come out of the mid-70s was involved with space and technological imagery and you were involved with that too, around the time of *Albedo 0.39*.

**VP:** That's one of my interests. But it gets a little bit dodgy when you go to space and all that with synthesizers. We created a fashion of electronic music in space. And it's true that with electronic instruments you can get closer to nature and nature is space, it's everything. But it became a fashionable thing and that's why I don't repeat it.

**JD:** When you say you write music, do you mean that you actually write it out?

**VP:** No, I don't write it out. I don't know how to write music.

**JD:** Do you compose at the keyboard?

**VP:** I compose right on the keyboard. And it's always the first take that I use. It's a question of concentration and then I play.

**JD:** You say you use the first take, but you must do lots of overdubbing.

**VP:** Yeah, but not alot. I don't play one synthesizer at a time. I play three or four. So immediately you have a spectrum of

sound. Then if I need more things I overdub. But I never do ten overdubs or anything like that; just two or three. If you do more than that, it becomes dull. You can have a really full sound with only a few things. It just depends on where you put them. With a symphony orchestra you can have a really full sound with only three or four voices. You don't need 20 voices singing parallel lines -- this creates a thin sound because you cancel things. In order to leave room for each family of frequencies to grow, you have to be as simple as possible. These are basic laws. It's not my conception, it's how nature works.

**JD:** A couple of years ago, we were sitting in the United States, a car commercial came on, and we said "hey, we know that music".

**VP:** Oh yes! In Europe you can't imagine what it's like. All of my albums are used by everybody, in every country. It's embarrassing actually. Thank God that they don't mention my name.

**JD:** It seems that in the last year they've been using different versions or re-mixes of some of the pieces.

**VP:** Yeah, they are different versions.

---

***"To me, the synthesizer is the same as natural sounds, like thunder, the wind and water. Electricity! Energy! I really like living in this century where I can enjoy all these instruments."***

---

**JD:** Your music does elicit strong visual responses.

**VP:** But when I play I don't see anything. I feel things in terms of waves, electricity, magnetism, mass and like that. I see things after, when I listen back, but not when I compose.

**JD:** What do you like to listen to?

**VP:** I listen to things that are very simple, like the Blues or Indian music. Arabic and Greek music is simple. With Oriental music you have an abstraction. Blues is an abstraction as well. It's unbelievable what you can do with the blues.

**JD:** Do you listen to any other electronic music?

**VP:** I listen to nature and natural sounds. To me, the synthesizer is the same as natural sounds, like thunder, the wind,

and water. Electricity! Energy! I really like living in this century where I can enjoy all these instruments.

**JD:** I find it interesting that you're into the blues.

**VP:** I've never done an album of blues.

**JD:** Would you want to?

**VP:** Oh, I'd love to.

**JD:** Do you think people would take it seriously?

**VP:** I don't know. I do whatever I feel. If they take it seriously or not is not up to me. Of course people put on labels, and I hate labels. One of the big dangers after *Chariots of Fire* is that people will think that my next album is going to be like that. Every time they call me to say that I'm number one here, and platinum there, I get terrified that I might be stuck with that. How am I going to convince thousands of people that it is just one moment during a month's time?

**JD:** Do you think that electronics might be paving the way for a more universal music?

**VP:** To have a universal music we have to feel universal. We'd have to get rid of our everyday points of reference and beliefs. It's okay to be English, Greek, or American but we have to see that we are all on earth and we are all one.

**JD:** I sometimes think that the synthesizer could be a tool for breaking down the barriers.

**VP:** It can be. Until now, what conventional instruments have done is help the human being to develop his own language or dialect. So if I spoke to you now in Chinese or Greek you won't understand anything; I could say the most beautiful thing and you would not understand. That's why, when you have, say, a great piece of Indian music, people aren't able to receive it. But with synthesizers, you can go beyond this. We can keep the roots of something and then you don't have to apply the precise language.

I have an example of that on an album with Irene Pappas (*Odes*). It's done with very old, Greek traditional music. Until a few years ago, everyone used to play this music with the traditional instruments and it was like a museum piece. Because of that, the music dies every day. Now I played that music that I learned when I was three or four and I

continued on page 33



# CURRENT EVENTS

*'Tell Them You Saw It In Polyphony'*

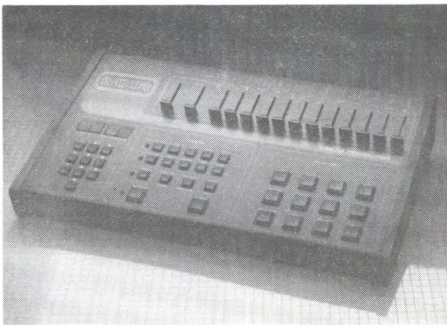

**New drum machines.** The \$1250 MXR Drum Computer (Model 185) lets you create 100 different stored patterns, which can be combined to form 100 different songs. The twelve sounds have individual play buttons for real-time "recording" (programming), individual outputs and trigger inputs, cassette and sync interface, and sliders to control the overall mix.

The \$1395 Oberheim DX also stores 100 patterns; these can be combined into 50 songs. The DX includes 10 digitally recorded drum sounds with individual outputs, many with selectable accent and dynamic levels.

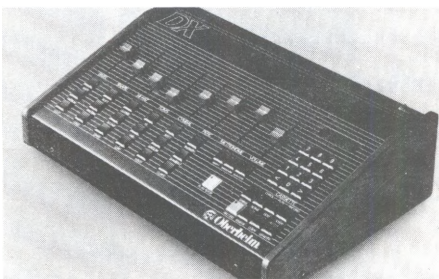

**Motorola filter chip.** Motorola (3501 Ed Bluestein Blvd., Austin, TX 78721) has announced the MC145415, a 16 pin dual low-pass switched-capacitor filter. It includes two five pole filters, and operates off single supplies from 4.5 to 16 Volts (or a +5V split supply).

**New recorders.** Fostex will soon introduce the X-15 Multi-Tracker, a portable four channel recorder which weighs in at 4.4

lbs., includes Dolby C, may be battery or AC powered, and can record up to two channels at one time. List price: \$495.

Fostex has also developed a 16 track recorder which records on 1/2" tape and comes with Dolby C. The list price is under \$6000; options include +4 balanced outputs, dbx instead of Dolby, and a remote control unit.

**Semicustom switched-capacitor filter chip.** Reticon (345 Potrero Ave., Sunnyvale, CA 94086) has introduced the R5626, a semicustom circuit which, with a single mask change, can implement virtually any filter network. It includes 14 second-order switched capacitor filter sections, three uncommitted op amps and capacitor arrays, 20 digital cells with six I/O buffers, and various clock options (TTL/CMOS master clock or crystal oscillator). Frequency range is from 0.5 Hz to 30 kHz, Q is variable from 0.1 to 250, and dynamic range is claimed as 85 dB. The R5626 requires a bipolar supply from +3.5 to +11V. Cost is approximately \$30 per piece at the 1000 piece level; there is also a one-time tooling charge, which can be as high as \$30,000.

**Intellivision add-ons.** Mattel now offers the Intellivision Computer Adapter, which connects directly to the Intellivision and Intellivision II master component units. It includes 2K additional RAM, 12K of ROM with built-in BASIC, and an extra sound generator to give the Intellivision six sound channels. A Computer Keyboard comes with the adapter at no extra cost, but a more interesting keyboard is the 49 note, full-sized organ-style keyboard which is also available. This turns the Intellivision system into a six note polyphonic synthesizer. Software available now includes "Astromusic" (educational game), "Melody Maker" (music composition), and "Music Conductor" (practice drills, interval recognition, and fingering exercises).

**VIC-20 add-ons.** The Genesis Computer Company (Bethlehem, PA) offers the VIController for \$59.95. This allows a VIC-20 (or Commodore 64) to control up to 256 BSR lamp and appliance modules, with up to 9 levels of brightness for the lamps. Sounds like just the thing for computerized stage lighting. Also, Protecto Enterprises (Barrington, IL) offers a VIC-20 compatible Votrax-based speech synthesizer for \$79.95. A software editor which allows adjustment of such parameters as volume and pitch goes for \$9.95 on cassette. Finally, Gloucester Computer Company (Gloucester, MA; tel. 617-283-7719) is selling the PromQueen, a programming tool/PROM burner (2716, 27C16, 2732, 27C32, and 2732A) which turns the VIC-20 into an assembly-language development system. Officially approved by Commodore, it comes with 4K of RAM, and HEXKIT 1.0 universal editing software on EPROM. List price is \$249.

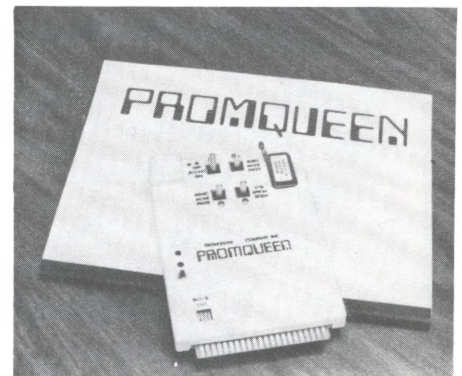

**Better tape on the way.** Several Japanese companies have come up with improved tape formulations. After developing an improved process for microcassettes, Matsushita has started production on standard size cassettes which boast a frequency response of 20 to 30,000 Hz. They use two metals, chromium and cobalt, to provide both high and low frequency performance. In other news, Maxell has developed a ferric oxide particle that is only about



# POLYMART BOOKS

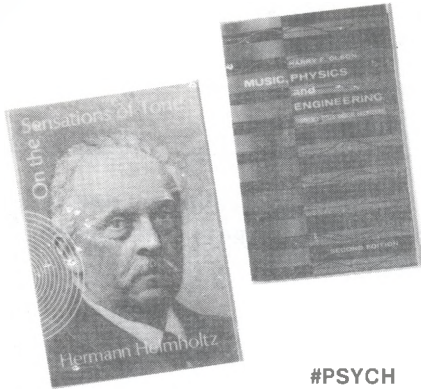
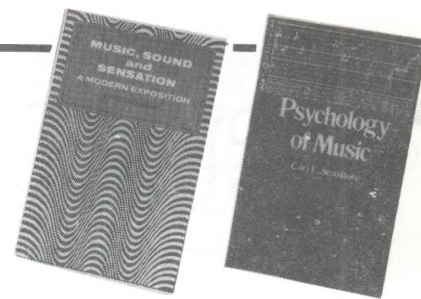

## SCIENCE OF SOUND

The physical and psycho-acoustical background to music is an important part of musical synthesis. Helmholtz's **SENSATION OF TONE** is, a century after its publication, still the standard text for the physiological acoustics. **PSYCHOLOGY OF MUSIC** by Carl Seashore, developer of the Seashore Music Test, provides an in-depth analysis of musical style and performance characteristics of many instruments. **MUSIC, PHYSICS AND ENGINEERING** by Harry Olson, who worked on the first RCA synthesizer, is a thorough discussion of the physical properties and design of traditional musical instruments (plus a chapter on electronic music). **MUSIC, SOUND AND SENSATION** by Winckel is much like the Helmholtz work, with a bit less detail and more concentration on psycho-acoustics.

#PSYCH	PSYCHOLOGY OF MUSIC	\$6.00	#SENS	ON THE SENSATIONS OF TONE	\$8.95
#MSS	MUSIC, SOUND AND SENSATION	\$4.50	#MPE	MUSIC PHYSICS AND ENGINEERING	\$6.50

## REFERENCE

Often used reference materials to answer the many questions encountered in everyday synthesis. **THE SOURCE** Book of Patching and Programming from Polyphony has over 125 pages of patches in universal flow chart notation; the largest publication of its type. **AUDIO CYCLOPEDIA** has 1760 pages with 3650 entries and hundreds of drawings and schematics to answer any question about ratio. Hardbound. **ELECTRONIC MUSIC SYNTHESIZERS** by Delton Horn devotes the first half to descriptions and functions of commercial electronic music synthesizers (Moog, Arp, PAIA, Oberheim, EML, and RMI); the second section provides schematics and projects for the experimenter.

#SOURCE	THE SOURCE	\$4.00
#CYCLO	AUDIO CYCLOPEDIA (hardbound)	\$44.95
#EMS	ELECTRONIC MUSIC SYNTHESIZERS	\$6.95

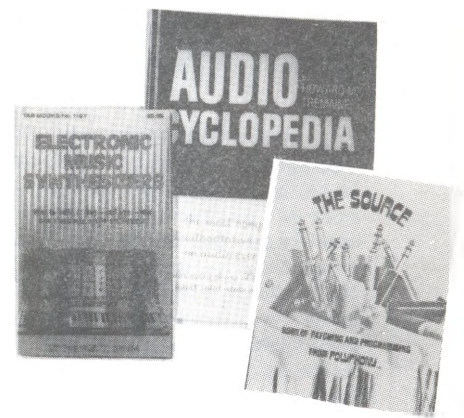

## TECHNIQUE

Synthesists must be well versed in a number of techniques and principles. "How To" and project oriented books are a great way to pick up these skills. **MULTITRACK PRIMER** by TEAC is a step-by-step guide to building, outfitting and operating your home studio. The Byte Book of **COMPUTER MUSIC** describes computer control of electro-mechanical instruments, Fourier analysis, circuits and loads of software. **HOME RECORDING FOR MUSICIANS** is Craig Anderton's original guide to outfitting and operating a budget studio for maximum results, includes mixer and other audio processing circuits and a sound sheet demo recording.

#TEAC	TEAC MULTITRACK PRIMER	\$4.95
#BYTE	BYTE BOOK OF COMPUTER MUSIC	\$10.00
#HRFM	HOME RECORDING FOR MUSICIANS	\$11.95

## "HOW TO" GUIDES

**HOW TO BUILD A SMALL BUDGET RECORDING STUDIO FROM SCRATCH** by F. Alton Everest covers twelve tested designs. **HOW TO DESIGN TEST AND BUILD COMPLETE SPEAKER SYSTEMS** BY David Weems is a do-it-yourself guide for the ultimate in sound quality. **HOW TO MAKE AND SELL YOUR OWN RECORD** — With the major labels having severe economic problems, many insiders feel that the future of the music industry may be in independent record production. Learn the ropes with Diane Sward Rapaport's indispensable handbook of how to get started. **MAKING MONEY MAKING MUSIC** by James Dearing — Everyong dreams of being at the top, but there's an enormous amount of "middle money" out there for the taking. This is not a book about how to become a Millionaire Rock Star, but the strategies revealed will give you the knowledge you need to keep afloat if you decide to pursue a recording contract. A fresh and practical approach to staying alive in the music business. From the publishers of Writer's Digest.

#BRS	BUDGET RECORDING STUDIO	\$9.95	#MASR	MAKE & SELL YOUR OWN RECORD	\$11.95
#CSS	COMPLETE SPEAKER SYSTEMS	\$7.95	#MMM	MAKING MONEY MAKING MUSIC	\$12.95

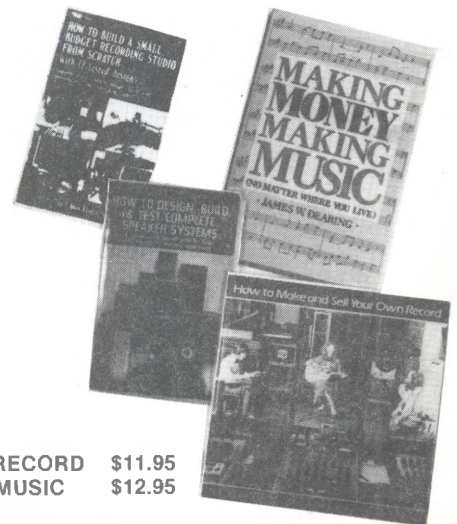

**ORDER FROM: POLYMART, P O BOX 20305, OKLAHOMA**



# USE THE ORDER FORM ON THE NEXT PAGE

## ELECTRONICS

Electronic Cookbooks are a great way to stock your library with materials that are not only heavy on theory, definitions and educational material but chock full of practical applications as well. These books can easily replace stacks of manufacturers data sheets and applications notes all in an easy to use reference. Walt Jung's **OP-AMP** and Don Lancaster's **ACTIVE FILTER** Cookbooks are self-explanatory — required reading for synthesists! **AUDIO OP AMP APPLICATIONS** is an edited version of the Op Amp Cookbook by Walter Jung, containing only audio applications. Lancaster's **CMOS** book is much more than a digital reference — phase lock loops, top octave generators, touch switches, and other things you need. **ELECTRONIC PROJECTS FOR MUSICIANS** by Craig Anderton is almost in a class by itself. It discusses electronic construction technique for the novice and provides 27 projects with printed circuit board patterns and a demo recording of the effects. Even if you're an old hand at musical electronics, you'll appreciate that all of these processors, from Tube sound Fuzz to Phase shifter are compatible and work together without creating noise, signal loss, bandwidth compression or any of the problems common to interconnecting effects from different manufacturers. There's even a complete chapter on how to modify and combine effects to produce your own custom pedalboard. **ELECTRONIC MUSIC CIRCUITS** by Barry Klein covers synthesizer system design, power supplies, control voltage generators, VCOs, Filters, analog multipliers and more. Lots of schematics and data sheets on the most popular music oriented ICs. An excellent technical reference.

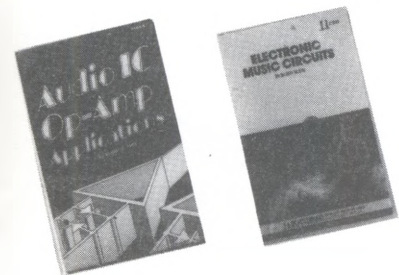
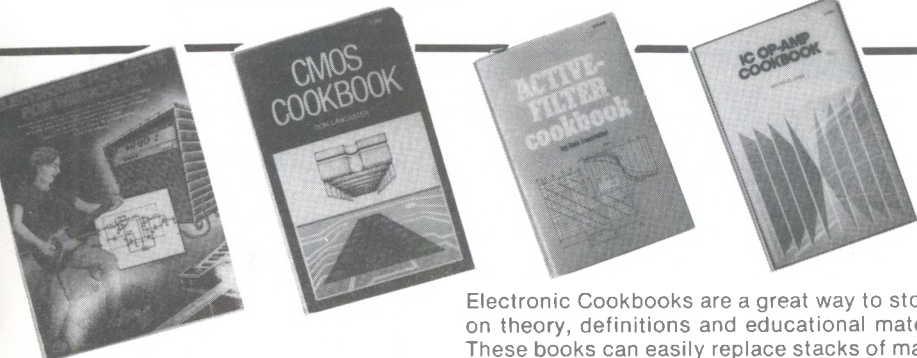

#OACB	OP-AMP COOKBOOK	\$15.95	#EPFM	ELECTRONIC PROJECTS FOR MUSICIANS	\$14.95
#AFCB	ACTIVE FILTER COOKBOOK	\$14.95	#EMCR	ELECTRONIC MUSIC CIRCUITS	\$16.95
#AUOA	AUDIO OP-AMP APPLICATIONS	\$8.95	#CMCB	CMOS COOKBOOK	\$12.95

## EXCITING NEW BOOKS!

**MUSICAL APPLICATIONS OF MICRO-PROCESSORS** by Hal Chamberlain — If you only have space in your library for one book on music synthesis, this is the book. The easily read text is entertaining and enlightening and teaches both basics and advanced theory without plowing through pages of equations. Liberal examples illustrate theory and practice of both digital and analog signal generation and processing.

#MAM **MUSICAL APPLICATIONS OF MICRO-PROCESSORS** \$19.95

**THE COMPLETE GUIDE TO SYNTHESIZERS** by Devarahi — An extraordinarily thorough treatment of the subject of analog synthesizers. Covers everything clearly, and the suggested experiments are excellent. Well organized and leaves nothing out.

#CGS **THE COMPLETE GUIDE TO SYNTHESIZERS** \$15.95

**PRACTICAL GUIDE FOR CONCERT SOUND** by Bob Heil — Finally, a manual that explains in very simple language those many "magic terms" you've heard for years and never really understood. It's the first book written especially for musicians, roadies, and sound technicians who want to KNOW and UNDERSTAND what their sound system is all about.

#PGC **PRACTICAL GUIDE FOR CONCERT SOUND** \$10.00

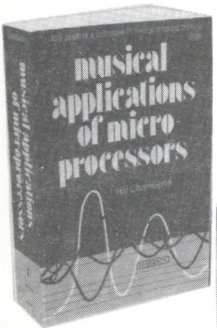

**NEW**

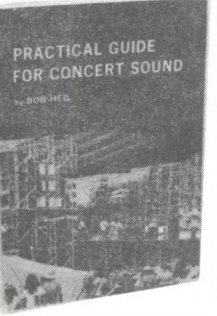
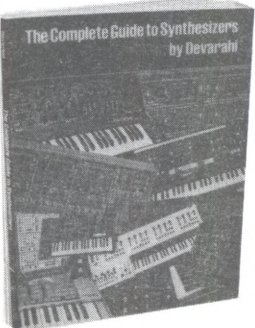

**NEW**

## & MORE FROM POLYPHONY

**4/8TRACK STUDIO LOG BOOK** designed by Craig Anderton provides a place to keep all the important information on your tape library. Log in timing, type of tape used, record patches, make notes and use the expanded track sheet to list sequential changes in tape tracks relating to the settings of the index counter. Craig Anderton's **CONTEMPORARY KEYBOARD ARTICLES** is a collected reprint of all the articles from June 1977 through February 1981, covers tips, technique, theory, maintenance, and numerous construction projects. **DEVICE BACK ISSUES** — during the year that this newsletter was published, it featured almost 200 pages of technical information for the guitarist/musician. A wealth of articles on design, product reviews, and modification and construction projects. Sold in complete set, individual issues not available. Limited number available. **CRAIG ANDERTON MUSIC TAPE** — Delightful listening plus a booklet explaining how the effects were achieved.

#SLB	STUDIO LOG BOOK	\$4.95
#AA	CRAIG ANDERTON'S CONTEMPORARY KEYBOARD ARTICLES	\$5.95
#DEVICE	COMPLETE SET (12) DEVICE BACK ISSUES	\$18.00
#CAMT	CRAIG ANDERTON MUSIC TAPE	\$5.95



**A CITY, OK 73156 (405) 842-5480**





# CURRENT EVENTS

0.1 micro long, which lowers tape noise another 5 dB. They claim a bandwidth of 30 kHz even when running the tape at less than 1 IPS. While neither of these formulations has hit the market in quantity, they demonstrate the advances being made in high performance tape products.

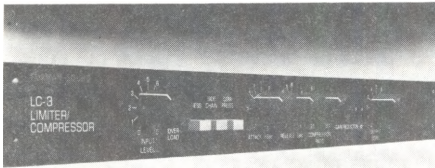

**Low cost limiter.** Furman Sound (30 Rich St., Greenbrae, CA 94904) has introduced the LC-3 Limiter/Compressor. It includes attack, release, and compression ratio controls; LED gain reduction display; "side-chain" and "de-ess" modes; and separate input and output controls. List price is \$335 -- pretty inexpensive for those kinds of features.

**New Buchla.** The new Buchla 406 looks like quite a synthesizer/computer. It includes a five octave pressure sensitive keyboard tunable to "any imaginable scale"; high resolution graphic display; "score editor" that can display, audition, and edit six orchestraly differentiated voices; SMPTE tracking/decoding/displaying; two high level music languages; etc. etc. Introductory price is \$10,500. For more information, contact West L. A. Music, 11345 Santa Monica Blvd., West Los Angeles, CA 90025.

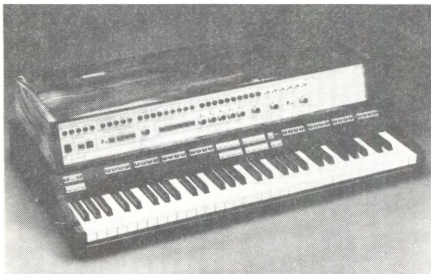

**Loong delays.** At the June NAMM show, DeltaLab (27 Industrial Avenue, Chelmsford, MA 01824) introduced the Echotron, which provides over 4 seconds of delay

and can sync with commercially available drum units. List price is \$699. DeltaLab also introduced the "Effectron II" series, incorporating several new features into their popular Effectron line. Also at NAMM, Electro-Harmonix showed a prototype 64 second rack mount delay which syncs to drums and resembles their currently available 16 second delay.

**EDR redux.** Software Applications, Inc. (5558 S.E. International Way, Milwaukie, OR 97222; tel. 503-653-5927) has bought out the remaining inventory of Imaginearing Audio, and has re-introduced (and will service) the Alphonetone III tuner (\$199.95 list), Alphonetone Jr. (\$99.95), Echo Digital Recorder (\$1995), and EDR remote control (\$600). Discounts are available on factory direct orders. And as the press release says, "Be sure to ask for our EDR demo tape, by Craig Anderton, when you place an order for Alphonetone tuners".



New chord computer makes chords and scales easy. A new hand held computer that displays all common chords and scales has been introduced by Banana. Called the Chord Computer, the list price is \$59.95.

A built in LCD display shows the user how to play any chord, scale, inversion, augmented or

diminished chord, as well as major and minor chords and scales. The user can also transpose any chord or scale up or down by half-steps. Inversions of all chords can be shown, including inversions of 6th, 7th and 9th chords.

According to a Banana spokesman, this product is ideal for portable keyboard owners, music students, synthesizer players, home organists and others. The chord computer can rapidly increase musical knowledge and make it easy for a musician to play in unfamiliar keys.

The Chord Computer is available by mail from PAIA Electronics, Inc., P. O. Box 14359, Oklahoma City, OK 73114 for \$59.95 postpaid.

**Low-cost D/A converters.** Burr-Brown (PO Box 11400, Tucson, AZ 85734) has introduced the PCM52JG-V and PCM53JG-V. These 16 bit D/A converters have been optimized for audio applications and feature a dynamic range of 96 dB. Price is around \$23 in hundreds.

## WIND PLAYERS VOCALISTS

You can use your own instrument or voice to control any standard synthesizer, with more expressiveness than a keyboard.



### THE GENTLE ELECTRIC PITCH AND ENVELOPE FOLLOWER

Write for our free detailed brochure, patch diagrams, and application notes.

Also available as modules for Arjes and Serge synthesizers, or as circuit boards for custom systems. Dealers inquiries welcome.

*gentle electric*

Dept. P  
P.O. Box 132, Delta, CO 81416  
(303) 874-7171

# Practical Circuitry

## A One Chip ADSR

By: Tom Henry

The technology of electronic music is growing so quickly that it is often difficult to keep abreast of all the developments. For example, I thought I was pretty much up to date on most of the important LSI (large scale integration) chips available for music applications, and yet just recently I discovered the SSM2056 ADSR chip. I was amazed when I found out that this IC incorporates all of the design features that my system employs. The supply voltages and input and output levels are 100% compatible with the circuits discussed thus far in this column. And best of all, the complete ADSR circuit can be implemented with one chip! Where have I been all this time?

Before describing the complete circuit, let's stop to philosophize a bit. We've already discussed one ADSR in "Practical Circuitry", so why do we need another? Well, as you continue to gain experience in electronic music, you will find that no two modules are exactly alike. Even two "identical" circuits will have subtle differences that make one more suitable for a particular application than the other. This is most apparent in the case of filters (everybody seems to have a favorite filter), and to a lesser extent with ADSRs. As I found out after building it, this ADSR has quite a different "feel" from my other units. In particular, it seems to offer quite a bit more control over short attack and decay times, thus making it eminently useful for percussion sounds. In general, this ADSR gives me a good feeling; it was easy to build, worked right off the bat, and gives some new effects, too.

**How it works.** Refer to the schematic. The heart of the whole circuit is, of course, the SSM2056. This chip was designed

to operate from our standard bipolar +15V supply, with pin 14 being at +15V and pin 8 at -15V. Since an ADSR has quite a bit of switching going on inside it, fairly hefty capacitors (C3 and C4) are strung across the power pins. While 100 uF may be more than is actually needed, it never hurts to be extra careful when it comes to decoupling (you might also want to solder some 0.1 uF ceramic caps across the supply lines in parallel with these electrolytics for even more effective bypassing of sharp transients-- Ed.).

J1 sends a trigger signal to the chip through R13 and C1. The input signal should be our standard +5V, 1 millisecond wide pulse. The gate signal couples to the IC through closed circuit jack J3. This jack provides a constant +5V gate signal to the chip if no plug is inserted into the jack. (Voltage divider R14 and R12 drop +5V from the power supply.) With the addition of this switching jack, it is possible to fire the ADSR with a trigger only, thus giving AD type envelopes. For most purposes we will want a full ADSR response, but sometimes an AD envelope is more suited to the application at hand. This is especially true for percussion or AMS-100 effects.

If a plug is inserted into jack J3, the constant gate feature is disabled. The plug now presents the normal ON/OFF type keyboard gate to the chip. A little later, we'll see how to make the most of the various types of envelope patterns available with this circuit.

The time parameters are set via potentiometers R7 through R9. Thus the ATTACK, DECAY, and RELEASE times may be easily set with the turn of a knob. Since the hot sides of these pots are hooked up to the +15V power supply line, the wiper voltages must be attenuated.

R4 and R1 form a typical voltage divider. The maximum voltage of +15V is dropped to about 260 mV, a level the SSM2056 likes to see.

The SUSTAIN control is handled a little differently. A fixed 20k resistor (R11) is added to potentiometer R10 to drop the +15V supply line to about +5V. Thus the hottest setting of this pot is at +5V. This in turn means that the SUSTAIN voltage is variable from 0V to +5V, as we would expect it to be. By the way, 20k is a standard 5% value and can be easily obtained from a number of dealers (see below). Do not substitute, say, a 22k resistor for this critical value. (Note that potentiometer resistances are not all that accurate, so you may want to use a meter to make sure that the pot you choose is as close to 10k as possible -- Ed.)

C2 is the timing capacitor for the whole ADSR. Use a good quality capacitor here; mylar is perhaps the best choice, being both fairly stable and not too expensive.

The output appears at J2. I've only shown one jack here, but in my version of the circuit, I actually tied four jacks in parallel for the output structure. You'll probably find, like I have, that you'll often use one ADSR to drive several circuits. So, by making a number of output jacks available, you will get around using up some multiples elsewhere in your system. Four jacks should be the limit though, since this is about the maximum that the SSM2056's internal buffer can handle.

**How to build it.** In the past, obtaining single unit quantities of the more exotic integrated circuits was rather difficult. However, things are easing up now, and you should have no trouble at all. PGS Electronics (PO Box 749C, Terre Haute, IN



47808) is one source; the price is under \$6, although there may be a shipping and handling charge.

The two rather important resistors, R11 and R14 (20k and 200k, respectively) are standard 5% values and can be obtained from a number of places. My favorite source for resistors is Jameco Electronics (1355 Shoreway Road, Belmont, CA 94002). The price is around six cents each for resistors, but you'll have to make sure you meet the minimum order requirements. Write to both PGS and Jameco for catalogs and ordering information.

Since this was such a simple circuit, I built it on an "Experimenter Printed Circuit Board" available from Radio Shack (stock #276-170; about \$3). This is one of those generalized breadboard rigs that has a number of rows of pads and traces suitable for building up IC type circuits. Circuit construction is not critical, since there are no high frequencies present in the circuit. Along with the circuit board mentioned above, I used hookup wire and flea clips to finish the construction.

The one chip ADSR mounts easily behind a standard 1.75" by 19" rack panel. Use some small angles and #4 hardware to fasten the circuit board to the front panel. Since you'll probably have some space left over, you can use this for some one by four multiples; in other words, four phone jacks wired in parallel. Multiples are always handy to have around, so when a chance presents itself like this, seize the moment and throw one in! By the way, if you need some help in preparing a front panel, see my article "Making Rack Panels" (*Electronotes*, Volume 13 Number 122, February 1981, pp. 5-9).

**Using the one chip ADSR.** Since ADSRs may be new to some readers, here are a few settings that you can play around with. For a full ADSR response, apply both a gate and trigger from the keyboard. Now press a key and hold it. The instant you hit the key, the envelope will launch into its ATTACK portion. When the signal reaches +5V, the DECAY portion will start up. The signal will decay to the level set by the SUSTAIN control and will hold there for as long as the key is held down. Now release the key, and the RELEASE portion kicks in.

For an AR type response, once again apply both a gate and trigger. Now turn the DECAY control

down all the way, and the SUSTAIN control up all the way. When a key is pressed, you will get an ATTACK/SUSTAIN/RELEASE pattern, typical of an AR unit.

For AD effects, you need only apply a trigger signal. Turn the SUSTAIN and RELEASE controls down all the way. Now whenever you touch a key, the unit will go into an ATTACK/DECAY cycle automatically. As mentioned earlier, this is usually the appropriate waveform for percussive effects.

Of course, these three arrangements just described are just the start. There are countless other settings of the controls, hence countless other sounds. Let your ear be the judge of which are most appealing to you! And remember, this circuit allows for full retriggering, so the versatility is even greater.

There you have it, a very

complete one chip ADSR! Alert readers will note a similarity to Craig Anderton's "Voltage Controlled Envelope Generator" (*Contemporary Keyboard*, May 1982, pp. 20-23). Craig's circuit used the SSM2055, an earlier generation of the SSM2056 presented herein, and also offers voltage control of the various parameters. If you're looking for even greater versatility (at the expense of greater complexity, though), check out Craig's circuit. But for most common applications, I think you'll find the simple manually controlled version presented here will really fill the bill.

If you're just learning how to build synthesizer gear, you'll find this ADSR is a great project with which to start. Pay attention to the supply voltages, capacitor polarities, watch your soldering techniques, and before you

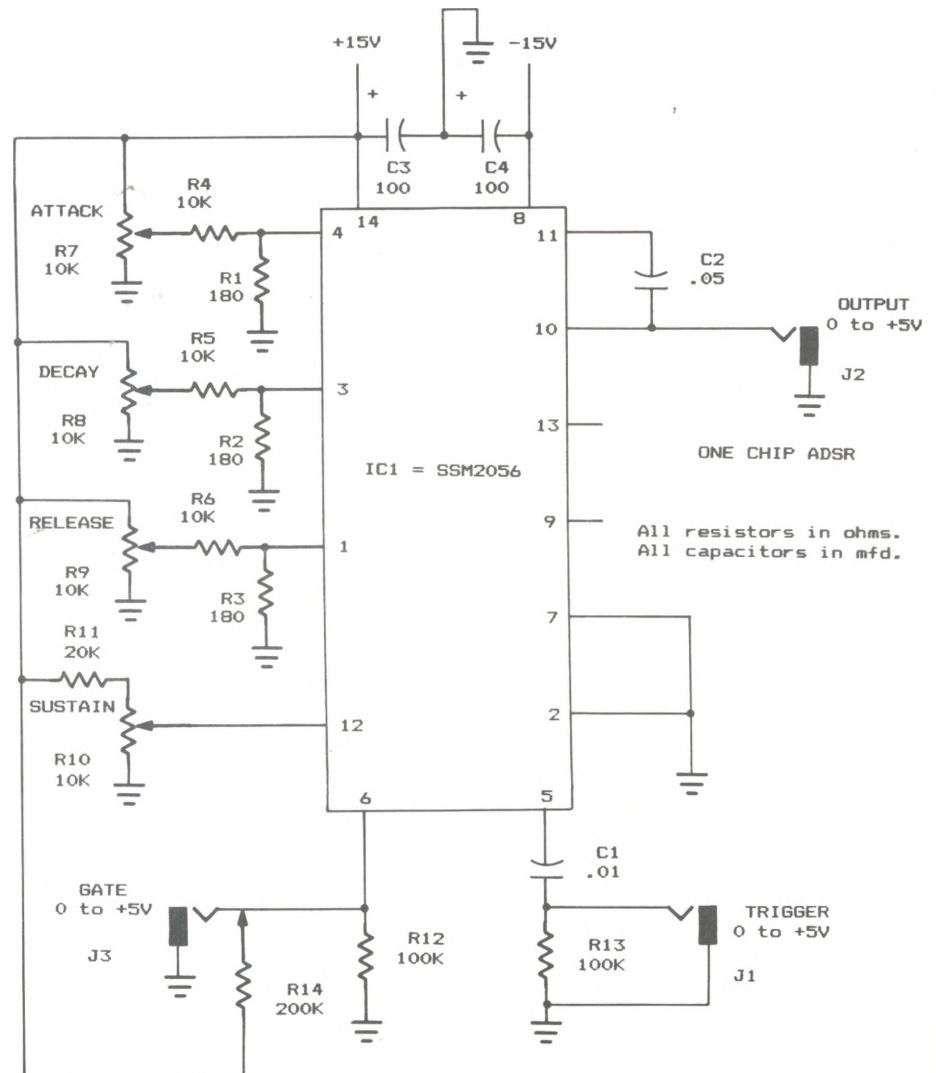

know it you'll have a very professional quality ADSR up and running.

#### PARTS LIST

##### Resistors

R1-R3	180 Ohms
R4-R6	10k
R7-R10	10k linear pot
R11	20k
R12, R13	100k
R14	200k

##### Capacitors

C1	0.01 uF
C2	0.05 uF
C3-C4	100 uF electrolytic

##### Other Parts

IC1	SSM2056 ADSR chip
J1, J2	Open circuit 1/4" phone jack
J3	Closed circuit 1/4" phone jack
Misc.	Circuit board, front panel, knobs, wire, etc.



continued from page 5

George's second question concerned modifying the Casio 202, which was reviewed in your Jan/Feb '82 issue. I was rather surprised you hadn't looked into a modification for this, as I'm sure quite a few of your readers own some sort of Casio that is not of the "mini" type. Casios are quite often owned by those of us who make less than \$12,000 a year. All I can say is if Polyphony can't help, then try J. L. Cooper Electronics, as they are poly-synth modification experts. The address is:

J. L. Cooper Electronics  
2800 S. Washington Blvd.  
Marina Del Rey, CA 90291

In closing, I'd like to say that it would be of enormous help to amateurs like myself if you would write electronic projects with digital-unfamiliar people in mind. I can't see this as being an annoyance with people who are familiar with electronics...give it some thought.

Kenneth Amaris  
Culver City, CA

Kenneth -- You're not the only one who has written recently

continued on page 40

# BOOK REVIEW

The Complete Synthesizer, a Comprehensive Guide by David Crombie, Omnibus Press, 1982.

## By: David Doty

Despite the growing popularity of synthesizers, instruction books suitable for the beginner are still rather rare. This is the role I believe The Complete Synthesizer was intended to fill; but, although it offers a fair amount of valuable information in a reasonably palatable form, this book is far less than its title claims. Virtually all of the functions common to the contemporary analog synthesizer are presented here; and the information offered is, so far as it goes, correct; but something important is missing: the idea that synthesizers are, at best, extremely powerful musical tools whose potential is yet to be fully explored.

The book begins with a chapter devoted to the basic parameters of musical sound. This is as it should be, and the text here is simple and straightforward enough that a reader with no background in acoustics should be readily able to grasp these important concepts. The second and by far the longest chapter is entitled "The Synthesizer Voice Module", a title which is indicative of the book's viewpoint. The synthesizer is presented as a normal, keyboard controlled instrument with the signal path that has been prevalent since the introduction of the minimoog. The various modules are described in terms of the roles they play in this scheme, and alternative possibilities are largely ignored. As a result of this approach, the type of synthesis described here is primarily the imitative sort as practiced in recent rock and pop music. Techniques which fall outside this genre are treated with a certain condescension, when they are mentioned at all. For instance, regarding the LFO, we are told that sine and triangle waves are for vibrato, square waves are for trills, and that "Sawtooth frequency modulation is generally limited to special effects, such as sirens...". Similarly, the sample and hold is represented exclusively as a generator of random control voltages which, we learn, "are seldom used except for bizarre, spacey effects". While these attitudes are typical of a certain style of synthesis that is prevalent today, their presentation in a book such as this, to the exclusion of others, is apt to lead the beginner down a path of well-worn cliches, rather than encouraging creativity and exploration.

The remaining chapters reflect the same bias. Under "Types of Synthesizers" the modular synthesizer receives less space than the "pseudo-polyphonic" top octave divider type instrument, which is not properly a synthesizer at all. "Using the Synthesizer", which might properly have been the longest chapter in a book such as this, receives a mere five pages, with four of these being devoted to imitative voicings. A few recipes are given, including the mandatory string, brass, and organ patches, but nothing is said about achieving the subtle note-to-note and register-to-register differences typical of acoustic instruments. The "Synthesizer Accessories" →



## →BOOK REVIEW

chapter gives an adequate explanation of sequencers, but the portion dealing with outboard effects is unduly brief and rather arbitrary in its inclusions and exclusions. The concluding entry, a glossary, is one of the most valuable items in the book. The entries are extensive and the definitions are concise and non-technical. This is a useful resource for the novice, foundering in a sea of new and unfamiliar terms.

The format of the book is slightly peculiar. Although the dimensions of the page are 9" X 12", the actual text is set in a space measuring 7" X 9.75", surrounded by a border of light blue moire. I do not wish to nit pick, but as this book of 96 pages sells for \$10.95, I would rather have seen all the available space devoted to useful information rather than decoration. The second color, which no doubt increased the book's cost, is rarely used to enhance the clarity of the diagrams and illustrations.

In conclusion, while this book is not without value for the beginning synthesist, it does little to encourage the truly musical use of synthesizers. We are still without a truly "comprehensive guide" that could serve the needs of beginning and advanced synthesists alike.

## BY PROFESSIONAL DEMAND

DDC OFFERS FREE ADVICE, PERSONAL SERVICE AND ONE-DAY SHIPPING OF THE FINEST MUSIC AND SOUND EQUIPMENT AVAILABLE ANYWHERE:



PLEASE CALL OR WRITE FOR PRICES & ORDERING INFORMATION - YOU'LL BE GLAD YOU DID!

**DDC** DICKSTEIN DISTRIBUTING COMPANY  
1120 QUINCY PPKY-SCRANTON, PA 18510  
PHONE ORDERS WELCOME (717) 344 7469

## Vangelis

continued from page 24  
play it my way. This album was one of the most popular albums in Greece. It has nothing to do with the conventional way. These songs are exactly the same. The feel is exactly the same, but the way of expression is different. You can't say that it's ethnic music anymore. So maybe the synthesizer brings a more universal expres-

**JD:** Why do you use so many different makes of keyboards? Why don't you have just a couple of Prophet 10s or Yamahas?

**VP:** Each make is different and they give you different possibilities.

**JD:** Is it like a pianist, who thinks that each piano is different?

**VP:** Oh yes. Each synthesizer is different. Even if you have two of the same model you'll find that there's a difference between them. The more you know an instrument,

**"Each synthesizer is different. Even if you have two of the same model you'll find that there's a difference between them."**

the better it is. I think it's essential to have different ones.

**JD:** I see that you have a few different percussion devices.

**VP:** Yes, I have three different ways to produce percussion.

**JD:** What do you think of the Linn Drum Machine?

**VP:** It was the first one of that kind of thing. I think it's a little bit primitive, but it's okay.

**JD:** In the other room you have a whole arsenal of conventional percussion...

**VP:** Yes, but I have all that conventional percussion here (points to his Emulator). It's easier when you play. It all comes up on the keyboard chromatically and then I can change it.

**JD:** You've got an acoustic piano over there. Why wouldn't you just record it and throw it on the Emulator?

**VP:** That's possible, but the keyboard is bigger there. I've got more octaves. And the Emulator is not only to reproduce the sounds, but to change the sounds. You can do incredible things with it.

**JD:** What kind of mood do you have here when you record? Do you have all these people running around?

**VP:** It depends on when it comes. When it comes I have to do it. It depends on what mood I'm in.

**JD:** Do you still occasionally whip it out on the tympani?

**VP:** Oh yeah! There are still things that you can do on regular instruments that you can't do on the synthesizer.

(This interview is taken from a radio series called "Totally Wired: Artists in Electronic Sound". This is a series of 26 half-hour radio programs focussing on the history and artists of electronic music. The series will be distributed via National Public Radio's Extended Program Service and the National Federation of Community Broadcasters Distribution Service this summer. The series is produced by John Diliberto and Kimberly Haas and is supported by grants from Sequential Circuits, Inc., Yamaha Corporation, the Pennsylvania Humanities Council, and the Pennsylvania Council on the Arts.)

# MIDI

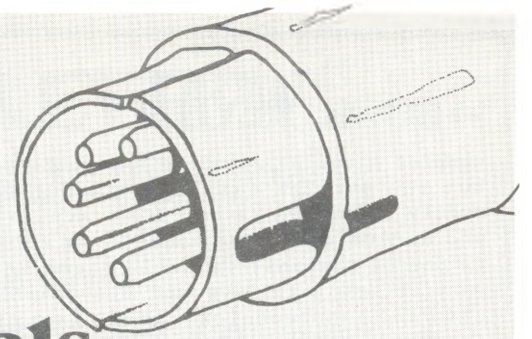

## Hardware Fundamentals

By: Stanley Junglieb

Sequential Circuits, Inc.

The Musical Instrument Digital Interface (MIDI) specification, recently worked out as a cooperative effort by several synthesizer manufacturers, enables the easy integration of devices (synthesizers, other electronic keyboards, sequencers, drum boxes, and home computers) made by various manufacturers into one programmable system. In being made compatible with foreseeable microcomputer technology, the useful lifetime of the musician's equipment is thereby multiplied. Also, the realization of complex electronic-assisted music, hitherto reserved for well-financed professionals, becomes more widely available (see the accompanying article by Jim Wright for details on what this electronic assistance means to musicians -- Ed.).

**Hardware.** To simplify cabling between instruments, the interface is serial. It operates at 31.25 kBaud (thousand-bits-per-second), asynchronous. This is considered a high speed for serial operation -- in comparison to the typical RS-232 maximum of 19.2 kBaud -- and was chosen to prevent objectionable delays between equipment. The 31.25 kHz clock can also be easily obtained from hardware, for example, by dividing 1 MHz by 32. One serial data byte consists of a start bit, 8 data bits (D0 to D7), and a stop bit -- for a total of 10 bits transferred in 320 microseconds (us).

Physically, MIDI appears as two or three jacks on the instrument. See figure 1, the hardware schematic. The connectors are DIN 5-pin (180 degree) female panel mount receptacles (Switchcraft 57GB5F or equivalent). DIN connectors were agreed to by U.S. manufacturers because it was felt that DIN connectors are now widely available here. However, the specification does provide that a manufacturer can use XLR connectors, if the firm makes available all necessary conversion cables.

The two required jacks are MIDI OUT and MIDI IN. The transmitter data typically originates in the instrument's UART. The interface circuit is a 5-mA current loop, designed especially to prevent the formation of audio ground loops which often develop in complex systems. The output is normally meant to drive only one input. If transmit data is low (0), current flows from Vcc (+5V) through Ra, over pin 4 of both connectors, through the opto-isolator, returns over pin 5, then through Rc. The

opto-isolator output is normally pulled high by Rd. However when current flows through the internal LED, the isolator output switch turns on, grounding Vo, thus sending a low to the receiver UART. When data is high, the LED does not light. The receiver UART therefore sees a high. D1 protects the opto-isolator from reverse-polarity currents which may result from transmitter anomalies.

Interconnect cables should not exceed 50 feet (15 meters), and must have a corresponding 5-pin DIN male plug (Switchcraft 05GM5M or equivalent). The cable should be shielded twisted pair, with the shield connected to pin 2 at both ends. Notice that while the MIDI OUT jack is grounded to the instrument chassis, MIDI IN is not. This allows the cables to provide their shielding services without creating ground loops.

The optional third jack, MIDI THRU, provides a direct copy of data coming in MIDI IN. It is included when the manufacturer intends the instrument to operate in a "chain" or "loop" network, as opposed to a "star" network. This question provides a convenient segue into the topics of modes and channels.

**Modes and channels.** The first point to realize about MIDI is that the total control features available still depend on the design of each specific piece of equipment. MIDI does not magically transcend equipment limitations or differences. Rather, it merely enables them to "communicate" at their "least common" level. For example, specific programmed sounds can't be transferred directly between different models of synthesizers because of inherent design differences, but keyboard information and program selections can be communicated.

One of MIDI's design goals was to be simple enough so that you could connect any polyphonic synthesizer to any other, or to a sequencer, and at the very least the notes would be correctly played or stored. This would be possible with virtually no other action on the part of the user. Above this minimum, each instrument may or may not include further facilities for complex control options.

Each type of equipment has different minimum requirements. For synthesizers, minimum usefulness seems to include remote keyboard control and program switching. While polyphonic sequencers send and



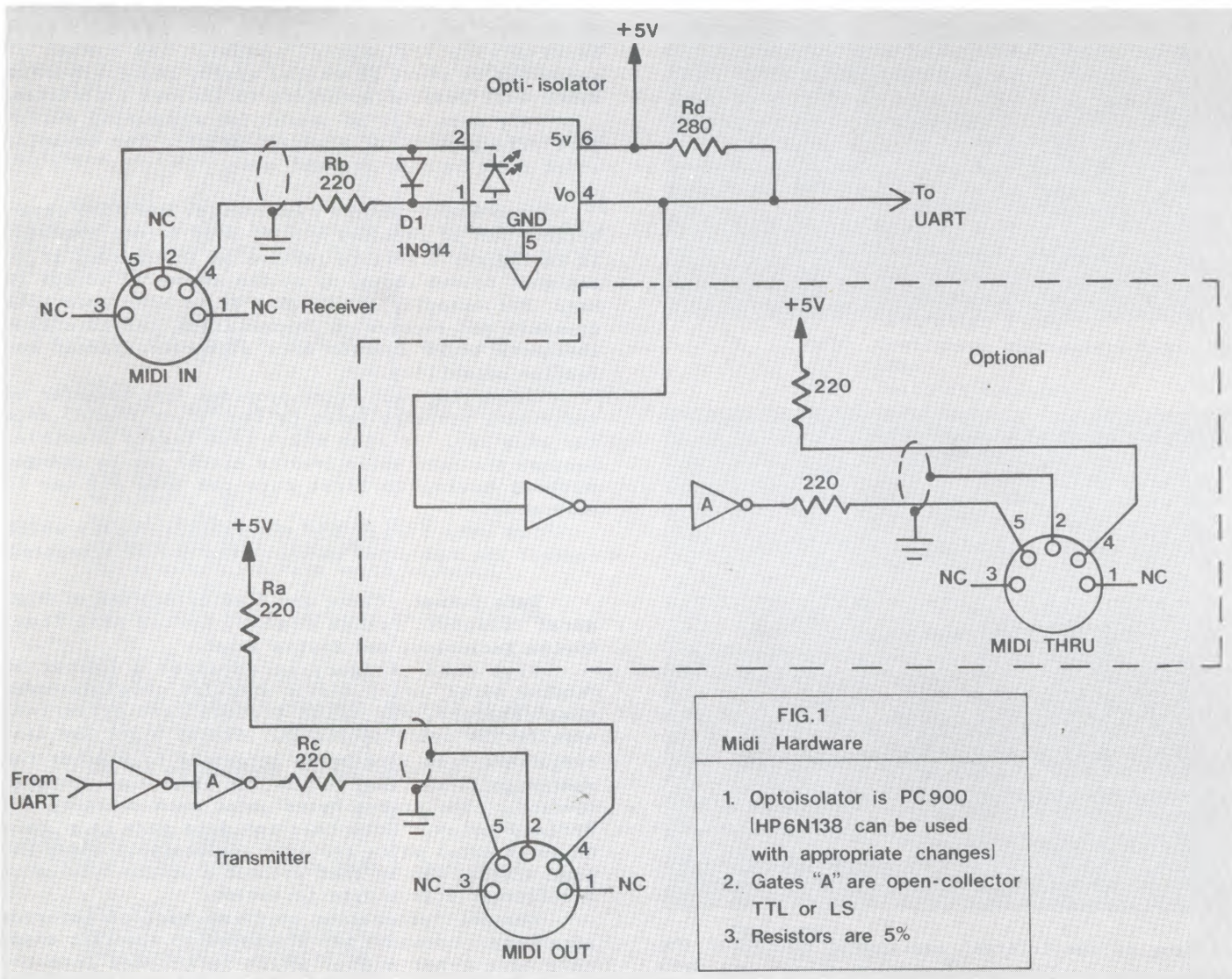

receive keyboard data, they may or may not be interested in program changes. Monophonic sequencers can only deal with individual lines, so keyboard data must somehow be different for them. Drum units don't usually care about specific keyboard notes, but may need to synchronize to their timing, or to the sequencer, and perhaps react to program changes as well.

While most of these requirements and useful control options can be foreseen, the number of possible interconnections cannot. Therefore while the specification says that each transmitter will drive one and only one receiver, provision has been made so that any specific instrument or synthesizer voice on the MIDI bus can be addressed, regardless of the interconnection scheme. This is accomplished by assigning up to 16 channels under increasingly powerful (and complex) modes.

Each unit connected to the MIDI bus has separate transmit and receive ports. There are three modes of operation for transmitters and receivers: Omni, Poly, and Mono. Omni mode is the most general level of operation, interfacing to all units. Poly mode allows each unit (synth, sequencer, or drum box) to be addressed separately. Mono mode is the most specialized, allowing individual addressing of (for example) each synthesizer voice.

Normally, transmitters will periodically send out a Mode Select command for the most powerful mode to which they can be configured. However, the actual data transmitted will be in the mode to which a second transmitter may have switched the receiver. For example, Synth A by default transmits in Omni mode to Synth B. Synth B, being capable of Poly mode operation, periodically transmits Poly Mode Select codes to Synth C. But the data sent from Synth B to C will be in Omni format (because Synth B's receiver is constantly getting Omni Mode Select commands from Synth A). Synth C may or may not respond to the Poly Mode Select commands from Synth B, because if a receiver is capable of operating in the requested mode, it switches to that mode. Otherwise it ignores the Mode Select command. (By the way, the Mode Select commands double as "All Notes Off" commands, therefore can only be sent while all notes are off, or when it is desired to turn all notes off.)

**Omni mode.** At power up or reset, all instruments default to Omni mode. See figures 2 and 3. Regardless of the system configuration, Omni transmitters always send polyphonic data on Channel 1. Omni receivers respond to Note On/Off Events sent over any channel (1-16). These notes are handled



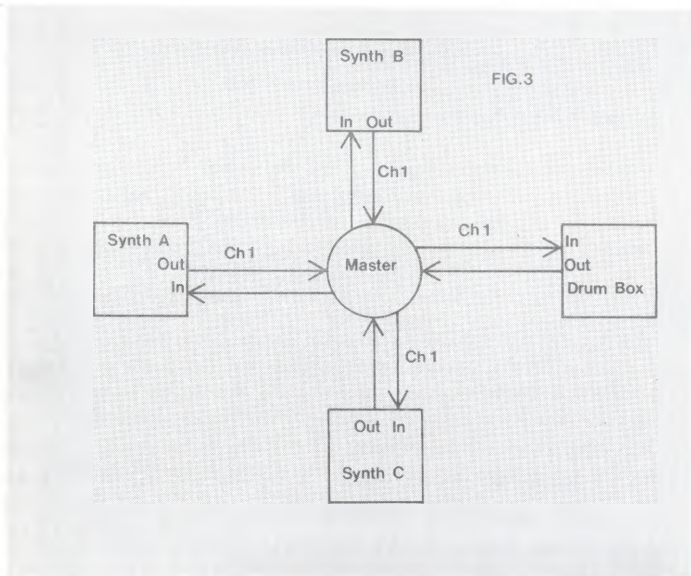
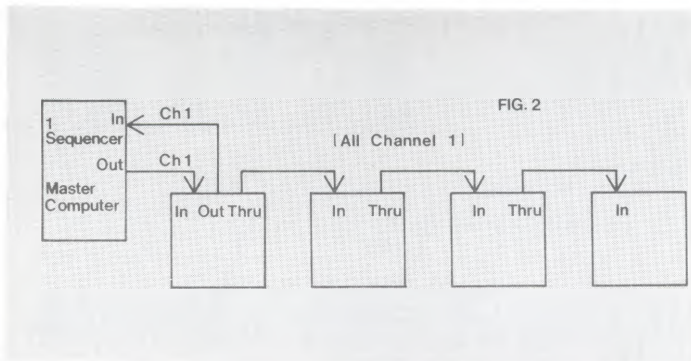

receiver on that channel to switch to Poly mode. Thereafter, the receiver listens for keyboard data encoded with its channel number. Any number of notes can be sent, to which, again, the polyphonic synth will respond according to its own priorities.

Poly mode will be useful for sequencing multi-part arrangements of standard synths, for example, which can't be done in Omni mode.

**Mono mode.** When a synthesizer has Mono capability, and it receives a Mono Mode Select command, it configures itself to receive on the channel it is assigned to and above, up to the number of voices it has. For example, the Prophet-T8 in Mono mode will transmit and receive on Channels 1-8. (Future synthesizers could contain more elaborate channel selection capability.)

Channeling each voice provides fast transfer of individual pressure (also called "after touch") data for each key. It also makes true *legato* possible, because the note value (=voice pitch) can be changed without having to first turn the note off (as in Poly mode).

The data format for the specific codes which control the modes and channels can now be presented.

**Data format.** There are five categories of MIDI data: Channel, System Common, System Real Time, System Exclusive, and System Reset.

Each data category encompasses a number of "status bytes" which define specific commands under that category, and which precede data bytes that specify the exact operation. Status bytes are distinguished from data bytes according to whether the most-significant (MS) bit is set (1=status) or reset (0=data). The status bytes under each category are defined below. Note that any data sets (e.g. Note On event data) which are sent successively under the same status, can be sent without a status byte until a different status byte is needed.

Channel information performs most of the routine work. Commands are addressed to specific channels by a 4-bit number which is encoded into the status byte. The associated data bytes can identify keys going down (on) and up (off), their on or off velocities, and pressure or "after-touch" (on keyboards so equipped).

System Common, Real Time, and Reset information is intended for all channels in a system. System Common information identifies song selections and measure numbers for all units. Real Time information is used for synchronizing everything (perhaps to a master sequencer). Therefore, Channel and System Common information is interruptible by System Real Time information.

according to the internal assignment scheme of the synthesizer. So this configuration allows any number of polyphonic synthesizers to play in parallel, as soon as they are interconnected.

A receiver's mode can only be changed by a Mode Select command transmitted in the channel(s) to which it is currently assigned. If the receiver is not capable of operating in the requested mode, it ignores the Mode Select command. No unit may switch its own modes. Even though a receiver in Omni mode receives in all channels, it will respond to Mode Select commands in only one channel: the one to which it is assigned.

Receivers and transmitters without channel selection capability are always assigned by default to Channel 1.

**Poly mode.** Omni mode addresses all units with the same data. Poly mode allows individual addressing of each unit. In other words, the master controller can send separate parts to each synth, whereas in Omni mode they all played the same part.

As shown in figure 4, the master controller in the chained network sends all commands, which are encoded with their destination channel number, over one line. This requires that each unit include an address selector switch to define its channel of operation.

The channel definitions having been made, the master controller must issue the command to the

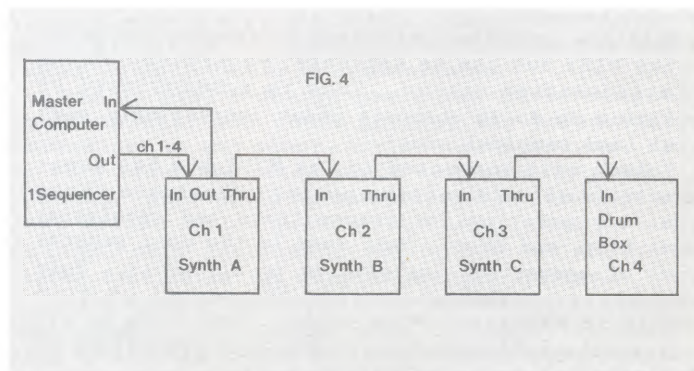



System Exclusive information allows the exchange of data which can be formatted as the manufacturer wishes. Only devices which recognize the manufacturer's format will attend the exchange.

Reset simply initializes all equipment to power-on condition.

The five categories are ordered below according to their utility.

**Channel.** The most significant four bits of each Channel status byte define the command, while the least significant four bits identify the effective channel.

9xH NOTE ON EVENT

3 bytes: 1001 nnnn + 0kkk kkkk + 0vvv vvvv

nnnn

Channel code, 0-15. Corresponds to channel numbers 1-16.

kkk kkkk

Key number, 0-127

For all keyboards, middle C=60. All C key numbers are multiples of 12.

The standard 5-octave synth keyboard ranges 36-96.

The 88-note piano keyboard ranges 21-108.

vvv vvvv

Key On velocity, 0-127

With no velocity sensors, default to 64.

With velocity, 1=ppp (softest), 127=fff (loudest)

Key On velocity=0, turns note off.

resolution is needed, then both are sent, first the MSB, then the LSB. If only the LSB has changed in value, the LSB may be sent without re-sending the MSB.

- 0 Pitch bender MSB
  - 1 Controller 1 MSB
  - 2 Controller 2 MSB
  - 3 Controller 3 MSB
  - 4-31 Continuous controllers 4-31 MSB
  - 32 Pitch bender LSB
  - 33 Controller 1 LSB
  - 34 Controller 2 LSB
  - 35 Controller 3 LSB
  - 36-63 Continuous controllers 4-31 LSB
  - 64-95 Switches (on/off)
  - 96-123 Undefined
  - 124 Local/Remote Keyboard Control (toggle)
  - 125 Omni Mode Select/All notes off
  - 126 Mono Mode Select/All notes off
  - 127 Poly Mode Select/All notes off
- If c=125, 126, or 127, v (see below) must be 0.

vvv vvvv

Control value, 0-127

For mode selections (c=125, 126, or 127), vvv vvvv must be 0.

Pitch benders should range from 0-127, with 64 being center (no pitch bend).

Other controllers will range from 0=minimum to 127=maximum.

Switches are defined as 0=off, 127=on.

8xH NOTE OFF EVENT

3 bytes: 1000 nnnn + 0kkk kkkk + 0vvv vvvv

vvv vvvv

Key Off (release) velocity.

Implemented on Prophet-T8.

CxH PROGRAM CHANGE

2 bytes: 1100nnnn + 0ppp pppp

PPP PPPP

Program number, 0-127

AxH POLYPHONIC KEY PRESSURE

3 bytes: 1010 nnnn + 0kkk kkkk + 0vvv vvvv

vvv vvvv

Pressure/After-touch value, 0-127

Used in Omni mode. (Compare code dxH, Mono mode)

DxH CHANNEL PRESSURE

2 bytes: 1101nnnn + 0vvv vvvv

vvv vvvv

Channel pressure/after-touch amount, 0-127.

For Mono mode: channel (rather than key) is identified.

BxH CONTROL CHANGE

3 bytes: 1011 nnnn + 0ccc cccc + 0vvv vvvv

ccc cccc

Control address, 0-127.

Except for the Pitch Bender (0), the controllers are not specifically defined. A manufacturer can assign the logical controllers to physical ones as necessary. The controller allocation table must be provided in the user's operation manual. Continuous controllers (including the Pitch Bender) are divided into Most and Least Significant Bytes. If only 7 bits of resolution are needed for a specific controller, only the MSB is sent. It is not necessary to send the LSB. If more

ExH UNDEFINED

(SCI uses this status for Pitch Wheel change in the Prophet-600. For further information, see the Prophet-600 MIDI specification.)

**System Exclusive.** A format has been defined for System Exclusive information, consisting of a two-byte preamble, the data itself, and a one-byte end code. The purpose of this format is to provide for the transmission of data which may be useful to any two instruments from one manufacturer but uninterpretable to other MIDI-bussed devices. For example, SCI uses this protocol for loading and dumping program data. System Exclusive information can only be interrupted by a System Reset command.

Format: FOH + 0iii iii + data + F7H

F0H

Status byte. Must be followed by manufacturer's ID#.

0iii iiii

Manufacturer's ID#.

iii iiii can be 0-127

Current ID numbers are:

- Sequential Circuits 01H
- Kawai 40H
- Roland 41H
- Korg 42H
- Yamaha 43H

Receivers which do not recognize the ID# ignore the ensuing system exclusive data.

data

Any number of bytes.

MSB must be reset. (Otherwise will signal a new status byte.) Data can range 0-127.

Data is intended for all channels.

F7H

An END-OF-BLOCK code which terminates System Exclusive status.

SYSTEM RESET will also terminate System Exclusive status.

In no case should other data or status codes be interleaved with System Exclusive data, regardless of whether or not the ID code is recognized.

Under "data", SCI uses the following protocol to code program transfers (see also the MIDI specification for each instrument):

Byte 3	Byte 4		
00H	PP	F7H	PROGRAM SEND REQUEST
01H	PP	dd...dd	F7H Prophet-5 programs
02H	PP	dd...dd	F7H Prophet-600
03H	PP	dd...dd	F7H Prophet-T8
04H	PP	dd...dd	F7H Prophet-10

PP=program number  
dd=data in 4-bit nibbles, LS nibble first, right justified.

**System Real Time.** The System Real Time codes control the entire system in real time. They are used for synchronizing sequencers and rhythm units.

To maintain timing precision, these codes can be sent between any System Common or Channel data sets which consist of two or more bytes. However, the codes may not be interleaved with System Exclusive data.

System Real Time statuses are intended for all channels and recognized by all units using the interface. If the functions specified are not implemented, they are simply ignored.

F8H TIMING-CLOCK-IN-PLAY

This clock is sent while the transmitter is in Play mode. The system is synchronized with this clock which is sent at a rate of 24 clocks/quarter note.

F9H MEASURE-END

The MEASURE-END is transmitted instead of the TIMING-CLOCK-IN-PLAY at the end of each measure.

FAH START-FROM-1ST MEASURE

This code is immediately sent when the PLAY button on the master (e.g. sequencer or rhythm unit) is hit. The first TIMING-CLOCK-IN-PLAY must follow within 5 ms after this code.

FBH CONTINUE START

This is sent when the CONTINUE button (on the master) is hit. A sequence will restart from the point where the sequence stopped on the last TIMING-CLOCK-IN-PLAY. The next TIMING-CLOCK-IN-PLAY must be sent within 5 ms after this code.

FC TIMING-CLOCK-IN-STOP

This code is clocked in Stop mode, to synchronize a Phase-Locked Loop (PLL) which is used (during Stop) for interpolating the timing clock.

**System Common.** System Common information is intended for all channels in a system.

F1H Undefined

F2H MEASURE INFORMATION

3 bytes: F2H + 0mmmm mmmmm (MS) + 0mmmm mmmmm (LS)  
The two data bytes code the 14-bit measure number.

F3H SONG SELECT

2 bytes: F3H + 0sss ssss  
The data byte codes the 7-bit song number.

F4H Undefined

F5H Undefined

F6H TUNE REQUEST

Initiates synthesizer tune routines.

**System Reset.** There is one system reset code. It initializes the entire system to the condition of just having power switched on.

FFH SYSTEM RESET

System Reset should be used sparingly, preferably under manual command only. In particular, it should not be sent automatically on power up. This could cause two units connected together to endlessly reset each other.

**Conclusion.** This concludes this introduction to the MIDI specification. MIDI really does present some astounding new opportunities for electronic musicians. It should stimulate those whose enthusiasm may have waned because of the general incompatibilities and rapid obsolescence of equipment manufactured over the past few years.



# MXR OMNI EFFECTS SYSTEM A REVIEW

By: Peter Montgomery

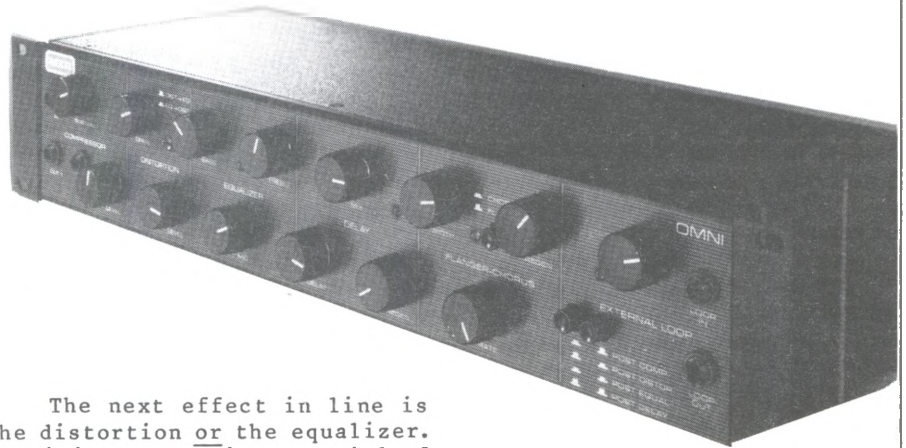

The Omni is a double-width rackmount device which includes, in series connection, a compressor (with sustain and level controls), distortion (drive and level), equalizer (bass, treble, and mid-range), delay line (mix, delay, and regeneration), flanger/chorus (width, rate, and regeneration), and external effects loop. There is also a master level control for the whole unit, and LED indicator for each effect to show if it is in the signal chain or not.

A footswitch box controls which effects are in and which are out, and also includes LEDs to let you know an effect's status. Through a very clever switching technique, the cable connecting the footswitch box to the rackmount housing is not some multipin custom connector which can only be ordered from MXR; instead, you use a stock, two conductor cable with 1/4" phone plugs -- either your own, or the 12' long cable supplied with the unit. The cable doesn't even have to be shielded, and you can do things like shorting the switching cable's hot conductor to ground without the unit blowing up or even caring.

A master bypass switch removes all effects from the signal path, and any panel LEDs which were on to indicate an effect being in change to half-brightness. Theoretically, this means that between songs, you can press the master bypass switch and reprogram which effects are in or not, with the LEDs confirming the effect's status. In practice, the half and full brightness aren't that different, and I feel bi-color LEDs would be much better. Since the footswitch box (which would probably be closer to the musician than the rack housing) also has status LEDs, the problem isn't as bad; but bi-color panel LEDs would be better.

**The individual effects.** All the effects in the system are well designed, low noise units which perform well. First, the Omni's compressor has been designed so that the amount of compression goes from unnoticeable to heavy duty, zero dynamic range compression. It is quiet throughout most of the sustain control's rotation, but like all compressors, becomes somewhat noisy with full sustain. Since I like my compression on the subtle side, this was no problem.

The next effect in line is the distortion or the equalizer. Realizing the sonic potential of EQ followed by distortion as well as the more traditional distortion followed by EQ, the Omni's designer chose not to hard wire one configuration over another. Instead, a front panel switch selects the sequence. I was very pleased to discover that the distortion unit was quite low noise, especially as distortion units go -- even when listening over studio monitors, instead of a typical guitar amp that rolls off at 6 kHz. If you punch in both the compressor and the distortion, then (not unexpectedly) the noise becomes noticeable. Also, if you like treble cranked to the max and bass rolled back, then you'll probably also notice the noise. Otherwise, I don't think the distortion will cause any hiss problems. My only complaint was that I couldn't get a rough sounding fuzz; for smooth, distorted chordal and lead work the Omni's fuzz is great, but for a rough sound I mostly used Craig's Tube Sound Fuzz circuit.

As for the equalizer, not much can be said other than that it is as good as any guitar amp three band equalizer. The amount of boost and cut is approximately +12 dB, and the frequencies were wisely chosen (bass = 150 Hz, mid = 1.3 kHz, hi = 2.7 kHz). I used the Omni for both bass and guitar parts, and had no problems getting

the EQ to give me a good sound. I didn't use it with keyboards, only because the Polysix I was using sounded fine without any equalization.

Next comes the delay line. This is a well designed and quiet delay which goes from 30 to 300 ms; enough delay to get the sounds I wanted. From what I could tell, the delay line uses both compansion and heavy filtering to keep noise down, since I didn't have any problems with hiss at all -- whether going for a slightly thickened sound or longer, runaway echoes. With short delay times and no regeneration, I was able to get a fat bass sound which sounded both great and natural...a neat trick! You really couldn't tell there was any signal processing going on until you punched the delay out, and then the signal sounded wimpy in comparison.

The flanger/chorus is the next device in line, and the one with which I was least pleased. My big complaint is that having only width, regeneration, and rate controls limits the available sounds. The flanging sound was good, but I would have liked initial delay and mix controls, and also the option of positive or negative feedback. While the chorus sound was okay, I could get neither as thick a sound, nor as ethereal a sound, as I would have

liked. Here, especially, an initial delay control would be very helpful. A mix control would also be nice since I often like to set up a chorus sound with a lot of LFO modulation on the delay line. This varies the pitch more than most people like, but then I mix it low as sort of an ambience sound. I think the main reason these extra controls were not included was because of space, but on the plus side, the flanger/chorus does do an adequate job, and it is quiet. Again, compansion and filtering is used to advantage here.

The last option in the Omni's signal path is an external loop. Aside from being useful, the loop is also (like much of the rest of the unit) very cleverly designed. Two front panel pushbuttons select where the loop gets inserted in the signal path; it can be post compression, post distortion, post EQ, etc. My only complaint about the loop is that the output level of the loop can't be user-adjusted. Since the loop is set up for commercial effects boxes (low level signals), any effects you might have that are set up for line level inputs will suffer in the signal-to-noise ratio department. While a preamp could be

added to feed line level units, it would be nice if this were an integral part of the unit.

There are some thoughtful "extras", such as synthesized stereo outputs, a direct output from the delay line, and all effects being the same phase. These also show a certain attention to detail.

**Conclusion.** All in all, I was very pleased with and very impressed by the MXR Omni. The designer was intelligent in both his choice and utilization of the effects in the system. When I first found out that the list price is \$725, I thought the price was a bit high. However, when you realize that you're getting five high quality effects that don't need batteries, the price becomes quite reasonable. Besides, \$725 is the list price, and like all things, the Omni sells for less in the stores. The system is especially good for someone who is gigging a lot because it organizes five effects into one easy-to-use package, and requires only one stock guitar cord to interface the footswitch box and mainframe. In my opinion, the Omni is well worth the price by virtue of its high quality and features.

## Letters

continued from page 32 to tell us that they would like a bit more description on projects. So, we'll try to cover things in a little more depth in those articles intended for beginner-to-medium level experimenters, although every time an article becomes longer, that leaves less space in the magazine for other articles. As always, we'll strive to strike a balance that keeps everyone happy.

As far as Casio mods, we called Jim Cooper; he does not at the present do any 202 mods. However, he does do some other interesting mods, such as a polysequencer for Z-80 based polysynths, poly synth memory expansion (for more patches), a way to let matrix-type keyboards control each other, etc.

### LYRICON, PLEASE!

I will be in New York during the last week in July and/or first week in August. The main reason for the trip is to purchase a Lyricon (the driver, Lyricon 2, or original Lyricon). However, I understand that the manufacturer, Computone, is out of business so the instruments are not easily available. If any readers from the New York area can help me locate a Lyricon -- used or new, as long as it's working -- please contact me at the address below and include your telephone number.

Raphael Walrond  
2 Store Street  
Mon Repos, San Fernando  
Trinidad, West Indies

### GUITAR SYNTH INFO NEEDED

I am attempting to design a hexaphonic guitar synth, however I have not been able to find 1) a commercially available hex pickup or 2) any stable and practical interface circuitry (P/V conversion, trigger, gate, etc.) published anywhere. Can anyone help?

Gordon Currie Jr.  
2947 72nd SE  
Mercer Island, WA 98040

I'm writing to (Craig Anderson) to beg you to design a new gadget that converts a guitar signal to a 1V/octave voltage trigger. Also, I was very happy to see the Rocktave Divider in the April Guitar Player. I built one

continued on page 42

# LARSEN Music Co.

We can supply you  
with equipment that gives  
meaning to the word

## PERFORMANCE

Roland &

YAMAHA

synthesizers are just part  
of a complete line of  
keyboard equipment  
we offer to the  
discriminating  
musician.

4001 N.W. 63rd STREET - P.O. BOX 32006  
OKLAHOMA CITY, OKLAHOMA 73123  
405-843-1573



Attention all musicians with lean wallets: I think Korg's new Poly 61 is the best dual oscillator, 6 note polyphonic keyboard for the money. It features two digitally controlled oscillators (DCOs) per note, chord memory, variable octave arpeggiator, programmable release pedal, and 64 programs with parameter editing for a list price of \$1,495. But, Polysix fans, don't go out and sell your instruments because of this new product; there is a considerable difference in the sound of both instruments. The Polysix gets its sound from the analog oscillator that is signal processed with analog delay lines, but the new Poly 61 gets its characteristic sound because it has two digitally controlled oscillators and no delay line processing. The Poly 61 has a cleaner sound (crank up the output control, and you hear nothing) because of the DCOs, and the Polysix sound has more of an "edge". The strings on the Polysix sometimes sound fuller because of the chorus effect available with the on-board delay, but the strings on the Poly 61 sound, in certain presets, more human. I like the strings on the 61; although digitally generated strings can have a rather "clinical" and robotic sound, listen to some of the presets on the 61 (i.e. 42, 43, and 44), and you will like them.

The Poly 61 is a state of the art, "electronic-nouveau" looking product. Instead of scores of potentiometers and faders, the 61 has a few pushbuttons and knobs. It looks quite slick, with a neatly silk-screened "crib sheet" for editing parameter values, three prominent LED displays, and uncluttered cosmetics...the complete antithesis of its multiple control predecessor, the Polysix. Whereas the Polysix was easily edited with the tweak of a knob (thereby allowing parameter dynamics), the Poly 61 uses a more involved system. For example, here is the procedure for editing a program (say, preset 16, funk bass):

1. Press buttons 1 and 6 on Program Mode.
2. Press the Parameter button to gain editing control.
3. Screened, pre-printed values on the front panel tell you what number to call up to alter what parameter. Look this over and decide what particular parameter you want to change; for example, to change the cutoff frequency, you call up parameter #31.

# Applied Synthesis:



## Poly-61 Review

By Bill Rhodes

4. After selecting parameter #31, you may change its value anywhere from 0 to 63 (thereby altering the cutoff frequency) by using either the "up" or "down" pushbuttons. These select the number corresponding to the desired cutoff frequency.

5. To change another parameter (say, octave registration, which is preset #11), call up #11 and change the value (footage) using the up and down buttons. Note that all parameter value edits are cumulative (add on from one to another).

This is a different process from the Polysix and might be suited for particular needs of particular individuals.

**The Sounds.** I might get into trouble, but the Poly 61's sound reminds me of the new Memorymoog. Preset #11 is a Gino Vanelli-ish brass ensemble sound with the balls of the Moog machine. The Rhodes sound (vibes/synthi-piano #14) is very quiet and incorporates LFO tremolo in its sound. The flutes (preset #17) are quite realistic and not noisy. As you may be aware, pure waveforms (triangle, sine, etc.) tend to show up noise since there is little high frequency content to mask hiss. However, DCOs are inherently quiet, so noise is seldom (if ever) a problem. The organ sounds (of which there are many) are great sounding reproductions with some presets incorporating the key-click sonorities we all know and love. I could go on describing the presets for days...but a better alternative is for you to go to your local music store and check them out. In my opinion, 70% to 80% are useful. Preset #18 (helicopter!) is good, I guess, if you want to do the soundtrack to Apocalypse Now II. I especially liked the tuned 5th trumpets in preset #21 and solo violin in #46. On the Poly 61, Korg has changed the modulation and pitch wheels included in the Polysix to a single joystick that is spring loaded

and returns to center. The top quadrant of the joystick controls DCO modulation, left and right control pitch, and the lower quadrant modulates the VCF.

As with the Polysix, the arpeggiator on the 61 has memory latch, up, down, up-down, and octave registration functions. There is also chord memory for playing up to six notes (at different intervals) for "ope-finger" chords. There is no readily available unison mode.

There are 64 factory loaded programs which can be stored (dumped) on cassette, as can your own programs. You may also load programs from cassette.

On the back of the 61 there are hi/lo inputs and outputs for a programming interface, a write and load enable/disable switch, a program up input, headphone output, hi/lo main output, release pedal output, trig in input (for external sync from another clock, rhythm unit, etc.), and cord cleats. The instrument weighs practically nothing. It is sleek and low. It covers five octaves. It is computer looking. It sounds great, it's quiet, and I love it.

Another thing I must mention: I have been doing demos and clinics for Korg for some time now. I have used this instrument profusely and the comments from all listeners are the same: "fantastic", "can't believe the price", "best digital strings for the money", "Keith should get rid of his B-3", etc. I will not praise a product because I work as a clinician for a particular company. I have worked for many keyboard companies for years, and I will tell you (and them) whether a product is garbage or not. The Poly 61 is the most cost-effective keyboard I've seen in quite a while. And, it only lists for \$1,495! ●

Next time: Everything you wanted to know about modulation but were afraid to grasp.

# EQUIPMENT EXCHANGE

classified rates for individuals offering goods or services for sale or trade: 25c per word, 20 word (\$5.00) minimum charge; Commercial establishments: 50c per word. Prices, zip, phone numbers count as one word each. **DISPLAY CLASSIFIED: \$15.00 per inch, one inch minimum, camera ready art to be supplied by advertiser.** All classified advertising must be prepaid. Advertisers using a post office Box number for responses must furnish Polyphony Publishing Co. with a complete street address and phone number. Readers should respond directly to advertiser. Polyphony is not responsible for claims made in ads, or for the results of any transactions. Polyphony reserves the right to edit or refuse any ads submitted.

## SALE

### FLOOR MODELS/DEMONSTRATORS

All items carry a full factory warranty.

**MEMORYMOOGs:** Two units, virtually flawless, \$2300 ea.

**POLYMOOG w/ Legs:** Good condition, fully calibrated & tested, \$1750.

**POLYPEDAL:** For use w/ above, a hard-to-find item. Reconditioned floor model, \$250.

**Moog SOURCE:** Perfect condition, \$695.

**Moog TAURUS II Bass Pedals - Controller Only:** Interface w/ most any synthesizer. Excellent condition, \$375.

**Moog ROGUES:** Two units, excellent condition, \$305 ea.

**SOUNDCHASER II:** w/ standard & Turbo Traks software, Demo Disk. Excellent condition, diskettes & manual are new, \$1150.

**ELECTRO-HARMONIX 16 SECOND DIGITAL DELAY:** Good condition, tough sounds, incredible value, \$395.

### OTHER MERCHANDISE

**MINIMOOGs, SPECIAL EDITION:** Two of the last 25 Minis produced - w/ updated oscillator cards, rear-panel interface, back-lighted clear lucite wheels, hand-rubbed finish, brass identification plaque. More than collector's items, these are the most fat-sounding synthesizers ever made, period. Both are factory-new with full warranties, \$1995 ea. (Shipping included).

**Moog PRODIGYS:** Brand new, last in U. S., full warranties, \$495; \$549 w/ interface.

**Rhodes CHROMA:** Call or write.

**360 SYSTEMS DIGITAL KEYBOARD:** Call or write.

**CASIO KEYBOARDS:** Call or write.

### SHIPPING

**MEMORYMOOG, POLYMOOG, & CHROMA** are shipped via Motor Freight, shipping charges collect. Other items are shipped via UPS surface - we pay UPS charges on orders prepaid by Cashier's Check or Money Order.

### SERVICE

**Musitech™** is a factory-authorized Moog Service Center. We service what we sell. We do custom mods.

## Musitech™

1631-A East 25th Street  
P.O. Box 3717  
Chattanooga, TN 37404  
(615) 624-5600

## Music equipment

**FOR SALE:** one PAIA Stringz 'n' Thingz, one PAIA Organtua. each cost \$299.00 in kit form. I'll sell you mine assembled and tested for \$250 each. Call (405) 521-9673 and ask for Greer.

**FOR SALE:** E-mu modular synthesizer system; 28 modules; 5 VCO, 4 VCF, 6 VCA, 6 TG, Sequencer, more. 5 octave keyboard, 2 mahogany cabinets, extras. Originally over \$11,000, asking \$3,850. Call (607) 829-6248.

**PAIA 2720-R Modular synthesizer** \$225, **OZ/Gnome combination** \$125, **Quadra Sound blnder with Reverb and vibrato** \$50, Asking prices listed, will consider any reasonable offer. **FREE SHIPPING!** Call or write Alan Skidmore, Rt. 7, Box 184, South Charleston, WV 25309 (304) 768-8797 or (304) 442-5397.

**PAIA 8785 Linear DAC** \$15, **8782 encoded keyboard in road case** \$100, **8781 Quash #20, (2) 4761 Road cabinets** \$25, **4711 mixer** \$15, **4712 Reverb** \$15. **Dave Biddle, 1275 Smith S.W., Canton, OH 44706 (216) 452-6367.**

**LASER-SYNTHESIS:** All working well, some pro. mods, Seq-circuits: Sequencer 800 \$475, Programmer \$575. Synare II \$575 Crumar: Orchestrator Plus \$800, Pedal-Bass Plus \$300. ARP: Omni \$575, 2600-2V \$1200, Sequencer \$450. Complete list with lasers: \$1 + SASE. Omega 3284 80th Avenue S½E½, Mercer island, WA 98040 (206) 232-6256.

## Wanted

8700 - will buy it assembled or not, with or without bugs. \$130 or best offer. Paul Schilling, 1718 Camelot drive, madison, WI 53705

# Letters

continued from page 40  
within 48 hours of receiving the issue. It works great! One suggestion, though. I found that a mix pot between straight and 8va signals really helps the definition of the sound. Thanks!

Craig Martin Smith  
Newark, DE

Gordon and Craig -- Electro-notes (1 Pheasant Lane, Ithaca, NY 14850) published some guitar P/V circuits a few years back. Write them direct for information on reprints of articles concerning guitar synthesizers.

As far as hex pickups are concerned, Bartolini Pickups (2055 Research Drive, Livermore, CA 94550) makes a hex pickup. You might also be able to obtain a GR-series replacement pickup from Roland, and adapt it to your guitar.

Those of you who have successfully created hex guitar systems are invited to write in to Polyphony and describe your work. Finally, you can always buy a Roland GR-series guitar, and build your own custom system around it...something which I've been considering doing, but have not been able to implement due to time limitations.

## AD INDEX

Dickstein Distributing Co. ...	33
Gentle Electric .....	29
Larson Music .....	40
Macrofusion Computer Music ...	2
PAIA Electronics, Inc. ....	40,44
PGS Electronics .....	43
Polymart .....	26,27,28
Telex .....	15



### LINEARS

TL061.....BiFet.....	.72
TL062.....Dual BiFet.....	.99
TL064.....Quad BiFet.....	1.95
TL071.....BiFet.....	.65
TL072.....Dual BiFet.....	1.15
TL074.....Quad BiFet.....	1.95
NE555.....Timer.....	.39
NE570.....Compannder.....	3.80
NE571.....Compannder.....	2.95
NE572.....Compannder.....	4.95
UA741.....Comp. OpAmp.....	.29
MC1456.....Low Noise OpAmp.....	.90
RC1556.....Low Noise OpAmp.....	1.48
CA3080.....OTA.....	.94
CA3280.....Dual OTA.....	1.98
RC4136.....Quad OpAmp.....	1.10
RC4739.....Dual Low Noise.....	1.19
NE5532.....Dual High Perf.....	3.70
NE5534.....High Performance.....	2.65

### SPECIAL PURPOSE

SAD-1024.....Analog Delay.....	17.50
SAD-4096.....Analog Delay.....	37.50
MK50240.....Top Octave Div.....	5.95
SN76477.....Sound Generator.....	3.45

### SANYO HYBRID POWER AMPS

STK050.....50 Watt Power Amp.....	19.40
STK070.....70 Watt Power Amp.....	24.20

### SSM- SOLID STATE MICRO-TECHNOLOGY

SSM 2010.....VCA.....	7.50
SSM 2011.....PreAmp.....	5.75
SSM 2012.....VCA.....	9.50
SSM 2020.....VCA.....	7.50
SSM 2022.....VCA.....	7.50
SSM 2030.....VCO.....	7.50
SSM 2033.....VCO.....	10.00
SSM 2040.....VCF.....	7.50
SSM 2044.....VCF.....	7.50
SSM 2050.....VCTG.....	7.50
SSM 2056.....VCTG.....	5.75

### THERMISTER (Temp. Sensing Resistor)

TSR-Q81.....Tel Labs Q81 1k.....	\$3.50
----------------------------------	--------

### OPTO-ISOLATOR

CLM6000.....Clairex CLM6000.....	\$2.85
----------------------------------	--------

### CAPACITORS (25 volt)

701-100.....100 pf polystyrene.....	.25
701-180.....180 pf polystyrene.....	.25
701-1000.....1000 pf polystyrene.....	.25
701-2200.....2200 pf polystyrene.....	.25
701-2200.....3300 pf polystyrene.....	.25
701-3900.....3900 pf polystyrene.....	.25
702-005......005 uf mylar.....	.12
702-01......01 uf mylar.....	.12
702-05......05 uf mylar.....	.16
702-1......1 uf mylar.....	.21
702-22......22 uf mylar.....	.33
703-1.0.....1.0 uf tantalum.....	.39
703-3.3.....3.3 uf tantalum.....	.49
703-4.7.....4.7 uf tantalum.....	.59
704-2.2.....2.2 uf electrolytic.....	.21
704-4.7.....4.7 uf electrolytic.....	.21
704-10.....10 uf electrolytic.....	.21
704-100.....100 uf electrolytic.....	.31
705-10.....10 pf ceramic disk.....	.15
705-01......01 uf ceramic disk.....	.12
705-1......1 uf ceramic disk.....	.17

### IC SOCKETS (solder tail)

IC-S-08.....8 pin high quality socket.....	.27
IC-S-14.....14 pin high quality socket.....	.30
IC-S-16.....16 pin high quality socket.....	.34
IC-S-18.....18 pin high quality socket.....	.40
IC-S-28.....28 pin high quality socket.....	.60
IC-C-08.....8 pin economy socket.....	.13
IC-C-14.....14 pin economy socket.....	.15
IC-C-16.....16 pin economy socket.....	.17
IC-C-18.....18 pin economy socket.....	.20
IC-C-28.....28 pin economy socket.....	.40

### RESISTORS 5%, 1/4 watt

All EIA values available from 2.0 ohm to 5.1 Meg.  
Also available is 10 Meg.

100 each of same value.....	\$1.50
50 each of same value.....	.98
25 each of same value.....	.75
10 each of same value.....	.40
5 each of same value.....	.25

### ASSORTMENTS

10 each of 10 values (100).....	3.00
25 each of 10 values (250).....	6.50
50 each of 20 values (1000).....	16.00

### CHORUS/DELAY KIT

This chorus/delay unit, designed by Craig Anderton and featured in Guitar Player magazine, provides flanging, slapback echo, and automatic double tracking effects. The delay range is from 2 ms to 80 ms. Due to the use of compression and expansion techniques, the unit has dead-quiet operation up to about 50 ms and only minimal noise out the full 80 ms. This project kit consists of all electronics, pots, jacks, etc. Also included are the two circuit boards (etched, drilled, and legended) needed for the project. Not included is wire, solder, case, knobs, etc. The Chorus/Delay unit also needs a well regulated bi-polar 15 volt power supply (not included). (A punched and legended rack mount panel will soon be available for this project.)

Order KT-CD777..... \$78.00

### "SNARE + " DRUM VOICE KIT

This percussion synthesizer was designed by Thomas Henry and appeared in POLYPHONY magazine. Here's what Craig Anderton had to say about the "SNARE +". "At last - an inexpensive drum voice that has a punchy, full sound. ....All in all, the Snare + delivers a lot of drum sounds, and I would unhesitatingly recommend it to anybody who's tired of the thin sound found in most electronic drum units."

We offer the kit with or without a panel. Kit 3770 contains all electronic parts, switches, jacks, pots, etc, as well as etched, drilled, and legended circuit board. Kit 3772 includes all this plus a punched and legended rack mount panel (standard 1 3/4 by 19 inches) available in black or blue (both with white legends).

Not included with either kit is wire, solder, mounting hardware, etc. The SNARE + also needs a bi-polar 15 volt power supply (not supplied).

KIT 3770 Basic SNARE + kit..... \$33.95  
KIT 3772 SNARE + with rack panel... \$44.94

### THE "CLARIFIER" GUITAR EQ/PREAMP

The "CLARIFIER" is an onboard preamp/EQ module for guitar. This design, by Craig Anderton, was first seen in the pages of GUITAR PLAYER magazine. Here's what the CLARIFIER will do: Replace the guitar's standard passive tone control with a two control, active circuit which provides over 12 db of bass and treble boost and up to 6 db cut.... Buffer your pickups from external loading, giving additional output and improve high freq response.... Add a nominal 6 db of gain to give your signal a bit more punch, as well as improve the signal/noise ratio in multiple effects systems... make your guitar immune to the high freq loss caused by long cable runs.

The CLARIFIER kit is available in two options, both of which include a high quality drilled, legended, and masked circuit board, as well as complete step by step instructions. Kit 2450 contains everything needed for a complete unit... Kit 2455 contains everything except the pots (for those who prefer a particular brand of potentiometer). Batteries are not included with either kit.

KIT 2450.....Complete CLARIFIER kit . \$18.95  
KIT 2455.....CLARIFIER less controls ..\$14.95

**TERMS: (Check, Money Order, Cashiers Check - Add .75 if under \$10.00) - \$10.00 minimum on C.O.D. (UPS only) add \$1.50) - (Mastercard and Visa: \$10.00 minimum. You must supply exp. date.) - (Indiana residents add sales tax.)**

**SHIPPING AND HANDLING: \$1.00 plus 5% of purchase. We will credit any amount over our standard rate.**

**SATISFACTION GUARANTEED!**

### SIGNAL DIODE

601-60.....1N914 (1N4148) signal diode .	5/.35
--	-------

### TRANSISTORS

2N3904.....2N3904 NPN Transistor.....	.25
2N3906.....2N2906 PNP Transistor.....	.25

### POTENTIOMETERS

[3/8 long shaft, 5/16 mounting hole]	
854-401.....10K Linear taper.....	1.09
854-501.....100K Linear taper.....	1.09
854-505.....500K Linear taper.....	1.09
855-401.....10K Audio taper.....	1.09
855-501.....100K Audio taper.....	1.09
855-505.....500K Audio taper.....	1.09
856-401.....10K Audio taper with on/off switch.....	1.25

### TRIM POTS (vertical mount)

802-251.....250 ohm trimmer.....	.40
802-103.....10K trimmer.....	.40

### MINI TOGGLE SWITCHES

403-20.....SPDT (on/on) sub-mini (3A).....	1.20
403-40.....DPDT (on/on) sub-mini (3A).....	1.50
405-10.....SPST (on/off) sub handle (6A).....	1.85

### LED's

Please note that the typical DC forward current (I-fwd) of these LED's is less than those offered elsewhere making these LED's ideal for battery circuits or others where current consumption is a factor.

305-201.....Red T-1 1/4 jumbo diffused (20 ma).....	.30
305-202.....Green T-1 1/4 jumbo diffused (30 ma).....	.40
305-203.....Dual T-1 1/4 jumbo diffused (50 ma).....	.90
305-204.....Tri T-1 1/4 jumbo diffused (20 ma).....	1.50

Note: 305-204 is a three lead, tri-color (green, red, yellow) device. It is essentially two separate LED's in one package. (The yellow is obtained by turning on both green and yellow.)

### JACKS and PLUGS

1/4 In. PHONE JACKS	
901-101.....Mono standard phone jack.....	.45
901-103.....Mono with n/closed contact.....	.52
901-105.....Mono encl. jack (open back).....	.55
902-211.....Stereo standard phone jack.....	.70
902-213.....Stereo encl. jack (open back).....	.77

1/8 In. MINI JACKS	
903-351.....Mono with n/closed contact.....	.32
903-353.....Mono encl. (open back).....	.26
903-355.....Mono enclosed with contact.....	.35

RCA JACKS	
921-100.....RCA jack, chassis mount.....	.34
921-200.....RCA jack on phenolic mount.....	.25
921-300.....Dual RCA on phenolic mount.....	.43

1/4 In. PHONE PLUGS	
911-201.....Mono, black phone plug.....	.48
911-203.....Mono, red phone plug.....	.48
911-205.....Mono, chrome (metal) plug.....	1.20
911-211.....Stereo, black phone plug.....	.65

1/8 In. MINI PLUGS	
913-251.....Mono, black mini plug.....	.38
913-253.....Mono, red mini plug.....	.38
913-255.....Mono, chrome (metal) plug.....	.56

### SWITCHING JACKS

These are stereo phone jacks that contain an independent switching system that is controlled by the insertion of the plug. Jack 905-301 contains the equivalent of a DPST normally on switch. Jack 905-302 contains the equivalent of a DPDT on/on switch making it ideal for switching bi-polar power supplies on and off in effects boxes, etc.

905-301.....Stereo jack with SPST switch.....	.90
905-302.....Stereo jack with DPDT sw.....	1.00

**PGS ELECTRONICS**  
Route 25 - Box 304  
Terre Haute, IN 47802



# PROTEUS I <sup>T.M.</sup>

PROGRAMMABLE PRESET  
LEAD SYNTHESIZER

NOW AT A NEW  
LOW PRICE

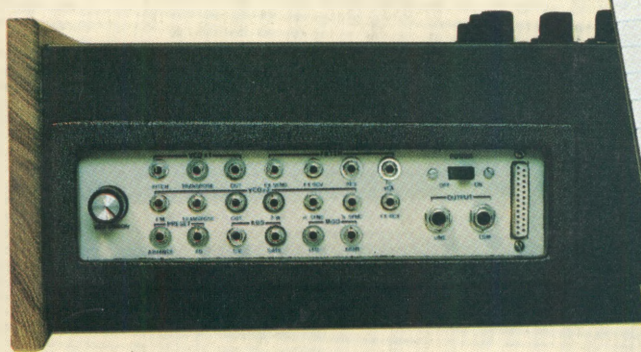

SAVE  
\$100

We had a lot of ambitious goals in mind when we began designing the Proteus I synthesizer.

We wanted, first of all, to provide a quality piece of equipment that would offer wide range precision and quiet, pure performance. So we designed Proteus around the world recognized Curtis Electromusic Chip Set to realize Oscillators and Filter with 12 octave range, transient generator segments out to 30 seconds long, exceptionally low noise and clean sound. Qualities you need for serious production work.

We wanted it to be easy to use on stage or in the studio. A keyboard that would let you get just the sound you wanted RIGHT NOW, without a lot of knob twiddling and switch throwing. So we gave Proteus 16 presets and simple controls that let you quickly and easily step from one preset to another or instantly switch between presets.

We knew you wouldn't want you to be locked into factory canned presets so we added an easy programming facility that let's you play with the sound and develop just the tone color, texture and feeling that you're after before saving the setting of every knob and switch with the push of a single button. And Proteus's internal memory keep-alive battery means that the preset will still be there even after months of power-down storage.

We knew that any normalization plan, no matter how clever and well planned, must in subtle ways define and restrict the kinds of sounds that a synthesizer can make. So after spending months developing and refining an exceptionally versatile normalization plan, we added the most liberal collection of patch over hardware points that you'll find on any synthesizer. The patch bay lets you integrate external processing elements into Proteus's signal path. Or interface to a wide variety of analog controllers like sequencers and function generators. Or

use optional footswitches to control preset functions. Or respond tomorrow to needs that you can't even imagine today.

We wanted Proteus to have a computer port that would set the standard for versatility and ease of use. While the interfacing provisions of some synthesizers are "tacked on", forcing you to choose between keyboard or computer control (but not both) and forget about front panel controls completely. The Proteus interface doesn't put the computer between you and your music. It puts the computer where it belongs, at your side to help when you want it to store or retrieve presets or keyboard sequences and completely out of the way when you don't want it. There aren't even any switches to throw, to use the computer, just plug it in.

We wanted to design a piece of equipment that despite its high-tech complexity would be easy to assemble and service, so we broke assembly down into small easily digested chunks with simple tests along the way that lets you monitor your progress and go from step to step with complete confidence.

To get the full details on the power and versatility of PROTEUS, send for your PROTEUS Using/Assembly Manual today and you'll also receive Craig Anderton's 20 minute demonstration cassette, [the cassette alone is worth the price] \$10 refundable on kit purchase.

ORDER TOLL FREE WITH VISA OR MASTERCARD

**1-800-654-8657**

1-8750 PROTEUS MANUAL ..... \$10 postpaid  
8750 PROTEUS I KIT was ~~\$499~~ now \$399 (26 lbs.)

Direct mail orders & inquiries to:

**RAI Electronics, Inc.**

1020 W. Wilshire, Oklahoma City, OK 73116 - (405)843-9626