

August 1983

# Polyphony™

ELECTRONICS-MUSIC-HOME RECORDING

\$2.50



**BUILD:**  
**A SIMPLE  
 DRUM  
 SYNTHESIZER**  
**THE ULTIMATE  
 COMPRESSOR**

**DONALD BUCHLA  
 INTERVIEW**

**DIGITAL DRUMS  
 AN OVERVIEW**





# T H E O B E R H E I M S Y S T E M

"Let me overturn a myth here—this is the greatest drum box for sound and programmability..."

Stewart Copeland  
(The Police)  
*Melody Maker*  
June 18, 1983

"The system inspires creativity and experimentation on every level."

David Sancious  
May 27, 1983

"In truth, these three little boxes (DMX, DSX & OB-8) will do far more than we yet know how to make use of musically."

Jim Aikin  
*Keyboard*/April 1983

"There's no other way to record a symphony by yourself..."

Sting (The Police)  
*Musician*/June 1983

"The interface with the DSX exponentially enlarges the possibilities of what I can do."

Jeff Lorber  
*Obernotes*/Fall 1982



**OBERHEIM  
ELECTRONICS, INC.**  
Some things are better than others.  
2250 So. Barrington Ave.  
Los Angeles, CA 90064

DX Digital  
Drum Machine  
\$1395.00  
Suggested retail

DMX Digital  
Drum Machine  
\$2895.00  
Suggested retail

DSX Digital  
Polyphonic  
Sequencer  
\$1995.00  
Suggested retail

OB-8 Polyphonic  
Programmable  
Synthesizer  
\$4395.00  
Suggested retail

700 Professional  
Stereo  
Power Amplifier  
\$895.00  
Suggested retail



# STAFF

PUBLISHER  
John S. Simonton, Jr.

EDITOR  
Craig Anderton

MANAGING EDITOR  
Linda Kay Brumfield

TECHNICAL ILLUSTRATOR  
Caroline Wood

CIRCULATION  
Ramona French  
Peggy Walker

BOOKEEPING  
Cathi Boggs

PRINT PRODUCTION  
Phuong Nguyen  
SEMCO Color Press

POLYPHONY (ISSN 0163-4534) is published bimonthly at 1020 W. Wilshire Blvd., Oklahoma City, OK 73116, by Polyphony Publishing Co. Entire contents copyright (c) 1982 by Polyphony Publishing Co. All rights reserved. No portion of this publication may be reproduced in any manner without written permission from the publisher. Second Class postage is paid at Oklahoma City, OK 73125.

ADVERTISING rate card and deadline schedule is available upon request. Contact Linda Brumfield at (405) 842-5480.

DEALERS & DISTRIBUTORS bulk prices are available upon request. Contact Linda Brumfield at (405) 842-5480.

SUBSCRIPTION rates:  
American 1 year \$12.00  
2 years \$22.00  
Foreign 1 year \$14.00  
2 years \$26.00

We now accept MasterCharge and Visa payment for subscriptions, back issues, and PolyMart items. Foreign payments must be by charge card, money order, or certified check in US funds drawn on a US bank.

BACK ISSUES are available at \$2.50 each ppd. Send SASE and request our 'Back Issue List' for a complete index of issues and their features, or see the back issue ad in this issue.

CHANGE OF ADDRESS notifications must include your former address and zip code, and any numbers from the mailing label, as well as your new address. When you move, be sure to notify your post office that you DO want second class and controlled circulation publications forwarded. This will save lost or returned issues. Polyphony is not responsible for replacement of lost or returned issues when we have not been supplied with change of address information.

TO POSTMASTER, send address changes to:

POLYPHONY  
PO Box 20305  
Oklahoma City, OK 73156  
Ph. (405) 842-5480

# CONTENTS

ISSN: 0163-4534

## Polyphony

Volume 8, Number 5

August, 1983

### FEATURES

- An Interview With Donald Buchla  
by: John K. Diliberto ..... 14
- Build a Simple Drum Synthesizer  
by: Doug Young ..... 36
- Digital Drums, An Overview  
by: Craig Anderton ..... 22
- Exploring Just Intonation  
by: David Doty ..... 38
- Fender's Triad Interface ..... 43
- Gate - Sample/Hold Circuit  
by: Michael Rogalski ..... 20
- The Penultimate Compressor  
By: Thomas Figueiredo ..... 10
- Viewpoint: Why Spring Reverb Will Never Die  
by: Craig O'Donnell ..... 18

### COLUMNS

- Book Review: Electronic Music: Systems, Techniques, and Controls  
by: David Doty ..... 9
- On Location: Concerts, US Festival, NAMM  
by: Craig Anderton ..... 5
- Practical Circuitry, Micro Drums Part I  
by Thomas Henry ..... 32
- Re-View  
by: Robert Carlberg ..... 4

### REGULARS

- Ad Index ..... 44
- Current Events ..... 27
- Equipment Exchange ..... 46

COVER PHOTOGRAPH by: Vesta Copestakes - CAVE GRAFIX

# re-view

Mnemonists **Biota** (Dys Records). All music is just noise, arranged in patterns we can recognize and identify with. The Mnemonists work with the raw materials of music, without the comforting reference points of tune or rhythm -- pure noise elevated to a nightmare soundtrack. The key to a good "noise portrait" is to keep you so busy trying to figure out how it was done that you never question why it was done. Mnemonists succeed.\*

Tomek Lamprecht **Tomek** (ATL 21057). Bass, guitar, and drums, aided by a Fairlight C.M.I., in funky tunes with occasional vocals, all by this one guy. It's pretty hot stuff.\*

Miles Davis **Star People** (CBS 38657). My biggest complaint with Miles is that he gets into patterns and can't break out -- I mean he must have remade **Jack Johnson** six times in the 70s. While this one and **We Want Miles** (see February '83) are definitely echoes of **Man with a Horn** (his big 1981 comeback album), at least it's a fertile field and he does add one interesting twist -- playing Oberheim as only a non-keyboardist could.

Marcus Miller **Suddenly** (Warner Bros. 23806-1). When **Man with a Horn** thrust this bass player into the "hot new talent" spotlight, a follow-up solo LP must have seemed inescapable. Unfortunately, he's a better bass player than songwriter/vocalist/synthesist, and the contrast is apparent.

Ricky Starbuster **Starburst** (cassette). The first release by one who intends to "make a career in this stuff or starve to death". He's got a better chance than most, with enjoyable pieces consisting of everything from introspective mood drones to punk rock (featuring the voice of his 6 year old niece). The majority have a quiet soloing over a repetitive background, not unlike Michael

Garrison, although Ricky's pieces are shorter and generally more daring. His equipment is top-notch: Prophet 5, Pro-1, and Roland drum unit (all self-programmed). A very full 90 minutes for \$8.50 postpaid from Starbuster Productions, PO Box 5582, Madison, WI 53705.

Various **Elektronische Musik** (Ornament CH7.921). Tape studio works in the old "cut-and-splice" style, including the usual oscillator sweeps, tape speed changes, odd taped tidbits, and text-poems (in a combination of German and English). Unlike some others, there's enough variety and subtle humor to keep it light and entertaining.\*

Gregory Taylor **Given Names** (cassette). A good collection of mesmerizing drones (mostly in the lower register) along with some uptempo numbers built on e-percussion and S & H triggers. Taylor's search for tonalities includes not only rich, vibrant synthesizer chords, but some unusual taped voice loops, soothing nature recordings, and guest spots by a guitarist, sax player, drummer, etc. \$6 plus postage from Taylor, 330 North Park Blvd., Glen Ellyn, IL 60137.

Moebius **Tonspuren** (Sky 083). It looks like the Teutonic explosion has about fizzled out. The "other half" of Cluster sets unfiltered, raspy synthesizer voices against each other in mechanical, predictable patterns. Even the cover tries to elevate ugliness -- a closeup photo of mindless graffiti over rusted metal. Nein danke.

Tyndall **Durch Die Zieten** (Sky 081). Sky is rapidly becoming the ECM of e.m., putting out joyless records with such endearing covers as a bare tree on a frozen plain. Jurgen Krehan and Rudolf Langer have programmed computers to repeat what sound like finger exercises ad infinitum over a rhythm box. Sound enticing?

von Deyen/Schuetz **Inventions** (Sky 082). Diester Schuetz is a guitarist, and Adelbert von Deyen a synthesist. I put this record on automatic repeat on my turntable, and after six or seven cycles it still hadn't made much of an impression. But I did get the Sunday paper read -- these short, pleasant, non-involving tunes are perfect for that.

Straight Shooter 5 (Sky 080). A cultural oddity -- heavy metal with synthesizers. Well, it's not really heavy metal, but it would like to be.

Culturcide **Year One** (L.P.). Culturcide has been described as modern day Faust, which tells only part of the story. As originators of much of the musical Dada movement of the 70s, Faust showed a lot of wit and verve. But their music was also uncommonly economical and unpretentious -- qualities singularly missing in Culturcide. Culturcide is more akin to Throbbing Gristle, based as it is on rhythm box, spoken lyrics, and distorted instruments. For pricing write Culturcide, 3305 Montrose #114, Houston TX 77006.

Peter Gabriel **Plays Live** (Geffen 4012). Live albums have always been kind of a contradiction: trying to capture the special excitement of a live concert with another recording, but without either duplicating the original recordings or changing them too much. Gabriel does a good job of proving that he can play his heavily-processed music live (see also February '83), but the rowdy audience, who whoop, holler, and yell requests (some even for Eno's music), prove more a distraction than an addition.

Nicola Frangione (ed.) **Mail Music Project** (LP 001). 47 artists from around the world were invited to send a free piece for this project, without any limits as to length or content. The results have been arranged chronologically according to date received, and released in a numbered edition of 1000. The artists range from obscure to unknown, and the pieces from very arty to extremely arty, but Frangione overlaps and edits them to keep things moving. \$15 postpaid from Frangione, Via Ortigara 17, 20052 Monza, Italy.

continued on page 9



# ON LOCATION:

# Concerts US Festival NAMM

**By: Craig Anderton**

Since a lot of you enjoyed reading about the activities that go along with being a Polyphony editor (February 1983 issue), here's the latest installment (subtitled "How I Spent My Summer In Search of Interesting Things to Write About").

One of my first priorities for the summer was seeing more live music, since (among other reasons) I feel it's my duty as editor to keep up with as much of the music scene as possible. I also wanted to find out how various groups solved certain staging problems inherent in the use of electronic instruments.

The first group I saw was Ultravox. The most striking aspect of their stage setup was that it was painted entirely in light gray -- amps, instruments, speaker cabinets, drum set, everything except the musicians. Dull, you say? Not when you carry good lighting equipment. Color changes were incredibly vivid when projected on an all-gray background, and in addition the lighting seemed to be computer-controlled and synchronized to the music on stage.

Their set was tight and included virtually all the post-John Foxx era "hits" -- "Sleepwalk", "New Europeans", "the Voice", "Reap the Wild Wind", and so on. Drummer Warren Cann alternated between standard drums and what sounded like a TR-808, often combining the two. Chris Cross played mostly synthesized bass (apparently synched to the drum unit), but when he switched over to electric bass, the visual jolt of movement (as opposed to standing behind a keyboard) helped keep the pacing moving right along. Billy Currie played keyboards and occasional violin (which the crowd loved), and Midge Ure added textures on guitar and keyboard, as well

as contributing one of the strongest and most expressive voices I've heard in a long time -- even late in the set on a vocally difficult song like "Vienna".

One of the highlights occurred when the stage lights dimmed, and four Simmons drum pads were lined up in a row. With Cann's drum machine purring away, all four musicians played in real-time on the Simmons pads. It was one amazing percussion break, and the audience reacted appropriately. Overall, Ultravox impressed me a lot. They have a power and professionalism on stage which is only hinted at on their records.

A few weeks later I saw Ronnie Montrose & Mitchell Froom at the Cotati Cabaret, one of my favorite venues in Northern California. (Montrose is well known for his guitar work with the groups Montrose and Gamma; what is not well known is that Montrose plays soldering iron too, and has built several custom devices as well as modified many commercial ones.) Anyway, Montrose and Froom have put together a synthesizer duo that uses programmed sequencers, drum machines, keyboards, and guitar to make a very full, electronically-assisted sound with only two people. The all-instrumental set touched a lot of bases -- improvisatory rock, electronic sounds, dance music, and even some touches of fusion-like jazz. But I was not only surprised by the richness of the sound; I was also amazed they could keep all this technology under control in a live performance contest. The technology is not really quite adequate yet to do what they're doing, but somehow Montrose and Froom pull it off (just wait until MIDI takes over...).

## ON LOCATION:

Highlights of the set included Montrose playing a custom-made percussion controller along with drum machine, and a powerful version of the theme from "the Good, the Bad, and the Ugly" that absolutely knocked me out. If you get the chance, catch Montrose and Froom's act -- they're musical and technological pros who wring some real music out of a bunch of silicon.

Next, I checked out the Us Festival with a couple of friends (audio/video technician David Karr, my collaborator on the PAIA "Vocal Zapper", and former DEVICE author Gary Kirkpatrick). For those who don't know what an Us Festival is, it's basically Steve Wozniak using the bucks he made from Apple Computer to stage his particular vision of Woodstock-for-the-80s. The 1982 version had mostly gotten pretty favorable reviews; it had been well-organized, but of particular interest to me was the technology fair section of the festival. This was billed as a high-technology exhibit that allowed hands-on meetings with computers, electronic instruments, etc.

The first good move we made was renting an R.V. and parking it close to the festival site, which was in Devore, California (near San Bernardino). Between the heat (often in the 100s) and the pollution (gasp, choke -- it was pretty bad), air conditioning never looked so good. Having a mobile kitchen also made us somewhat more independent of the synthefood being sold at the festival.

The event was spread over three days, with the first day being nominally "new wave" groups (INXS, Divynals, Wall of Voodoo, Oingo Boingo, English Beat, Flock of Seagulls, Stray Cats, and the Clash), the second day heavy metal (Judas Priest, Ozzy Osbourne, Scorpions, Van Halen, etc.), and the third day "top 40" (Berlin, Quarterflash, U2, Missing Persons, Pretenders, Joe Walsh, Stevie Nicks, and David Bowie).

As you might expect, the performers were ant-like dots on a distant stage; however, unlike many outdoor concerts, the sound was quite good. The total wattage was 400,000 Watts, but what really made the sound work was four speaker towers located halfway between the stage and the perimeter of the listening area. These were fed with time-delayed signals so that no matter where you sat, there was a minimum amount of echo. There were two large "Diamondvision" screens, bright enough so that you could even see them during daylight, which showed what was happening on stage. There were also two huge screens for nighttime viewing (each "day" typically ran from 10 AM to past midnight). While the technology was well-applied, I still feel there is no way that a loud sound system and video screens can substitute for seeing a hot group in a small club.

The first day had the most reserved, and smallest, audience ("only" about 150,000 people). My main conclusion at the end of the day was that most new wave music is simply not designed for stadiums and huge outdoor concerts; the audience seemed most responsive to the Stray Cats, anything but a new wave group. They seemed to love what they were doing, avoided the standard rock cliches ("hey-everybody-clap-your-hands-let's-party etc."), and perhaps most importantly, had simple instrumentation that carried well over the big space. Synthesizers definitely do not "carry" as well as guitar.

Heavy metal day was an experience -- 300,000 denim clad humans, mostly young men, attending a modern day ritual. It was something to walk into the festival area and see five times as many people sitting on a hillside as inhabit my entire county. Not being that big a heavy metal fan, I figured this would be a good day to check out the technology exhibits.

The premise of the Us Festival was that we should all work together, that technology is wonderful and can help us work together, and other vaguely-ESTish stuff. There was even a much-publicized and well-meaning (but probably ultimately irrelevant) live video hookup with the Soviet Union. Yet the technology exhibits themselves were very disappointing. What was there was fine (Danny Sofer showing off the Oberheim "System", for example), but there wasn't very much of it. I was told the technology exhibit was about half the size of the previous year.

Then there were the seminars...a chance to hear Emmett Chapman play and talk about the "Stick" (he sure can play that thing), and listen to Bob Moog, Robin Jigour (alphasyntauri), John Bowen (Sequential Circuits), and Chapman talk about instruments and subjects such as the MIDI interface. While I enjoyed running into all these people, and had a fine time chatting with Moog about computers and stuff (I think we both felt somewhat out of our element and were glad to see a kindred soul), the talks were poorly attended. Too bad -- the main reason I went to the Us Festival was because of the technological come-on, but in reality the whole thing was really not much more than a three day series of rock concerts.

The main attraction of the third day was David Bowie, who was exceptional. It was almost worth waiting what seemed like forever in the cold of the night, breathing air so foul you could develop film in it, to see his unusually crisp and professional show.

There was more, but you get the idea. There was good music, mediocre music; a couple of neat laser shows, whose effects were diluted by heavy-handed and naive propagandizing; crazy people, normal-looking people, but mostly, LOTS of people. Quite an experience.

Next on the agenda was the Chicago NAMM (National Association of Music Merchants) show, where all the manufacturers strut their new products. I'm sure every other music magazine will, by this time, have covered the event, so I'll keep it short. First, though, the disclaimers: I didn't see half of what I wanted to see, and I apologize in advance to those manufacturers who had neat products at the show which did not make it into this article.

Probably the most talked-about item among journalists at the show was the Kurzweil piano, shown in prototype form at a hotel suite. It was impressive. Basically, the Kurzweil is a sampling keyboard a la Emulator or Fairlight, but claims to use artificial intelligence to create a model of an instrument based on multiple samples of the instrument's sound. All I can say is regardless of whatever technology they use, the Kurzweil is amazing. The piano sound is uncannily like a piano -- dynamics, timbre changes, and all -- and the other sounds they demonstrated were equally strong. Kurzweil projects a price under \$10,000 and delivery in early 1984. We'll see...a lot of promising start-up companies



are never heard from again when faced with the realities of production and distribution, but I wish Kurzweil well and hope they succeed in what they're doing. Even as a prototype the piano seemed like a genuine breakthrough.

360 Systems introduced a relatively low-priced keyboard with digitally recorded sounds (strings, fuzz guitar, nylon string guitar, etc.). While not as sophisticated as the Kurzweil, the price/performance ratio showed that sampling instruments are no longer playthings for the elite.

The other big keyboard buzz was the long-awaited introduction of Yamaha's DX series of FM-based keyboards. The price is right (under \$2000 for their most costly model), and the sounds are different from standard analog synthesizers -- sort of bright, bell-like, and complex. There is also a breath controller available which helps create highly realistic brass articulations; however, I should emphasize that the DX keyboards are capable of far more than imitative synthesis. While I don't think that the DX series will displace standard analog synthesizers, if you're looking for an entirely new family of synthesized sound colors, Yamaha -- never a me-too company in the first place -- has come through.

In guitars, Fender probably got the most attention due to their re-designed line of amps (by technician and former DEVICE author Paul Rivera), and their revised guitars. The Steinberger guitar also generated a tremendous amount of excitement, and considering how great it sounds, that's not surprising.

I was disappointed once again to see that the infamous Roland GR-700 guitar synthesizer was nowhere to be found. Will it ever come out?

Drum machines were a big deal at the NAMM show. MXR introduced their Drum Computer, Linn was still showing the LinnDrum although rumors abounded that the next Linn product would be a combination drum machine and poly sequencer, Oberheim showed off the DX and DMX in conjunction with the Oberheim System, and E-mu continued to amaze and delight with the Drumulator (they also showed their pad programmer and IBM PC interface). All these companies seem to be selling drum machines as fast as they can make them, and I can see why...they're great fun (see the related article in this issue). Curiously, there was no Japanese entry in the digitally-recorded drums sweepstakes, although Yamaha showed some organs incorporating drum machines that used PCM digital recording.

Signal processing was dominated by digital delay lines, but Korg also showed a cute, inexpensive, good sounding effects system where individual effects boxes plugged into a compact pedalboard. This approach reduced the cost of the effects, so that you could buy four effects plus the pedalboard for the cost of four conventional effects. MXR showed their new "Precision" line and got good reactions, while DOD also showed their new line (the FX series).

In digital delays, Roland introduced a low-cost delay line that can sync to external events, as well as some other low cost delay devices. Ibanez has really cleaned up their act, producing delay lines with far better specs than last year's models while retaining competitive pricing.

# Not all Wireless Microphones are Created Equal



## This One Is A Telex

Recommendations by performers, as well as engineers, have made Telex the fastest growing wireless mic system in the industry.

Performers tell us they prefer Telex wireless mics because of the rich, full-bodied sound. And because the mics feel and look like conventional microphones.

To quote performers...the Telex wireless mic sounds superior to any I've used for vocals—wired or wireless...

...the freedom it gave our group sold me on the concept, and the sound sold me on Telex...

Audio and broadcast engineers stated that they prefer Telex because with just the addition of a second antenna, they have the most reliable diversity\* wireless mic receiver available, indoors or out. And because the compander circuitry provides dynamic range from a whisper to full fortissimo.

To quote engineers...the Telex wireless is the best we've tested, and we've checked them all...

...from a quarter mile, the signal was still crisp and clear...  
...for the money Telex outperformed all others we tried...

When you're ready for wireless mics, Telex offers you a choice of three VHF frequency groups, hand held or belt-pack transmitters, dynamic or electret microphones and a host of accessories. Compare our specs against any others, and by all means, compare the price. We're quite certain you'll also prefer Telex. Made in USA. Please write for full details.

\*US Patent No. 4293955. Other patents applied for

Quality Products for the Audio Professional



# TELEX®

TELEX COMMUNICATIONS, INC.

9600 Aldrich Ave. So., Minneapolis, MN 55420 U.S.A.  
Europe: Le Bonaparte—Office 711, Centre Affaires Paris-Nord, 93153 Le Blanc-Mesnil, France



## ON LOCATION:

Long delays (beyond 4 seconds or so) were also abundant. Electro-Harmonix (yes, they're back) showed off their new 64 second delay/recorder, which looked quite promising. DeltaLab showed the "Echo-tron", and used a demo tape I had recorded using the device as part of their show demonstration. This variation on the "Effectron" line delivers 4 seconds of delay for under \$700. DeltaLab also introduced a low-cost programmable delay line scheduled for introduction later this year. Audio/Digital showed a 6.5 second broadcast delay, and mentioned that soon their TC-2 digital delay would be expandable to 6.5 seconds (total cost of TC-2 plus expansion, about \$1400). Lexicon didn't have any new long delay products, but continued to spotlight the PCM-42 (one of the first long delays) and their other products. Incidentally, I've written an article about long delay techniques and manufacturers which will appear soon in Musician magazine.

What else was there? Well, the Fostex X-15 multitracker -- a portable 4 track recorder that lists for under \$500 -- caused a real stir; but a lot of the things I like best about a NAMM show happen after the show closes each day (and not all of it would be suitable for discussion in Polyphony!) Suffice it to say that I had a great time hanging out with fellow writers, editors, engineers, and musicians, eating everything from superb Italian food to sushi, and talking about anything that touched on electronics and/or music. NAMM shows are remarkable events but it's the people, as well as the products, that make the event remarkable.

After NAMM, I stopped over in Oklahoma to visit the folks at PAIA and of course, the Polyphony offices. There was a bunch of business that required tending to, but I also managed to spend some time hanging out with John Simonton at his local lake, swimming, coming up with new ideas for the magazine, and talking about his incredible VIC-20 based SMPTE program (which was in its final design stages). After all that time in Southern California and Chicago, it was a welcome change of pace to be somewhere with a more relaxed lifestyle.

After that, the summer started to wind down. I saw a Pat Metheny (jazz guitarist) concert in Berkeley, and it was very impressive. Pat Metheny has a truly engaging personality to go along with his superb musical sense, and unlike many flashy jazz musicians, played pretty egoless music. The band's new drummer (I didn't catch his name, but think it was Paul Wertico) was exceptionally solid and dynamic. The use of electronics was subtle yet pervasive, and despite being primarily a piano player, Lyle Mays showed a lot of sensitivity towards his synthesizers. Catching Metheny's band was a nice counterpoint to all the rock and techno-pop music I had seen. The electronics was just as important, but was far more delicately used and was, at all times, subservient to the players.

So that's how I spent my summer. I hope you enjoyed reading about it, and got some vicarious pleasure out of a little armchair travelling.

## Fast, Accurate, Transparent, Quiet . . . . Affordable



### QUALITY AUDIO KITS

## PHOENIX SYSTEMS

91 ELM STREET  
MANCHESTER CONNECTICUT 06040

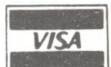

203-643-4484



# re-view

continued from page 4

**TRAX 0982 XTRA.** A compilation project of Piermario Ciani (also 1/47th of above), wherein 9 groups traded tapes back and forth until they seemed finished. Three of the 9 are made up of accomplished musicians playing normal instruments; the other six play "tape", "noises", and synthesizers. The final mix is an odd event, to say the least. \$5 plus post from Ciani, 33032 Bertiole, Udine, Italy.

**Michael Jackson Thriller** (Epic 38112). By now probably everyone has heard how hot this album is. Sure, a couple tracks with Paul McCartney and Vincent Price border on the ludicrous, but the rest is very surefooted. Listen in particular to the synthesizer work (from an even dozen studio synthesists) -- it doesn't dominate but it is very effective.

**The Creatures Feast** (Polydor SHELP-1). Songstress Siouxsie and her Banshee drummer Budgie with lots of studio reverb, tapes, and pseudo-Hawaiian posing. It's kind of cute.

**Bill Nelson Chimera** (Mercury B19). Similar in approach to Nelson's last release (see April '83), with the addition of some drumming by YMO's Yukihiro Takahashi. This is sort of a "home recording" -- Nelson plays nearly all the instruments (and there are a lot of them) and recorded the main tracks in his well-equipped home studio -- but the drum tracks were flown in from Japan. Ah, the marvels of multi-track.

**Talking Heads Speaking in Tongues** (Sire 23883-1). On one hand it's comforting to know that some things never change. After going off in their own individual directions (see Jan/Feb '82), the band can come together again and turn out an album nearly identical to the last one three years ago. On the other hand, where was this album two years ago when we needed it?

**Thomas Dolby The Golden Age of Wireless** (Capitol 12271). Dolby is similar to Peter Gabriel (see Feb '83) in that he fills out  
continued on page 35

# BOOK REVIEW

**Electronic Music: Systems, Techniques, and Controls** (second edition). By Allen Strange; published by William C. Brown Co., Dubuque, Iowa 1982.

**By: David Doty**

When the first edition of Allen Strange's Electronic Music appeared in 1972, it was a very nearly comprehensive guide to an emerging medium. In the decade following its initial publication, electronic music hardware and techniques have evolved rapidly, but until recently no similarly detailed book had emerged to chronicle the new developments. Now, this lack has been remedied by what is ostensibly a new edition of this same book. In fact, what we have here is an almost entirely new book, rather than a mere revision of the earlier work.

As stated in the preface, Strange, who is a faculty member at San Jose State University, intends his book as the text for a college course in electronic music. For this reason the synthesizer is portrayed as a modular monophonic instrument installed in an institutional studio. That most of the synthesizers in the world today are hard-wired and relatively portable is a fact that Mr. Strange has chosen to ignore. This fact need not trouble the potential reader too much, however, as the book explores the behavior of synthesizers primarily at the module and patch levels. While only the owners of large modular systems will be able to utilize all of the techniques in this compendious 272 page book, virtually any analog synthesizer on the market today can be understood in terms of the information presented here.

The organization of the book follows a fairly familiar plan, beginning with a brief chapter on the basic parameters of sound, followed by introductory accounts of the basic building blocks which make up all synthesizers. Successive chapters introduce the concept of voltage control and the various types of sub-audio and audio-rate modulation. Each technique presented is illustrated by one or more patches, in a version of the standard patch chart familiar to regular Polyphony readers. Often, several alternative patches are presented, to illustrate that different methods can be used to obtain similar results from different systems. The selection of techniques and devices enumerated is exhaustive, including such relatively recent developments as linear F.M. and hard and soft sync, and exotic devices such as frequency shifters and vocoders.

Having thoroughly examined all of the components of the typical modular synthesizer, Strange goes on to offer chapters on the various other devices commonly found in an electronic music studio, including tape decks, mixers, and reverb units. While these chapters are not always as detailed or as up-to-date as those concerned with synthesizer modules, they still constitute a valuable resource for anyone wishing to become familiar with the operation of an electronic music studio. The book concludes with a chapter on performance electronics and a collection of scores for performance. This

continued on page 12

# The Penultimate Compressor

By: Thomas Figueiredo

I became interested in the NE572 high performance compander IC because I've always had an obsession to find the best sounding compressor. This circuit comes close to the realization of a perfect compressor. The NE572, like the NE570, has two separate channels or gain blocks to work with. In this circuit we use both halves of the IC.

Some problems that plague all single channel compressors are third harmonic distortion and low frequency distortion (due to control signal ripple), along with high frequency channel overload and noise modulation (i.e. "breathing"). The first two prob-

lems are solved by compressing the high and low frequencies separately.

A1, A2, A3 and their associated components in figure 1 form an active electronic crossover with a 1 kHz crossover point. These are 3rd order Butterworth filters which exhibit -18 dB per octave cutoff and flat magnitude response. LF356s are chosen as the active devices for their very high input impedance, fast slew rate, and extremely stable operation into capacitive loads (see National Semiconductor "Audio Handbook", 1980 edition). They are also very quiet, and in my opinion bi-fets are the best

choice for a high impedance input stage. Since input buffer A1 and the active filters it drives (A2 and A3) are both inverting, the crossover output is non-inverting with respect to the input.

The next stage (see figure 2) consists of two parallel compressors built around the NE572, and includes A4, A5, and A7 through A14. The circuit is only drawn once for the sake of brevity, however it must be repeated twice using each half of the NE572.

A4 and A5 are external op amps in the feedback loop of the compressor. I chose the NE5534N, however a dual type such as the NE5532 could be used for A4 and

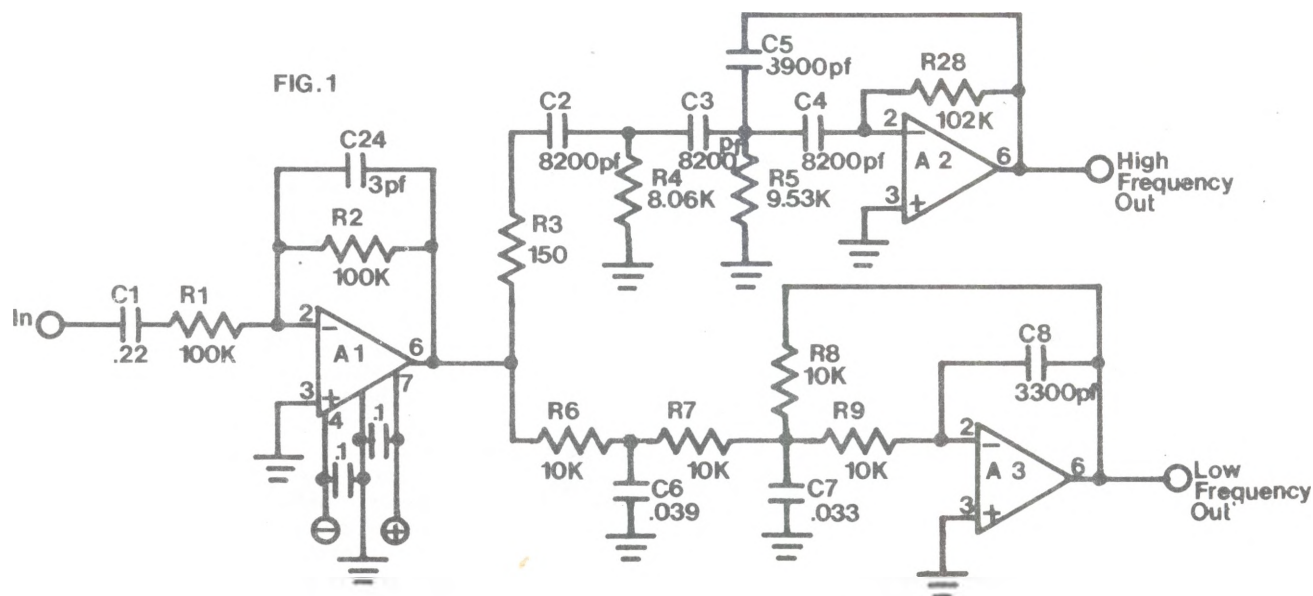



A5. D1, D2 and D11, D12 limit the output to approximately 7 Volts peak-to-peak, which protects the equipment following the compressor. C19 and C24 assure that the diode capacitance doesn't interfere with full audio bandwidth operation.

C22 and C23 are the attack capacitors. They determine the attack time of the compressor, in other words, the amount of time it takes the compressor to react to an incoming signal. With a 0.1  $\mu$ F cap giving an attack time of 4 ms at high frequencies, and a 1  $\mu$ F cap giving an attack time of 40 ms at low frequencies, the result is very low distortion.

C20 and C21 are the recovery capacitors; they determine the amount of time it takes the compressor to release. They can also be thought of as controlling the amount of sustain. A recovery cap

of 4.7  $\mu$ F yields a 200 ms recovery time, as recommended by the May 1981 Signetics "Companer Product Guide" for high end audio processing. I chose 10  $\mu$ F capacitors, resulting in a 400 ms recovery time which gives more sustain with guitar.

Simple companer systems are subject to a problem called breathing. As the system changes gain, the change in the background noise level can sometimes be audible. In our design the circuits built around C20, C21 and C22, C23, along with op amps A7 through A14, buffer the timing capacitors and allow improved accuracy of the compressor with low level signals. Combining this technique with band-splitting virtually eliminates any breathing problems.

A7 through A14 could be 1/4 of an LM324. I chose TL084s however, because bi-fets cause less

loading due to their high input impedance.

Op amps A4 and A5 are configured in the inverting mode. We need another inversion, which is accomplished in the next stage.

Op amp A6 is our output mixer. I chose an NE5534A for this stage (see figure 3). R32 and R33 limit the current consumption to approximately  $\pm 10$  mA (these resistors are necessary on any NE5534 in the circuit; see the May 1981 Signetics application note, "Single and Dual Low Noise Operational Amplifier"). A4 and A5 require the same treatment to prevent large quiescent currents from flowing due to the 2 to 3 Volt DC offset at pin 6 of A4 and A5. This bias is induced at pin 3; it may be trimmed out by adding 82k to 100k resistors from the +15V supply to pin 2 of A4 and A5. However, this introduces extra hiss, so I recommend not worrying about the offset since it does not affect the audio performance of the op amps.

Bypass capacitors C28 through C31 are necessary with the NE5534 to isolate the op amp from any spurious noise riding along on the power supply lines. It's also good practice to add bypass caps to A1 through A3 as well; in fact, this is recommended for bi-fet op amp applications in general.

**Finding parts, and other tips.** This circuit is relatively complex and many of the parts are hard to locate. The resistors and most of the capacitors are available from Mouser Electronics (11511 Woodside Avenue, Lakeside, CA 92040). The NE572, NE5532, and NE5534 are available from PGS Electronics (Route 25/Box 304, Terre Haute, In 47802). The NE572 and TL084 are available from Radio Shack. Also note that power supply connections and pinouts for A7 through A14 are not shown since a number of different op amps will

FIG. 2

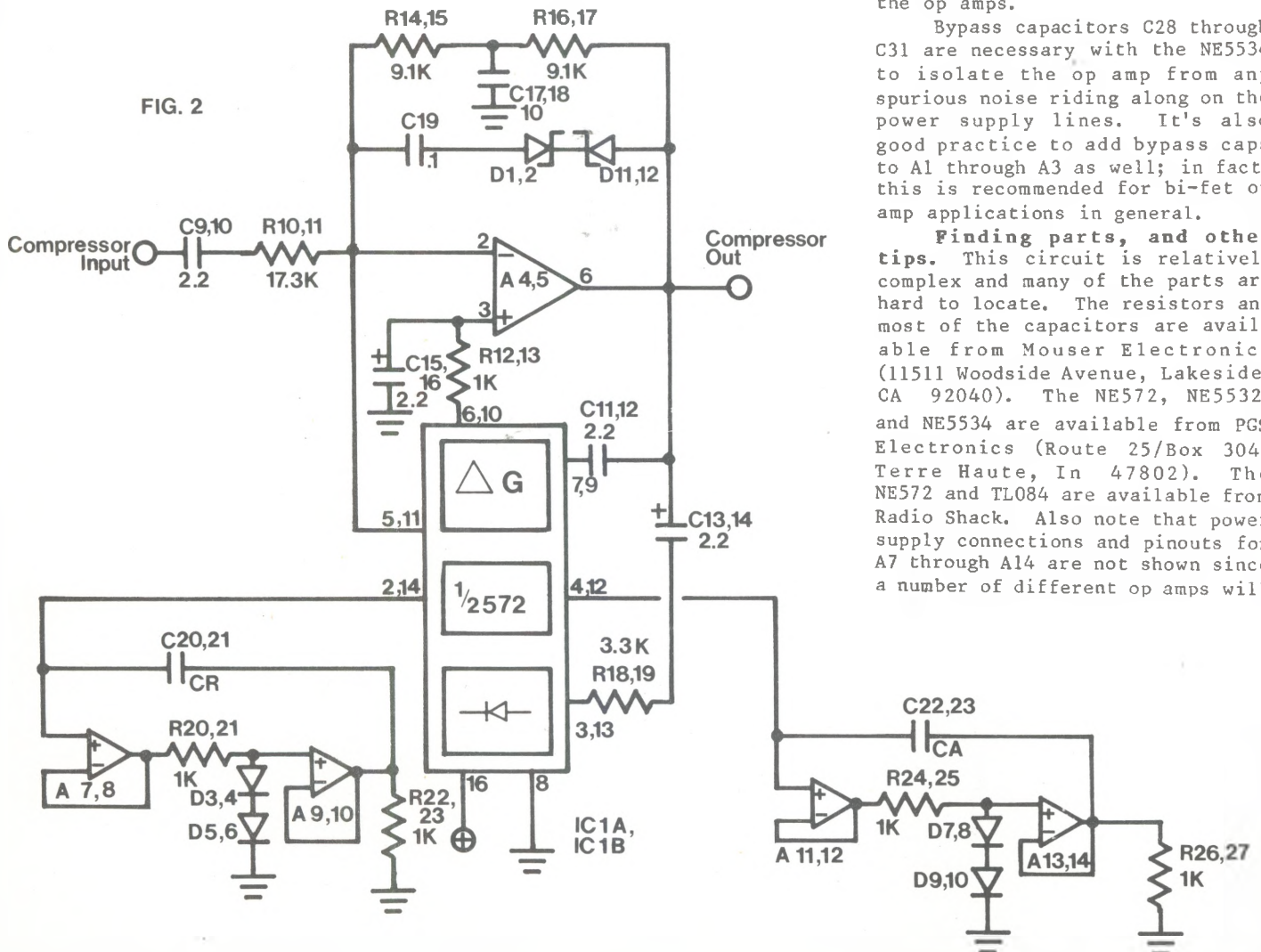

work. Pinouts can be found on the IC spec sheet or package (i.e., Radio Shack parts package).

For best stability, all filter caps should be polystyrene or mylar, and all timing caps (for attack time, release time, etc.) should be tantalum or mylar. All resistors in the inputs and feedback loops of the audio amps should be metal film, 1% types (although you can use a DVM to match 5% tolerance types if you have a bunch to choose from Ed.). Finally, it's necessary to use a well-regulated and filtered +15 Volt power supply.

#### PARTS LIST

Resistors (see text)

R1, R2, R34	100k
R3	150 Ohms
R4	8.06k
R5	9.53k
R6-R9, R29-R31	10k
R10, R11	17.3k
R12, R13, R20-R27	1k
R14-R17	9.1k
R18, R19	3.3k
R28	102k
R32, R33	100 Ohms

Capacitors (see text)

C1	0.22 uF
C2-C4	8200 pF
C5	3900 pF
C6	0.039 uF
C7	0.033 uF
C8	3300 pF
C9-C16, C25-C26	2.2 uF
C17, C18, C28, C31	10 uF
C19, C24, C29, C30	0.1 uF
C20, C21	see text
C22, C23	see text
C27	5 pF
C32	22 pF

Semiconductors

D1, D2, D11, D12	3.6V Zener diode
D3-D10	1N914 or equivalent
A1-A3	LF356 bi-fet op amp
A4, A5, A6	NE5534A op amp
A7-A14	LM324 or TL084 (see text)
IC1	NE572 compander

Misc.                      Sockets, jacks, box, etc.

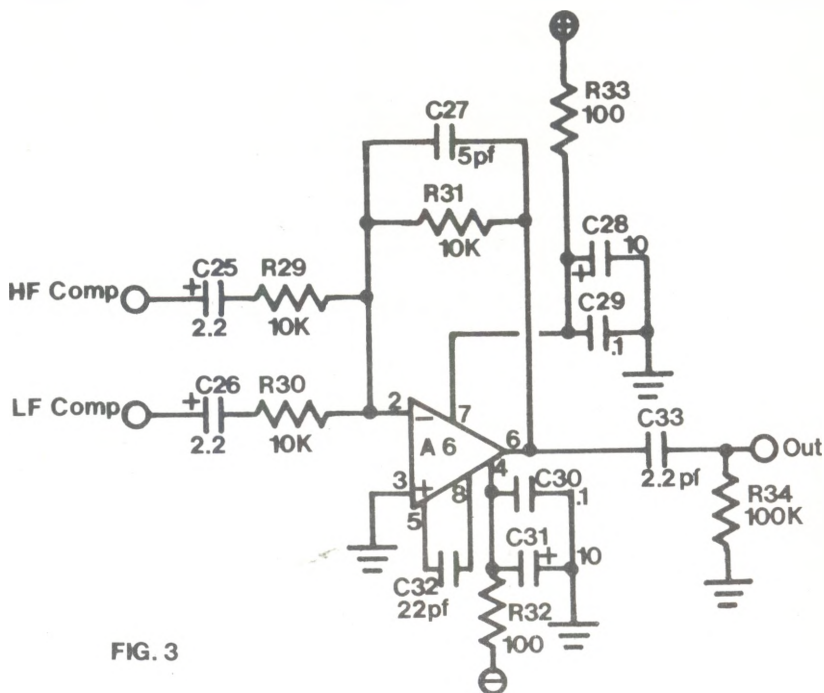

FIG. 3

## → BOOK REVIEW

continued from page 9

section of the book will likely prove the least useful for most readers, as the circumstances described clearly belong to the academic avant-garde of the 60s and early 70s. It is doubtful that many non-academic readers will have either the equipment or the inclination to perform Strange's Vanity Faire or Douglas Leedy's Entropical Paradise (with Birdcall). There are, however, some useful tips on organizing and troubleshooting a performance setup.

Taken as a whole, Electronic Music: Systems, Techniques, and Controls should prove a valuable resource for any student of synthesis. More experienced players may find that its encyclopedic collection of patches alone justifies the \$11.75 price. My only real complaint about this book, and it is a relatively minor one, concerns its style. Because of its academic orientation, the language used is sometimes more pedantic than the content seems to require. I hope that this fact does not discourage any would-be readers from utilizing what is clearly the most comprehensive electronic music book on the market today.



# PLAY DRUMS AND GUITAR-AT THE SAME TIME?

**Yes!! with Electro-Harmonix' new INSTANT REPLAY you can accent your playing with any sound under the sun.**

Glass breaking, a chord or lick from a guitar or synth, *real* handclaps, vocal sounds like burps, yells or singing – ANY sound that can be picked up by a microphone, produced by a guitar or other electronic instrument or transferred from tape!!

Push a button on the **INSTANT REPLAY**, a red LED comes on and you're ready to record. You can now input up to 2 seconds

of any sound you want into the unit's digital memory. That same sound can then be *instantly* replayed by hitting the external drum pad that comes with the **INSTANT REPLAY**. The pad is touch-sensitive, so a harder beat produces a louder sound, and the *pitch* of the sound can be transposed if you like – make your voice sound like Darth Vader or The Chipmunks! A continuously looping replay of the sound is also possible, providing an opportunity for sequenced or metronomic effects.

The **INSTANT REPLAY** isn't limited just to drummers. Guitarists and keyboard players can trigger the replay with a tap of the hand or foot, INSTANTLY generating the creative, unique sounds that have been stored in the unit.

The **INSTANT REPLAY**, available at leading music stores throughout the world, gives you access to sounds and effects previously obtainable only on the Fairlight or Emulator, but at a small fraction of their cost. It comes with all necessary hardware to mount on Roto-Tom and most brands of cymbal stands.

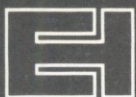

ELECTRO HARMONIX

The Best Sounding Effects In The World!!

27 West 23rd St. • NYC, NY 10010 • (212) 741-1770



# An Interview With Donald Buchla

By: John K.  
Diliberto

*"I think that electronic technology offers us the possibility of divorcing ourselves from the necessity of virtuosity, without divorcing ourselves from the possibility of intense and meaningful interaction with our instruments."*

Donald Buchla is a classic American loner -- a living realization of the all-too-mythical individualist who follows his particular vision despite all the obstacles, hardships, derision, and easy exits that are available to him. Like Lewis and Clark, Buckminster Fuller, and Harry Partch he flies against the winds of convention and sometimes, by his very effort, changes those conventions.

Donald Buchla makes electronic music instruments. And though those instruments resemble what we know as synthesizers, and work in much the same way, Buchla insists that they are not synthesizers. He sees each of his devices as part of the larger electronic music instrument family. "Electronic instruments are a family of instruments", he claims, "just like the wind family, the brass family, or members of the string family."

Buchla began designing instruments for the electronic family when he was at the San Francisco Tape Music Center in 1962. His name and instruments are not as widely known as those of Moog, Arp, or Prophet, but among those who know electronic instruments, the name Buchla is one to reckon with. He's generally credited with arriving at the voltage control modular synthesizer at the same time as Robert Moog. But from that point on their parallel paths diverge. Moog geared his instruments towards a burgeoning popular market that he in fact had created. His instruments were tailored to the expressed needs of

musicians like Wendy Carlos, Keith Emerson, Tomita, and Jan Hammer. Buchla, on the other hand, was himself a practicing musician and composer. He's a self-proclaimed avant-gardist and experimentalist, and his instruments reflect those concerns. He is opposed to the concept of imitative synthesis to the point that he doesn't even like having keyboards on his instruments: his concession is a metal touch-plate system. So, it's not surprising to him or anyone else that his instruments have been embraced by artists on the sonic frontiers, such as Morton Subotnick, rather than the popular mainstream.

Determined individualism can become self-righteous smugness with some artists, and Buchla has been almost willfully obscure in pursuit of his musical purity. More than one musician has told me stories about trying to buy a Buchla instrument and actually being turned down because Buchla didn't think their music was serious enough.

Despite being an innovator of electronic music design, Buchla claims to know little about the actual technology in his creations. "I don't care about circuitry", he asserts. "I design my instruments from the outside in". He speaks of music in terms of language, gesture orientation, and interactiveness. He doesn't seek the touch-sensitivity of so many keyboard synthesizers, but rather an almost cybernetic interface between the body, mind, and instrument. His own concert performances entail audience interaction with his computers. He relates how at one concert he gave flashlights to audience members, who then aimed them at a screen which triggered the instruments. With Buchla conducting and playing his instrument, it created a true feedback loop between artist and audience.

Buchla is now involved with digital technology. His newest instruments, the 400 Series, de-



part from his modular designs and contain everything, including a touch-plate keyboard and real-time score editor, in a unit the size of a medium suitcase. (The 406 Model has a more traditional weighted claviers keyboard.) You can create any waveshape imaginable with this instrument. During a demonstration he gave me, one waveshape looked like a coastal map of Norway and sounded equally jagged and complex.

After more than 20 years in the vanguard, Buchla has evolved an enigmatic personality that tends to undercut his obvious enthusiasm for his music and instruments. His Sahara-dry humor cuts through many of his often cryptic answers, at once daring and provoking further inquiries. But he was also happy to talk about his creations and verbalize the concepts that are embodied in a Buchla electronic instrument. As he said, "I'm used to sitting in my ivory tower and passing schematics out under the door. I don't get to talk about them that much". Here, Donald Buchla talks.

**John Diliberto:** When did you start putting together electronic components and synthesizers?

**Donald Buchla:** Electronic musical instruments in about 1961-62.

**JD:** What were you working with then?

**DB:** Instruments of my own invention. They were an outgrowth of my own personal need and acoustic instruments.

**JD:** So you came to it as a musician.

**DB:** Yes, as opposed to a technician.

**JD:** What were the instruments that you were working with at the time?

**DB:** Well, the studio of the early 60s, the traditional studio, was equipped with an array of electronic instruments, none of which were designed to make music. The concept of designing electronic instruments was new at the time. My first instrument was a device that read the shape of the hand and interpreted it as a waveshape. It embodied the philosophy that the instrument had to be highly interactive with the human being who was playing it. It was a way of transcending the limitations of the instruments that I was acquainted with, which tended to be Hewlett-Packard oscillators, Ampex test equipment, borrowed World War II gunsights and such

---

***"I'm concerned with language and input structure every bit as much as I'm concerned with generative structure."***

---

**JD:** A lot of people feel that the recent generation of synthesizers is still very non-interactive.

**DB:** I'd say that's generally true.

**JD:** What then makes yours interactive?

**DB:** I'm concerned with language and input structure every bit as much as I'm concerned with generative structure.

**JD:** How does that translate into your electronic designs?

**DB:** It influences the man-machine interface, the way one communicates with the instrument. It takes place at the tactile level and the language level.

**JD:** It seems that one of the benefits of synthesizers is that they have made music more a function of the mind and less a function of tactile dexterity, something that has been the tradition of music for hundreds of years.

**DB:** Well you chose the word dexterity, I didn't. I think that electronic technology offers us the possibility of divorcing ourselves from the necessity of virtuosity, without divorcing ourselves from the possibility of intense and meaningful interaction with our instruments.

---

***"I wouldn't call anything that I've built a synthesizer."***

---

**JD:** When did you first start designing what you might call a synthesizer?

**DB:** I wouldn't call anything that I've built a synthesizer. I first started designing members of the electronic family of instruments in 1962.

**JD:** What differentiates what you design from a synthesizer?

**DB:** A synthesizer, according to popular usage, is a keyboard instrument with the expectation that when you strike a particular key that you will get a particular pitch. I would even extend the expectation to having a certain type of oscillator followed by a filter and a gate, keyed by an envelope with an expected rise time, fall time, sustain, and so on. I would expect a certain

imitative aspect to a synthesizer -- imitative to the extent of copying what we expect from percussive sounds of the world to which we are accustomed.

---

***"I have always been outside and I've chosen to remain there. I've been an experimentalist since my early childhood."***

---

**JD:** Why did you feel a need to go outside these expectations?

**DB:** Because I didn't feel a need to go inside them. I have always been outside and I've chosen to remain there. I've been an experimentalist since my early childhood. I've been interested in avant-garde and experimental music far more than I've been interested in, as a composer, more traditional form and structure. My instruments have reflected that need.

---

***"I grew up surprisingly ignorant of what was going on in other people's music."***

---

***"...there are hundreds of thousands of people interested in alternative modes of expression."***

---

**JD:** Who were some of the people that you were listening to in your early days?

**DB:** I grew up surprisingly ignorant of what was going on in other people's music. I was amazed to find, in the early sixties, people in San Francisco that were composing and experimenting along lines that did not adhere to the status quo. Since then I've learned that there are hundreds of thousands of people interested in alternative modes of expression.

**JD:** Outside technology is still having an effect on electronic instrument design.

---

***"The advent of the microcomputer has really made it possible to make the electronic medium a very viable performance medium."***

---

***"Before the microcomputer, we were very limited as performers."***

---

**DB:** The advent of the microcomputer has really made it possible to make the electronic medium a very viable performance medium. Before the microcomputer, we were very limited as performers. But now we have a flexibility that should be admired by a player of an instrument.

**JD:** The touch-plates are something that is very much associated with your instruments. Why did you go to them instead of some other triggering device?

**DB:** Well, it's a cop-out, a compromise between the expectations and demands -- the psychological demands, at least -- of the black and white keyboard versus the generality of the sky-blue input structure. It's easy to adapt to the expectations that many of us have, and easy to transcend those same expectations with a keyboard oriented in slightly known traditional ways.

---

***"...music as we know it is rooted in a great deal of tradition, and is resistant to change on many levels..."***

---

**JD:** Your basic philosophy seems to be derived from a concept of breaking away from any traditions that preceeded you.

**DB:** I would guess so, yeah. My own interests are in that direction. We're tradition bound. We have concepts of what music is, and what is and what is not music. We have virtuosity, that is performance technique, developed after years of study and centuries of tradition. We have instruments that have been refined and refined, generation after generation. So music as we know it is rooted in a great deal of tradition, and is resistant to change on many levels: the instrumental, the performance, and the listening levels. I'm not well-rooted in any of the traditions and I'd like to investigate the sonic experience in a very general way.

**JD:** Do you think that electronics are a better way of delving into sound?

**DB:** I'm not that involved with the intricacies of sound as some. I pursue the investigations of timbre, but I'm more concerned with the investigation of musical structure. I think that's where more music lies, than with what we might call the static timbres.

**JD:** You and Robert Moog began

developing electronic instruments at about the same time.

**DB:** Yes, we both had our starts about the same time. We both used modular designs also. The idea of voltage control was significant in that it allowed us the possibility of discreetness in realms that were otherwise limited to continuums. Everybody's favorite oscillator in 1961 was the Hewlett-Packard because it was very stable and predictable, and very well calibrated. The big limitation was accepted as something that could never be transcended, namely it had a knob on it so that if you wanted to go from 440 Hz to 770 Hz you had to go through every frequency inbetween. Consequently, to make a jump in frequency you had to splice a tape and put the pieces together. As simple as that may seem, it was a very fundamental limitation of the classical studio. Voltage control allowed us to generate and conceive discreet changes in pitch, as opposed to continuous changes. We can then extend that the voltage control of other parameters.

The concept of the modular design was the original concept of the synthesizer, that is to synthesize the whole out of the sum of the parts. And the modules were the parts. If we needed a lot of generators we would obtain a lot of modules that had generative functions. If we wanted to do a lot of analysis, we would obtain modules that did envelope detection and perhaps filtering. If we wanted rhythmic elements, we would string together a lot of sequencers. So the modules allowed us to engress ourselves in different kinds of biases, depending on what we were interested in. If we wanted we could emphasize the structure, or the density or processing capabilities versus the generative capabilities. It allowed us interconnection at a very important level, that is the structural level as opposed to systems that came along shortly thereafter that made all kinds of assumptions like the sawtooth should precede the filter, should precede the envelope generator or whatever. I don't even know how the typical synthesizer has come together.

**JD:** How would you compare your work to Moog's?

**DB:** It's like comparing apples to oranges. Both of us are making viable additions to the musical instrument family. I suppose his

instruments have been more oriented to traditional concepts of musical structure and mine towards non-traditional concepts. At one time we were considered to be West coast versus East coast and in some sense there is truth to that concept. Certainly ten or twenty years ago more experimentation took place on the West coast than the East coast.

**JD:** Electronic instruments have changed since the first Moog and Buchlas with their big patchboards attached to a keyboard. What ideas have gone into those changes?

**DB:** A lot of learning has gone down in twenty years. We've found that certain kinds of structural interactions can be assumed. Certain others can be taken over by the computer that controls the innards of our instruments, and can be specified in a way that can make changes in patches instantaneous instead of tedious. The computer has made a lot of changes but it's only a small part of it. The language is the major part of it. The operative language behind our instrument has taken over a lot of the role of establishing

---

***"Therein lies the exciting possibilities of electronic instruments: the instantaneous re-mapping of the relationship between input gesture and output response."***

---

the relationship between input gesture and instrumental responses.

**JD:** What do you mean when you speak of language?

**DB:** I like to regard an instrument as consisting of three major parts: an input structure that we contact physically, an output structure that generates the sound, and a connection between the two. The electronic family of instruments offers us the limitation, if we approach it traditionally, and the freedom if we approach it in a new way, of total independence between input and output. And in fact the necessity of some way of generating a connection between the two. Language becomes an important aspect in the electronic family of instruments, where it had played no part with all traditional acoustic instruments. The relationship between input and output is fixed with traditional instruments; it's to-



tally flexible with electronic instruments. It was established by the setting of knobs and routing of the patch cords in the electronic instrument of the 60s. But in the electronic instruments of the 80s it is established by human intelligence working through sophisticated electronics. Therein lies the exciting possibilities of electronic instruments: the instantaneous remapping of the relationship between input gesture and output response. We've only begun to investigate this because of our own ignorance and our dedication to tradition, in that we continue to build electronic instruments with linear additive input structures, assumptive connective structures and imitative output structures.

**JD:** You talk about gesture orientation and interaction with the instrument, yet touch-plates hardly seem to give musicians the touch-sensitivity that a lot of them want.

**DB:** Those same musicians are the ones who go into the stores and say "I'm the keyboard player from such and such group and I'd like to see what you have in the way of 'synthesizers'." And the rock and roll synthesizer expert shows all the black and white keyboards and sure enough, they're all spring-loaded keyboards with switches on the other end. They're all organ keyboards and they're all adaptations of something that was developed to throw hammers at strings. It's a really crude problem and not too graceful an answer. That's what these guys have demanded, that's what the marketers have picked up on, and that's all we've got down there in synthesizer-land. These same guys that are complaining that their \$6,000 instrument doesn't make every sound that they want, that it won't imitate anything, finally start to realize that it really will make any sound. But it won't imitate the musical structure of the thing that they had in their minds that it would do. The reason that it won't do that is that it only has a finite number of pitches and they're all designated as pitches. There's no interaction between them. It's all a very simple linear-additive system

**"I didn't claim to solve the problem. I'm just here to elucidate it."**

that doesn't lend itself to alternative musical structures. Did I evade your question?

**JD:** Yes you did.

**DB:** I didn't claim to solve the problem. I'm just here to elucidate it.

**JD:** Is it a problem that you want to solve?

**DB:** No. What I try to do is persuade as many people as possible that are in a position of influencing our musical heritage and instrument design, to look on the possibilities of the electronic family as a legitimate family of musical instruments and not as an imitation or a bastard or a space wars. We should have the

***"What I try to do is persuade as many people as possible that are in a position of influencing our musical heritage and instrument design, to look on the possibilities of the electronic family as a legitimate family of musical instruments..."***

same variety of approaches in the electronic family as any other family. We should stop competing with each other and saying that, say, the Prophet is better than the Oberheim. That's a bunch of crap. Let's stop aiming towards the same pie-in-the-sky, and start developing a variety of instrumental approaches and musical techniques and performances. Let's get something that reflects the true possibilities of the technology at hand, as well as the music and creativity behind them.

***"We should have the same variety of approaches in the electronic family as any other family."***

**NEXT ISSUE:**

**BUILD AN  
ELECTRONIC  
BASS DRUM!**

## ELECTRONIC PROJECTS FOR MUSICIANS

Project kits now available  
exclusively from PAIA and  
for a limited time at a special  
"10% off" sale price

Proj. #	Title	Regular Price	Sale Price
1	Preamp (less XLR and VU)	\$22.95	\$20.65
2	Metronome	\$19.95	\$17.94
3	Passive Tone Control	\$16.95	\$15.25
4	Headphone Amp.	\$19.95	\$17.95
5	Mini-Amp	\$29.95	\$26.95
6	Ultra-Fuzz	\$19.95	\$17.95
7	Bass-Fuzz	\$21.95	\$19.65
8	Compressor/Limiter	\$27.95	\$25.25
9	Ring Modulator	\$29.45	\$26.95
10	Dual Filter Voicing Unit	\$29.95	\$26.95
13	Bipolar AC Adapter	\$34.95	\$31.45
14	Treble Booster	\$12.99	\$11.65
15	Electronic Footswitch	\$19.95	\$17.95
16	Tuning Standard	\$39.95	\$35.95
17	Super Tone Control	\$29.95	\$26.95
18	8 in., 1 out Mixer (less XLR)	\$18.98	\$26.06
20	Practice Play Along	\$27.95	\$22.45
21	Phase Shifter	\$41.95	\$49.45
24	Tube Sound Fuzz	\$22.95	\$20.65
25	Envelope Follower	\$26.95	\$24.25
26	Spuller (less optional parts)	\$14.95	\$13.45
27	Noise Gate	\$32.95	\$29.65

ADD \$3.00 POSTAGE AND HANDLING WITH YOUR ORDER.

These are kits of parts and circuit board only, to allow maximum flexibility in their application no cases or enclosure are included. Instructions for the assembly of each item are part of the book *Electronics Projects For Musicians* (\$14.95 plus \$1.00 postage) and are not duplicated with the kit.

CHARGE TO VISA OR MC TOLL-FREE  
1-800-654-8657 9AM to 5PM CST MON-FRI

DIRECT INQUIRIES TO

**PAIA Electronics, Inc.**

1020 W. Wilshire, Oklahoma City, OK 73116 • (405)843-9626



It's ironic that while the electronics of your synthesizer is capable of subtlety of tone and color that are unprecedented in the history of music, you would be better off playing a typewriter for all the control of dynamics and expression you have from the keyboard. Now you can change that with PAIA's new Veloci-Touch Controller. This simple to build and install retro-fit for most electronic keyboards adds three important control parameters:

- **Second Touch Pressure** — pitch bends and vibrato the natural way.
- **Velocity** — as you play harder, output signal level increases.
- **Velocity Transient** — apply to filter or voltage controlled distortion device for dynamic timbral changes.

And best of all is the incredibly low cost. Retro-fit versions are available from less than \$45.00. Stand-alone package with case and power supply (shown in the photo) less than \$70.00.

Get the full details from our latest catalog of electronic kits for stage and studio. It's yours FREE by calling:

1-800-654-8657

**PAIA Electronics, Inc.**

1020 W. Wilshire, Oklahoma City, OK 73116 • (405)843-9626

August 1983

17

# Viewpoint:

## Why Spring Reverb Will Never Die

By: Craig O'Donnell

(Craig O'Donnell is a member of the Scientific Americans, and has some unique ideas about the role of technology.)

"I don't care what people say, rock & roll is here to stay" -- Danny and the Juniors

Danny seems to be right, and I contend that as long as there's music being recorded there will be spring reverbs. Why? How about cost, sturdiness, technological advances, size, and new applications? These have all combined to bring the spring back, especially in small studios.

What is a spring reverb? It's simply a preamp stage (sometimes with EQ), a driver similar in principle to a speaker, some springs which delay the electrical signal, a pickup similar in principle to a microphone, a pickup amplifier, and an output buffer. Other bells and whistles are added at the whim of each designer. The principle is EXACTLY that used in an acoustic reverb chamber: "dry sound" travels to an electromagnetic transducer (speaker) and when the sound's electronic waveshape propagates through the air, a time delay results. Luckily, the speed of light and the speed of sound are wildly different in magnitude. A transducer (microphone) picks up the sound bouncing around the reverb chamber and takes what it "hears" back to the mixing console. Springs have internal reflections and reinforcement/cancellation patterns just like a "live" room. Pretty elegant, no?

The spring reverb is so handy and so omnipresent that we should appreciate its good points. Spring reverb technology was pretty much stalled until a few years ago: the Hammond-type reverb like those in a Fender Twin Reverb amp was what you got. As the 70s progressed we saw improvements; Orban and others came out with reverbs with an input limiter (less spring) and equalization controls to doctor

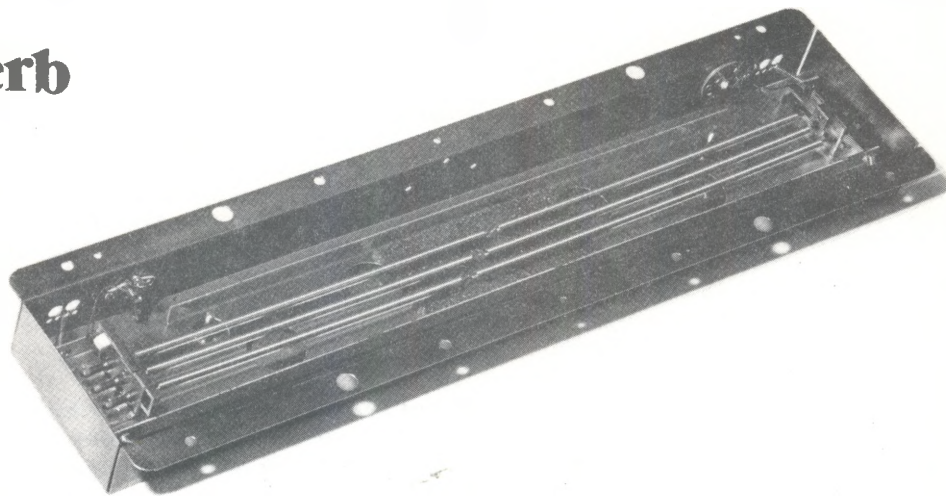

Photograph by Vesta Copestakes - CAVE GRAFIX

the tone. TAPCO packaged a similar unit, sans limiter, in its mixers and a good-sounding reverb it was (later, TAPCO put two in a rack-mount package with four bands of EQ on each channel). We'll talk about using non-limited units later.

The crowning touch on this rapid advance came when Polyphony editor Craig Anderton unveiled his "Hot Springs" reverb in the October 1980 issue of Modern Recording. It combined EQ with some of the ideas that had been floating around the guitar pickup world: series output transducers for a hotter output, parallel input transducers, and a differential "hum-bucking" boing-cancellation principle. This unit is so good, and so elegant, it should be put in a flat-black cube and major studios should be charged \$600 for it without being told what's in the black box! Yet for under \$80 (the cost of the PAIA parts kit plus power supply) the Hot Springs gives a sound that's close to the cheaper foil-type reverbs and is of course less expensive, and totally different in nature, from the digital reverb computers made by Lexicon and others.

We've covered cost and technological advances. So far, so good. Obviously if a spring reverb can survive life in a touring Fender amp, the little suckers are tough. They can certainly withstand hostile environments better than foil- or plate-reverbs and aren't as delicate as the digitals -- try the "beer test". Open a can of beer so that the spray hits the controls of a digital reverb, drink it, then repeat with any spring reverb. Continue and...oh, heck, just hurl a canful onto the springs and the computer unit for laughs. Which won?

Size is a factor that will become increasingly important as companies cram more noise into less space. Every reverb unit made takes up at least as much space as, and usually more than, a spring unit (which can be as small as one rack space complete), and springs fit well into most dual-purpose mixer packages. Perhaps some genius will develop a \$50



digital-analog hybrid reverb using a piece of gold foil the size of an 8-pin DIP inside a case the size of a cassette -- I'm sure it can be done -- but let's not wait, okay? Let's press on.

**Applications.** That's the magic word. As musical processing tends to become more digital (and we all know engineers using limiters from the 50s because they sound better -- and they do), recorded sounds will become more sterile in a certain fundamental way. Let's circle around that statement: what's inside a digital drum machine? A DIGITAL RECORDING of an analog drum. NOT a program that's creating the sounds using FFT procedures, which is too bad because musical signals of all sorts contain incredible amounts of randomness that are extremely difficult to "describe" digitally. Synthesizing some trumpet at MIT takes the resources of a computer about the size of an IBM 370 -- why not hire an out-of-work horn man? Sometimes digitizing can be more trouble than it's worth. Of course MIT is engaged in valuable basic research so they can be forgiven, but we can't expect to throw a DEC computer into our control room without taking out a second and third mortgage.

Digital units operate well only within very strictly designed parameters concerning sampling rate, bandwidth, and so on, or the hash that results is scary. This means that our sounds are losing that random, natural edge. Anyone can tell the difference between Johnny Ramone slamming his guitar strings 400 times a minute and a digital recording of one "slam" gated 400 times a minute -- the digital recording will sound exactly the same, every "stroke", whereas Johnny and his guitar form a complex cybernetic system that makes each "stroke" just a little different from any other, anywhere, ever. A Zennish analogy: you could contemplate a waterfall or a slab of Plexiglass standing on its end. Both possess beautiful, innate qualities but which is more "natural"?

By contrast, no two spring units are the same at all due to the inherent non-linearities of inexpensive resistors, capacitors, and transducers plus the differences between each and every spring made. How can we utilize this to our advantage? Most simply, we can mix spring reverb in the background of instruments like guitar and synthesizer while recording to add "body". Listen to the old Lovin' Spoonful records and you can hear springs gaily banging away on the guitars. This sort of extra musical information can be thought of as a poor man's "aural exciter": EQ the springs to a broad peak from 3 kHz to 10 kHz, and hide it back in the mix. Limited springs work well for this, but unlimited springs work best for the following unusual applications.

Dub reggae, a tremendously wild form of music from Jamaica, uses bursts of reverb and sometimes slamming reverb springs as a rhythm effect. Springs sound great in dance-dub mixes, lending an inimitable electronic texture (one that's legitimized, by the way, by dozens of 50s and 60s pure-electronic music recordings). Try it; you'll like it (the Scientific Americans do).

And back to those drum machines -- how can we "humanize" a sequencer-driven lockstep beat? Well, here are a few notions. Use springs on a signal split from your "dry" drumbox to drive effects like flangers, DDLs, ADLs, or more expensive reverbs. Mix this back in. Use an envelope follower to track

the reverb's output and use the EF output to drive any kind of modulator (such as a VCA on the electronic snare during mixdown, the PWM of your synth bassline, a noise gate keying the ride cymbal in and out of a delay or plate reverb, a delicately-adjusted Schmitt trigger that'll fire a percussion device, etc.). Think of the reverb's output as a quasi-synchrosonic control voltage generator. Why waste an EMT plate doing something like that? I used to have great luck doing this on an old ARP "Blue Meanie" 2600. Drumboxes, whether digital or analog, need all the help they can get to provide interest to the part of our monkey-brain that monitors what we hear.

As you play with a spring unit, you will discover new uses. When you think of a reverb as a very strange combination of envelope follower, sample and hold, and noise generator, you'll be on the right track. The random nature of a spring reverb's output just might become increasingly valuable as we digitize our processors -- its random phase-modulation effect can be thrown onto synth tracks, especially, to give them interest and depth. What about taking a little of everything in the rhythm section, mixing it into a spring, delaying the result to fall a beat or two later in the mix, and easing the result way back in the center of the mix -- or double delayed, mixed way back in the right channel followed by way back in the left channel...-what would that do to your electronic dance mix hit?

I hope this article has inspired you to spring into action.

## BY PROFESSIONAL DEMAND

DDC OFFERS FREE ADVICE, PERSONAL SERVICE AND ONE-DAY SHIPPING OF THE FINEST MUSIC AND SOUND EQUIPMENT AVAILABLE ANYWHERE:

**CROWN** Traynor  
**EV** KORG polyfusion  
**KELSEY** Holman  
**TEAC** Stebotuner  
**MXR** I M I  
**DiMarzio**  
**REMO**  
**YAMAHA**  
**whirlwind**  
**ROSS**  
**ASHLY**  
**intersound**

PLEASE CALL OR WRITE FOR PRICES & ORDERING INFORMATION - YOU'LL BE GLAD YOU DID!

**DDC** DICKSTEIN DISTRIBUTING COMPANY  
 1120 QUINCY PPY-SCRANTON, PA 18510  
 PHONE ORDERS WELCOME (717) 344 7469



# GATE - SAMPLE/HOLD CIRCUIT

BY: MICHAEL  
ROGALSKI

In the process of building a PAIA EK-x series-based synthesizer, I found I needed a sample-and-hold (S/H) circuit to hold my analog keyboard voltage in memory for as long as the VCA was letting the signal through. The circuit also required a gate output, since I used a keyboard lacking a set of trigger bus contacts. This article describes how to build such a circuit, which is applicable to other types of synthesizers using analog keyboard designs.

**How it works.** The control voltage coming from the keyboard feeds the inverting (-) input of one section of a 4558 dual op amp.

As configured, the input impedance of the circuit is very high, especially with respect to DC control voltages. C1, a 0.01 uF capacitor installed at the input, shunts any noise and transients coming into the input to ground. Be sure to use a shielded cable between your keyboard (or front panel patch point) to prevent false triggering at this input.

The comparator built around IC1A compares the input voltage with the voltage sampled between the two power supply points at R6, the threshold control. This control determines where the front end will start putting out the appropriate voltage swing to the

power supply rail, indicating a "gate on" condition. Since IC1A is an inverter, as well as a comparator, IC1A needs a diode at its output (D1) to pass only negative voltage swings. This voltage then goes to IC1B, which inverts once again, and rectifies only positive signals. This lights the gate LED on the front panel to show that this part of the circuit is working, i.e., the input voltage at pin 2 is more positive than the voltage present at the wiper of R6.

The gate signal comes off the junction of D2 and D3. With D3 and R4 in circuit, the gate output is +12V. Remove these two compon-

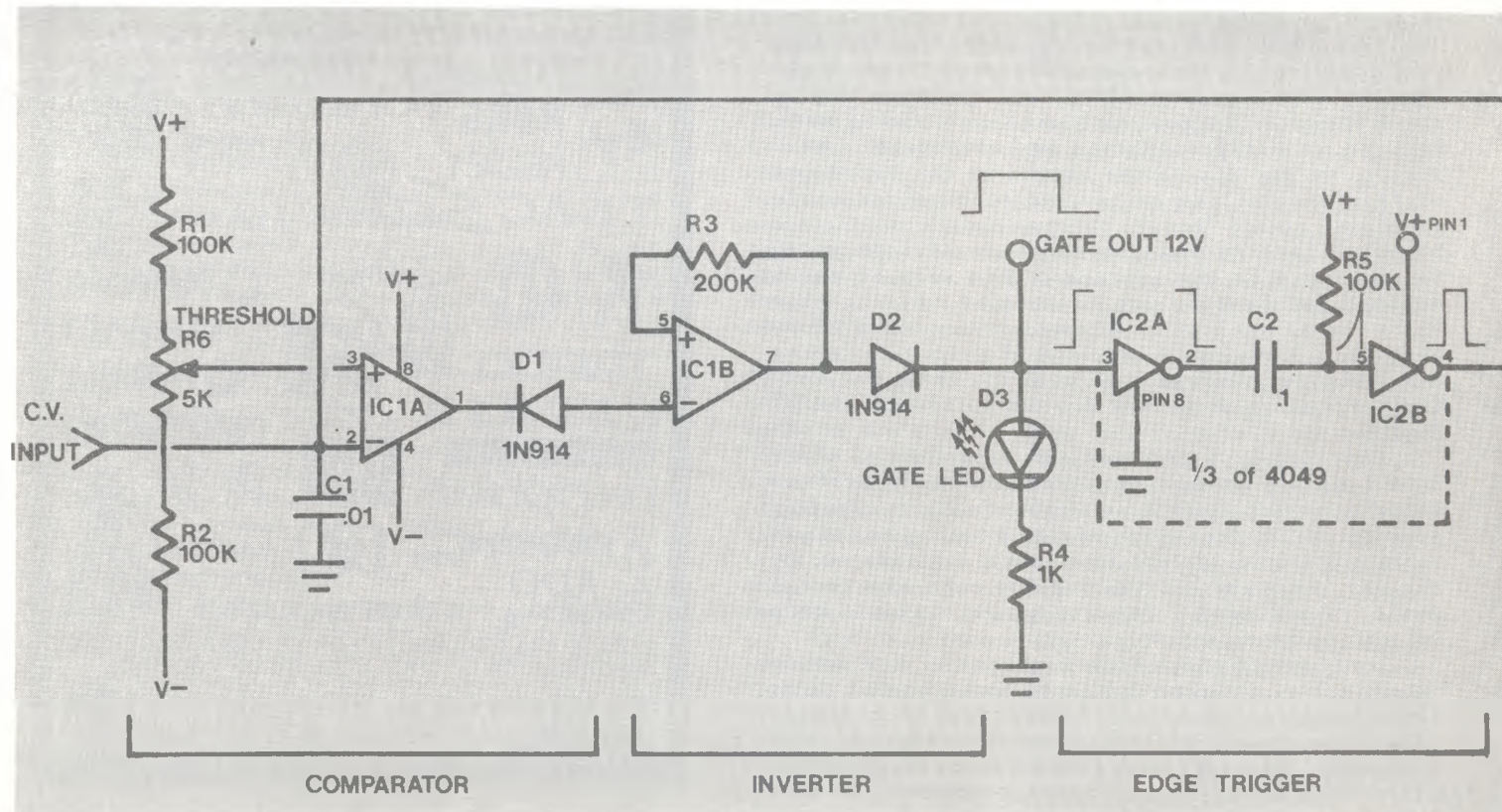



ents and the voltage will swing all the way to +15V, however PAIA EK-x circuits handle a 12V gate voltage just fine as is.

The next part of the circuitry is the edge trigger section. This takes the 12V gate swing and passes it through IC2A and IC2B, which convert the gate signal into a +15V pulse of defined width which is compatible with the sampling characteristics of a typical synthesizer keyboard. This circuit also debounces the pulse, so there is no question about the sampling voltage applied to pin 13 of the 4066 analog switch. When the 4066 switch closes for the period defined by the RC time constant of R5 and C2, IC3 samples a bit of the input control voltage, and holds it when the pulse out of IC2B drops sharply back to 0 Volts. By using a polystyrene capacitor for C3 in conjunction with a bi-fet type op amp, the "droop" of the sampled voltage will be very slight, compared to using a ceramic capacitor with a standard bipolar op amp. The importance of using a polystyrene cap cannot be emphasized enough; without the right cap, your VCOs may not play the same note each time you hit the same key, or they may drift from their proper pitch if the VCA allows the VCO signal to be audible for any length of time.

Setting up the circuit is simple; key the lowest note on your keyboard, and turn R6 until you get a reliable gate light indication every time you hit a note.

**Problems and solutions.** Now we come to some of the problems you will encounter with these types of circuits. The first problem you may encounter is not getting any gate out of the circuit. This may be caused by a voltage drift at either end of the resistive ladder comprising R1, R2, and R6. If you do not have a regulated supply feeding V+ and V- the threshold point will fluctuate, and you will end up with either a continuous gate on or no gating action at all (especially at the low end of your keyboard). Not all 15V regulators are created equal! They vary a few tenths of a Volt from lot to lot, especially when you are buying non-precision parts. You can increase R6 to "soak up" any differences, although the larger the value, the more difficult it will be to set a precise value.

Also watch polarity of all diodes (or the circuit won't work), and make sure that the control pin of the 4066 switch gets a clean pulse to turn it on and off. The circuit as shown works just fine; don't try to eliminate IC2 from the circuit or

you will get very erratic sampling. And speaking of IC2, tie all unused inputs (pins 7, 9, 11, and 14) to ground; also tie the unused 4066 inputs (pins 5, 6, and 12) to ground.

The last precaution is to make sure that your keyboard contacts are reasonably clean, and adjusted properly so as to not bounce excessively. The edge trigger circuit (IC2A and IC2B) help to clean up the input signal and square off the pulse going to the 4066, but that doesn't mean they will ignore all transients coming their way. If false triggering becomes a problem, increase C2 to a larger value, which turns on the 4066 for a greater amount of time.

**Final comments.** Construction is not critical except for the points mentioned earlier, and of course, use proper circuit board layout principles. Decoupling the op amps at each power supply point did not seem to be necessary, although this is always good practice. You might want to put the whole thing on a piece of perf-board, but if you do, leave a little extra room on the board for future projects. This will save you from having a lot of little boards all over the place, and minimize the chances of stray noise creeping into your circuitry.

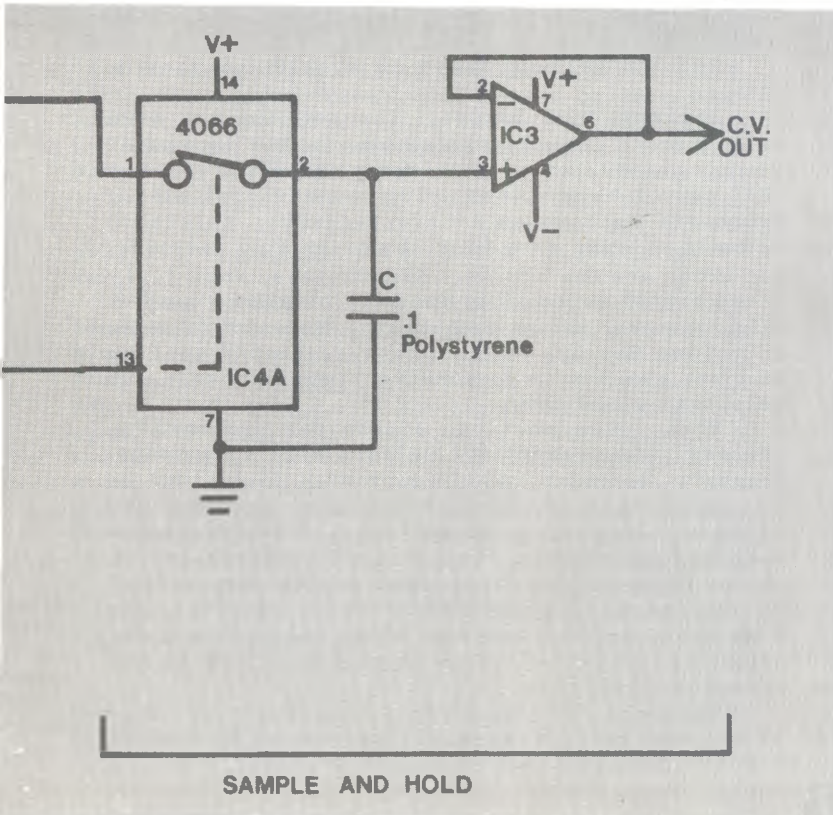

#### PARTS LIST

Resistors (precision or 5% types preferred, 1/4 Watt)

R1, R2, R5	100k
R3	200k
R4	1k Ohms
R6	5k pot

#### Capacitors

C1	0.01 µF (mylar preferred)
C2	0.1 µF (mylar preferred)
C3	0.1 µF polystyrene

#### Semiconductors

D1, D2	1N914 or equivalent
D3	LED
IC1	4558 dual op amp
IC2	CD4049 hex inverter
IC3	LF351 bi-fet single op amp
IC4	CD4066 quad analog switch

# DIGITAL DRUMS



## An Overview

By: **Craig Anderton**

The new generation of digital drums represents one of the most significant advances I've seen in the field of musical electronics for quite some time. Originally pioneered by Roger Linn (the Linn-Drum has appeared on countless records, including "Dare" by the Human League), digital drums are now available from a number of other companies as well.

Thanks to friends in the industry, I recently had the opportunity to evaluate the E-mu Drumulator (list price \$995), MXR Drum Computer (\$1250), and Oberheim DX (\$1395). Playing with these drum units has been a truly profound experience which has altered the way I look at, and compose, music. In the space of a few months, working with and programming these devices has taught me more about rhythm than I had learned in the past 20 years. As a side effect, my bass playing has tightened up as well, and I find it easier to compose songs when there's a catchy drum riff churning along in the background.

One of the most important features of the Drum Computer and Drumulator is sync-to-tape (a retrofit will soon be available for the DX which gives it sync-to-tape capabilities as well). This means that you can record a click track on one track of a multi-track tape recorder and, using the click track as a timing reference, overdub a drum part on a separate track. As the song develops, if it becomes necessary to change the drum part, you can simply re-program the drums and lay down a revised drum track. By syncing this new part to the click track, the drums will still be in sync with the rest of the song. In some cases, I've come back to a song weeks (or even months) later and programmed a new drum part which was more appropriate to the song. Also, syncing these drums up to PAIA's "Master Synchronizer" (see the February 1983 issue of *Keyboard* magazine) has allowed me to do a large number of synchro-sonic tricks, such as programming a drum part designed specifically to trigger a keyboard arpeggiator.

But I'm getting ahead of myself...so back to basics.

**Digital drum basics.** The new digital drum units record actual drum sounds on ROM (computer memory chips), which provides a degree of realism that cannot be achieved using conventional analog synthesis techniques. Unfortunately, this also means that every drum beat sounds exactly the same, but those are the breaks. Nonetheless, some judicious signal processing can help overcome some of this sameness, as can programming "accents" (changes in volume level). Note, however, that accenting does not give any corresponding timbral change...oh well, maybe next year.

These drum machines divide the programming process into segment (or pattern) and song modes. Segments represent individual riffs, fills, and so on. In song mode, these individual patterns are combined to make a complete song. For example, a verse might require four programmed segments, a chorus two programmed segments, and an instrumental break a segment which repeats over and over. In song mode, you would string these together and the drum unit would play the proper segments in the proper sequence.

When programming a pattern, you put the drum unit into "record" mode. A metronome, which is usually programmable to click at your choice of rates, lets you know where you are in the measure.



When you press the button corresponding to a particular drum sound, the drum unit "remembers" where you played that drum. As the pattern keeps repeating, you can overdub drums until the pattern is complete; you can also erase unwanted sounds. Quantization (also called auto correct) can optionally correct your timing to the nearest eighth note, sixteenth note, eighth note triplet, and so on; the Drumulator and DX even offer an additional high resolution mode, which defeats the "rounding off" off effect of quantization.

The DX is the only one of the three units that offers "step time" recording (where you can step slowly through a pattern and program, or erase, drum beats as desired) in addition to "real time" drum recording. This is very handy when you need to erase one or two drum sounds out of a complex event like a drum roll, or want to transcribe a drum part from sheet music.

These drum units also have cassette interfaces so that you can permanently store patterns and songs, battery backup so that a power interruption won't kill your stage act, and a variety of convenience features...which we'll describe in more detail as we go along.

Now for a word about the comparison checklist. The worst possible way to select a drum unit would be to add up the various features and decide that whichever has more features is the "best" drum unit. Musical instruments -- and these are indeed musical instruments -- inspire conflicting opinions. For example, while most guitarists would say that a Fender Stratocaster is a "better" guitar than a Fender Mustang, I know one guitarist who wouldn't trade in his Mustang for anything. And while I feel that certain drum units offer better fidelity of sound than other drum units, fidelity of sound is not always the same thing as appropriateness of sound. I often find myself syncing different units to the same clock signal, and using drums from one unit in conjunction with drums from a second unit. Also, these drums "print" differently on tape. Remember, the checklist is intended for comparison, not judgment; every unit makes tradeoffs, and much of how you react to a drum unit depends on whether or not you agree with the tradeoffs that were made.

Also, a checklist can't describe all of the subtleties, so let's look at some digital drum details.

**Drum sounds.** Of the three units, I feel that the Drum Computer has the most synthetic-sounding drums. However, this is neither a complaint nor a compliment. In fact, on one song I found that the MXR drum sounds fit with the piece (which was highly synthetic) better than the more realistic Drumulator and DX sounds. Both E-mu and Oberheim have gathered a lot of experience digitizing sounds over the years, and this shows in their respective products; but remember too that one of the advantages of ROM-based drum units is that sounds can be updated at a later date simply by plugging in a new ROM. In fact, the MXR Drum Computer includes an external voice connector to allow for easy expansion and/or replacement of existing sounds, and an alternate bass drum sound was included in my review unit as one possible option. (As we go to press, MXR has confirmed that a library of additional sounds will be available within a few months, and quoted extremely reasonable projected prices.) While E-mu does not

plan to offer additional sound ROMs (although a 1 second crash cymbal may be substituted for the ride sound), they have devised a process whereby Emulator owners can record drum sounds, at which point they are programmed into an EPROM. This is not a trivial process, but it is not impossible either. At present, there are no plans for additional DX voices (however, the higher-priced Oberheim DMX does accept a family of optional sounds).

One outstanding feature of the DX is that the drum sounds are individually tunable over about a half-octave range. This lets you obtain a variety of different drum sounds from one unit without having to resort to external signal processing, thereby increasing the overall usefulness of the device. The Drumulator drums are not tunable, while the MXR has a master tuning control which varies all drums about +1 full step. This is real handy when you want to tune lower for super-deep toms, or tune higher for a brighter cymbal sound. However, because (unlike the DX) we're dealing with a single control, all sounds change pitch simultaneously.

While I feel that handclaps are generally the weakest part of any digital drum set (humans just do not clap with metronomic regularity), the Drum Computer handclaps are particularly unrealistic. However, I was able to use the handclaps to get some great guiero (wood scraper) sounds. In fact, had they labelled the handclaps "guiero", I would be talking about how realistic the guiero is instead of how unrealistic the claps sound! Just goes to show...

The three tom sounds on all three units sound just fine; however, the DX will not let you play more than one tom sound on the same beat, and if you try to program the different pitched tom sounds in rapid succession, the decay of the preceding tom will be cut off by the attack of the next tom. The Drumulator also doubles up the high and mid tom, so you can't have them both hit at the same time. (All three drum units double up the hi hat closed/hi hat open sound; the Drumulator also doubles up the side-stick/snare and cowbell/clave sounds, while the DX doubles up the shaker/handclaps sounds. The Drum Computer sounds are independent of each other).

Getting a good hi-hat sound is also a problem, although in the context of a recorded track they usually sound okay. The MXR unit audibly re-triggers, the DX closed hi-hat doesn't cut off the open hi-hat (which is too short for my tastes as well), and the Drumulator hi-hat, while in many ways the best of the three, lacks the sheen you might hope for and also has a somewhat grainy sound -- although a little high frequency equalization pretty much overcomes these limitations.

The percussive voices all sound great, but extra credit to the DX for offering a shaker sound, a welcome variation from all the "struck" sounds you usually find on drum units. If you alternate between the accented and non-accented versions, the shaker makes a great background track. However, since this sound is doubled up with the handclaps, if you mix the shaker in the background you mix the handclaps back as well. The Drumulator also deserves extra credit for its cowbell. If you've ever tried to record a cowbell in the studio, you know how hard it is to get a good sound. Well, they got it.

With respect to snare drums, the Oberheim and

Drumulator snares are different yet of equally high quality. The Drumulator is little flatter and more hi-fi, while the DX sounds more processed and has a bit more of a "crack". Triggering the two simultaneously gives a very fat sound. When I heard the MXR snare isolated from the rest of the kit, I thought it sounded quite synthetic; but it fits into tracks quite well and has a more "new wave" kind of sound.

Cymbals are extremely difficult to record digitally, which means you just aren't going to get killer sustain or highs. The MXR crash, however, is quite good, as is the DX (which also has two accent levels). The Drumulator ride cymbal is fine if you like ride cymbals, but I prefer using a crash most of the time. I often trigger the MXR or Oberheim cymbal from the Drumulator ride output, and the resulting sound is excellent. I've also noticed that using a delay line, set for about 50 ms of delay and a touch of regeneration, extends any cymbal sound and gives a more natural decay effect.

**Ease of use.** I feel that the MXR and Oberheim units are the easiest to use, however, the Drumulator is more complex to use not because of poor design but because it offers more options in its software, which can require more extensive programming when creating a drum part. A good example is accents. With the DX, the snare drum has three buttons, each corresponding to a different volume level. If you want a softer snare, hit one button; a louder snare, the next button, and the third button gives the loudest snare of all. However, not all DX sounds can be accented; and some sounds have two, rather than three, accents. The MXR, on the other hand, has a single accent which can be added

to any of the 12 sounds by pressing the accent button while you press the desired drum sound -- very simple. The Drumulator has the most complex accenting scheme, where you may program any one of 14 accents for each drum. While this is a highly versatile way of dealing with accents, it can also be time-consuming to set an accent for each drum -- although, of course, you can always use the default settings if you're impatient and don't want to go to the trouble of programming accents. The biggest advantage of programmable accents is that you can have subtle accents on some drums and wild accents on others; these options are musically useful. For example, I find that percussive sounds seem to like heavy accents, while drum sounds seem to like lighter accents.

**Or take level setting.** With the Drumulator, you program the various drum levels, while with the Drum Computer and DX, you adjust mixer slide pots. I prefer programmable drum levels since once you have a good mix, you can store it and come back to it later. Yet, there is something to be said for altering drum levels in real-time, and the slide pots let you do this easily. Of course, with the Drumulator you can always program levels but also feed the individual outputs into a mixing board to vary levels in real time, but if you don't use a mixer there's no convenient way to vary multiple drum levels in real time. Again, it's all a question of personal preference.

Another difference between units is the number of buttons you use to play the drums. With the MXR and DX, all drum sounds are available at all times -- there's one button for each sound. With the Drumulator, there are four buttons for the twelve

## Digital drum machine check list

Drum sounds	DX	Emu	DC		DX	Emu	DC	
Bass drum	•	•	•	<b>Outputs</b>				
Snare drum	•	•	•		Pre-panned stereo outputs	•		•
Snare rim ("sidestick")	•	•	•		Mono mixed output	•	•	•
Number of toms	3	3	3		Master volume control	•	•	
Hi-hat open	•	•	•		Individual drum outputs	•	(2)	•
Hi-hat closed	•	•	•		Metronome (click) output	•	•	•
Ride cymbal		•			Metronome volume control	•	•	•
Crash cymbal	•	(1)	•		Programmable trigger outputs	(3)	•	
Shaker	•				Programmable song mix		•	
Handclaps	•	•	•		Programmable pattern mix		•	
Cowbell		•	•		Manually adjustable mix	•		•
Wood block/clave		•	•		Sync-to-tape	(4)	•	•
Individually tunable drums	•							
Master tuning control		•						

### notes:

- (1) A 1-second crash cymbal can optionally replace the ride sound.
- (2) Some sounds are doubled up (there are 8 outputs for 12 drum sounds).
- (3) Unlike the Drumulator, cannot be programmed to appear at specific places in a song.
- (4) Sync-to-tape will be available soon as a retrofit.

- (5) There is one trigger input which may be assigned to any drum or combination of drums.
- (6) There are four trigger inputs which must be assigned to the desired sounds. A pad programmer is slated for introduction in late 1983, with a list price of \$300.
- (7) Does not quantize to quarter note or quarter note triplets.



sounds (and twelve accented versions of those sounds), and you must assign which drum sounds or accented drum sounds you want to play to these buttons. Fortunately, the Drumulator includes an assign mode where, if you're in the middle of recording a pattern, you can re-assign different drums to these four buttons while the pattern continues. Once you exit assign mode, you can continue overdubbing with the new drum sounds. This is not as convenient as the one-sound-equals-one-button approach, but it does contribute to the Drumulator's exceptionally low list price.

All three drum units have four seven-segment LED readouts that inform you of pattern numbers and the like. The Drumulator and DX also give "beep" messages to signal that a particular operation was successful (or in some cases, unsuccessful).

**Software functions.** Software design is one of the Drumulator's strongest points. You can program individual tempos and tempo changes for each song, store a segment mix and transfer it over a song, have three different ways to end a song (unconditional end, go back to the beginning, or jump to a different song), program trigger outputs at one of several rates to occur at specific places in a song for triggering arpeggiators, or sequencers, and so on. Clearly, E-mu went light on the hardware to keep costs down but went heavy on the software to give the operator lots of programming options. The Drum Computer has fewer software functions (that's one of the reasons it's so easy to use), and the DX falls somewhere in between. For example, you set tempo with the Drum Computer manually using a slide pot (the readout can show the tempo in BPM; thankfully, any tempo changes you make will be reflected

when recording the tape sync track). With the Oberheim DX, individual patterns have programmed tempos, so when you combine them into a song the song will reflect any tempo changes you programmed into the patterns. With the Drumulator, you can store individual tempos for each song, as well as store another tempo for all the segments. You can also insert tempo change instructions during the course of a song to speed up or slow down the track.

Or how about syncing to external clocks. The DX syncs to 96 pulses per quarter note clocks, the MXR to 24 pulses per quarter note clocks, while the Drumulator includes software that lets you sync to 24 pulses per quarter note clocks or any multiple thereof.

There's so much more we could get into, but I think it's just about time to give some conclusions about the various units.

**MXR Drum Computer.** This device is extremely straightforward to use (what the computer jocks call "user-friendly"), has excellent packaging (although it is the toughest of the three to service), and is designed for easy expansion should you want to add new sounds (or update older sounds). As mentioned earlier the sound quality is to my ears more synthetic than the DX or Drumulator, yet there have been several times when only the Drum Computer made the right sounds for a particular application. The Drum Computer also records extremely well, giving a strong, punchy sound that translates well to tape. For songwriters and other people who need to get ideas down fast, this unit is probably the shortest route from what's in your head to reality. It also uses 1/4" phone jacks throughout, which makes plug-

Inputs	DX	Emu	DC	Pattern (segment) options	DX	Emu	DC
Sync-from-tape	•	•	•	Quantization	o	(7)	(8)
Sync track includes tempo changes	•	•	•	Maximum pattern length (beats)	(9)	99	99
External clock, 24 pulses per 1/4		•	•	Number of patterns	100	36	100
External clock, 48 pulses		•		Metronome (click track)	•	•	•
External clock, 96 pulses	•	•	•	Programmable metronome click	•	•	
External clock out	•			Downbeat indication	•	•	•
Individual drum trigger inputs	(5)	(6)	•	Real-time recording	•	•	•
Pitch control voltage inputs	•			Step time recording	•		
RS-232 computer control input		•		Erase individual drum beats	•	•	•
				Erase specific drum sound	•	•	•
				Erase entire pattern	•	•	•
				High resolution mode	•	•	
				Alter pattern length once set	•		•
				Swing function	•	•	
				Shift (subtle tempo randomization)			•
				Copy to another pattern	•	•	•
				Join two different segments	•		•
				Append segment to itself	•	•	•
				Accent	(10)	(11)	(12)
				Programmable pattern tempo	•	•	

(8) Does not quantize to quarter notes.

(9) Maximum pattern length is 99 measures rather than beats.

(10) Two accents for bass, snare, and crash cymbal; one accent for closed hi-hat and shaker, other sounds have no accent.

(11) Individually programmable accent for each drum sound.

(12) Fixed accent may be added to each drum sound.

(13) Each pattern will play at its programmed tempo. Changing the tempo changes all segments proportionately, as indicated on the display.

ging into mixers and such just that much easier, and you can master the operation of this device in a relatively short period of time.

**E-mu Drumulator.** If this were Consumer Reports, the Drumulator would probably earn a "best buy" designation. The sound quality is exceptionally realistic and clean (especially if you add some high-end EQ, which adds a crispness to the sound and makes it "print" much better on tape). In terms of software functions this is without a doubt the most versatile of the three units; in fact, I wish the other units had some of the Drumulator functions such as programmable mix and song tempo. Note, however, that this same versatility also makes the Drumulator somewhat more complex to operate; fortunately, the LED readout indications which "prompt" you are intelligently chosen and extremely helpful. The inability to tune the drums will bother some people, as will the use of RCA phono plugs for the individual drum outputs. But in terms of bang-for-the-buck, the Drumulator definitely delivers -- especially if you take the time to use this device to its fullest potential.

**Oberheim DX.** The ability to tune each sound over a wide range adds a degree of versatility which should not be underestimated. Also, the sound quality is excellent, and despite being a relatively complex machine, the DX is mercifully simple to operate. Having three accent levels available for the bass drum and snare is quite useful (although not being able to accent the toms can be frustrating). Remember too that the DX, like the higher-cost DMX, is specifically designed to interface

painlessly with the rest of the Oberheim "System" (OB-8 synthesizer and DSX poly seencer). The Drumulator can also be used with the "System", but requires a simple adapter box in order to be driven by the DSX sequencer. Finally, the DX has more memory than the Drum Computer or Drumulator (I counted four 6116 RAMs for the DX, as opposed to two 6116 RAMs for the Drum Computer and Drumulator), and has more available program memory as well (which means that we could conceivably see future software updates).

So which drum unit is right for you? You'll have to decide that, and hopefully this article has helped you figure out what features are most important to you. But I can promise one thing for certain: once you've played one of these babies, you won't want to let go. In fact, just as guitarists use more than one guitar to get different sounds, or keyboard players use different synthesizers because those instruments have different "sound signatures", you'll probably find yourself wanting more than one drum unit. Sure, that could be costly -- good instruments cost money, and there's no way around that. To put things in perspective, though, note that a Drumulator, DX, and Drum Computer together list for about the same as a big poly synth. And when you consider how much of a positive influence these machines can exert on your music, just about anyone would have to agree that they're well worth the price.

#### Song options

	DX	Emu	DC
Number of songs	50	8	100
Maximum # of sequences per song	255	99	100
End and repeat		•	
End and jump to next song		•	
Erase song	•	•	•
Step through song	•	•	•
Insert patterns	•	•	•
Delete patterns	•	•	•
Repeat pattern commands		•	
Copy pattern parameters to song		•	
Programmable song tempo	(13)	•	
Programmable tempo changes	(13)	•	
Start in the middle of song		•	

#### Cassette/misc. functions

	DX	Emu	DC
Load, save, and verify options	•	•	•
Number of error messages	1	1	3
Load individual pattern		•	
Check remaining amount of memory	•	•	•
LED readout	•	•	•
Memory protect	•		
Clear all memory	•	•	•
"Beep" help messages	•	•	
Minimum tempo (BPM)	25	40	40
Maximum tempo (BPM)	250	240	250
Tempo readout	•	•	•
Battery backup	•	•	•

**Special Note:** Catch the audio portion of this article in "Polyphony-on-Cassette #1". This 10 minute cassette side brings a new dimension to reviews by demonstrating the actual sounds discussed in the article. You'll hear the individual drum sounds from all three machines side-by-side for easy comparison; drum sounds are presented both by themselves and as parts of rhythms patterns. The tape also demonstrates the effects of different tunings, swing and shift functions, and accenting. The comparison closes with sample drum parts from all three drums. The other side of the tape provides an audio demonstration of Thomas Henry's "Micro-Drums" program. For your copy, send \$4.95 (postpaid in USA) to Polyphony-on-Cassette #1, Polyphony Magazine, PO Box 20305, Oklahoma City, Ok 73116. Please allow 4 - 6 weeks for delivery.



# CURRENT EVENTS

*'Tell Them You Saw It In Polyphony'*

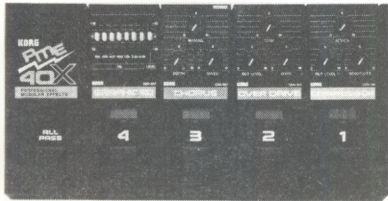

**New pedals.** MXR has introduced a new line of effects boxes, the Series 2000. Effects include the Distortion+, Dyna Comp, Phaser, Stereo Flanger, Stereo Chorus, and Time Delay. These boxes feature built-in voltage regulation, status LEDs, dual outputs, FET switching, and a unique interface connector that provides capabilities such as remote switching, remote status indication, and selection of the highest voltage power source available (when used with an AC adapter).

Korg has introduced the Professional Modular Effects 40X, a pedalboard-based system that accepts Korg plug-in effects such as chorus, flanger, compressor, graphic equalizer, fuzz, etc. The cost of four effects plus the pedalboard is comparable to that of four standard effects from competing manufacturers.

**New tape duplication process from Sony.** Sony is using metal-based, high-coercivity videotape masters to print a duplicate on to conventional tape. The master and tape to be duplicated are pressed close together with compressed air, while a high frequency magnetic bias field magnetizes the duplicate tape. This process may also be applicable to PCM or audio tape, drastically cutting duplicating time and therefore costs.

**EM Festival-on-the-Air** A regional Electronic Music Festival is scheduled for February 1984 in Sint-Niklaas, Belgium. Musicians are invited to send their music (tape, cassette, or album) to MICRART GROUP, Industriepark Noord 10, 2700 Sint-Niklaas, Belgium. Airplay is promised over several stations, with a combined listenership of about 10 million people. MICRART advises sending all music before December 18th, 1983 (preferably via Air Mail).

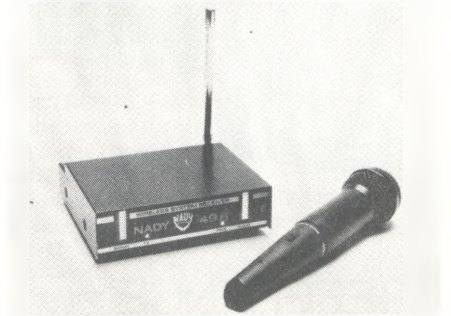

**Wireless mic.** Nady Systems (1145 65th St., Oakland, CA 94608) has introduced the 49-HT hand-held microphone. It features an Audio-Technica PR60 mic head, self-contained antenna (no dangling wires), and low cost.

**Serge sequences.** Serge Modular (572 Haight, San Francisco, CA 94117) has announced a new line of low-cost sequencers for modular analog synthesizers which features many of the same functions incorporated into the Serge 16-Stage Touch Activated Keyboard Sequencer. The 4-stage model lists for \$180 kit, \$240 assembled; the 8-stage for \$240 kit, \$320 assembled. A master unit can control one or more slave sequencers for highly controllable flurries of total sequences, being modulated both harmonically and rhythmically. The series includes 4, 5, 6, 7, and 8-stage Sequencers, and a built-in Quantizer option is available for all but the 4-stage version.

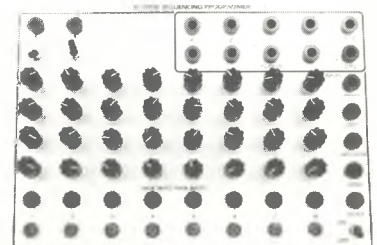

**New from Korg.** Intended for keyboards and guitar as well as line level sources, the MM-25 is a 25 Watt monitor amplifier which includes high and low EQ, headphone jack, and multi-position function switch. The KMX-8 is an 8 channel stereo mixer with VU meters and self-adjusting input impedance from 10k to 500k Ohms.

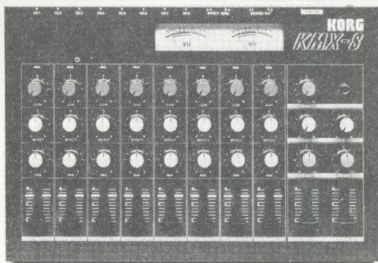

**Concert news.** The McLean Mix (an electroacoustic duo featuring Priscilla and Barton McLean) will give seven European concerts in November 1983, and will tour the US in March of 1984. For booking and tour information, contact the McLean Mix at 6 Matador Circle, Austin, TX 78746 (tel. 512-327-2729).

**Reverb decay time alteration.** The Master Room DC-2 from MICMIX (2995 Ladybird Lane, Dallas, TX 75220) allows the user to vary the decay time of virtually any type of reverb device -- spring, plate, or live chamber. The DC-2 also provides up to 30 dB of noise reduction for virtually any type of reverb.



# POLYMART BOOKS

## SCIENCE OF SOUND

The physical and psycho-acoustical background to music is an important part of musical synthesis. Helmholtz's **SENSATION OF TONE** is, a century after its publication, still the standard text for the physiological acoustics. **PSYCHOLOGY OF MUSIC** by Carl Seashore, developer of the Seashore Music Test, provides an in-depth analysis of musical style and performance characteristics of many instruments. **MUSIC, PHYSICS AND ENGINEERING** by Harry Olson, who worked on the first RCA synthesizer, is a thorough discussion of the physical properties and design of traditional musical instruments (plus a chapter on electronic music). **MUSIC, SOUND AND SENSATION** by Winckel is much like the Helmholtz work, with a bit less detail and more concentration on psycho-acoustics.

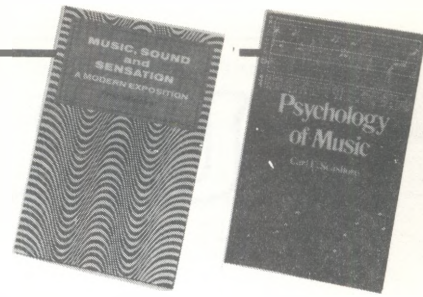
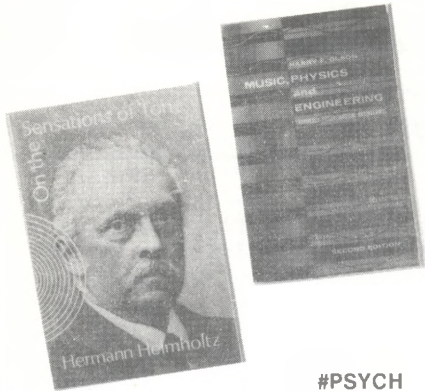

#PSYCH	PSYCHOLOGY OF MUSIC	\$6.00	#SENS	ON THE SENSATIONS OF TONE	\$9.95
#MSS	MUSIC, SOUND AND SENSATION	\$4.50	#MPE	MUSIC PHYSICS AND ENGINEERING	\$6.50

## REFERENCE

Often used reference materials to answer the many questions encountered in everyday synthesis. **THE SOURCE** Book of Patching and Programming from Polyphony has over 125 pages of patches in universal flow chart notation; the largest publication of its type. **AUDIO CYCLOPEDIA** has 1760 pages with 3650 entries and hundreds of drawings and schematics to answer any question about ratio. Hardbound. **ELECTRONIC MUSIC SYNTHESIZERS** by Delton Horn devotes the first half to descriptions and functions of commercial electronic music synthesizers (Moog, Arp, PAIA, Oberheim, EML, and RMI); the second section provides schematics and projects for the experimenter.

#SOURCE	THE SOURCE	\$4.00
#CYCLO	AUDIO CYCLOPEDIA (hardbound)	\$44.95
#EMS	ELECTRONIC MUSIC SYNTHESIZERS	\$6.95



## TECHNIQUE

Synthesists must be well versed in a number of techniques and principles. "How To" and project oriented books are a great way to pick up these skills. **MULTITRACK PRIMER** by TEAC is a step-by-step guide to building, outfitting and operating your home studio. The Byte Book of **COMPUTER MUSIC** describes computer control of electro-mechanical instruments, Fourier analysis, circuits and loads of software. **HOME RECORDING FOR MUSICIANS** is Craig Anderton's original guide to outfitting and operating a budget studio for maximum results, includes mixer and other audio processing circuits and a sound sheet demo recording.

#TEAC	TEAC MULTITRACK PRIMER	\$4.95
#BYTE	BYTE BOOK OF COMPUTER MUSIC	\$10.00
#HRFM	HOME RECORDING FOR MUSICIANS	\$11.95

## "HOW TO" GUIDES

**HOW TO BUILD A SMALL BUDGET RECORDING STUDIO FROM SCRATCH** by F. Alton Everest covers twelve tested designs. **HOW TO DESIGN TEST AND BUILD COMPLETE SPEAKER SYSTEMS** BY David Weems is a do-it-yourself guide for the ultimate in sound quality. **HOW TO MAKE AND SELL YOUR OWN RECORD** — With the major labels having severe economic problems, many insiders feel that the future of the music industry may be in independent record production. Learn the ropes with Diane Sward Rapaport's indispensable handbook of how to get started. **MAKING MONEY MAKING MUSIC** by James Dearing — Everyong dreams of being at the top, but there's an enormous amount of "middle money" out there for the taking. This is not a book about how to become a Millionaire Rock Star, but the strategies revealed will give you the knowledge you need to keep afloat if you decide to pursue a recording contract. A fresh and practical approach to staying alive in the music business. From the publishers of Writer's Digest.

#BRS	BUDGET RECORDING STUDIO	\$9.95	#MASR	MAKE & SELL YOUR OWN RECORD	\$11.95
#CSS	COMPLETE SPEAKER SYSTEMS	\$7.95	#MMM	MAKING MONEY MAKING MUSIC	\$12.95



**ORDER FROM: POLYMART, P O BOX 20305, OKLAHOMA**



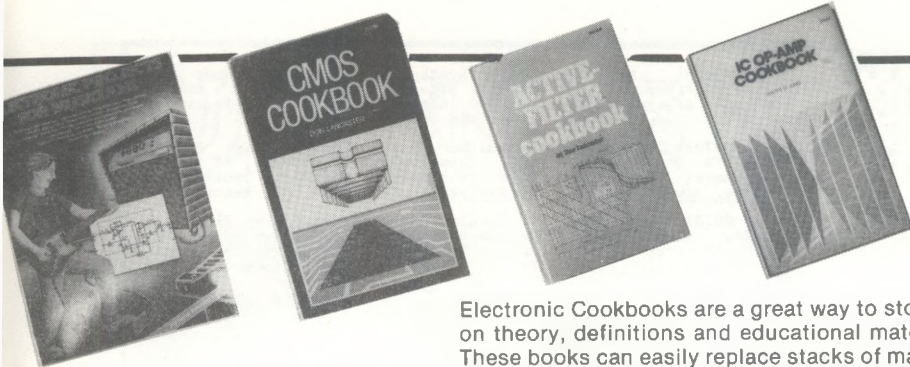

# USE THE ORDER FORM ON THE NEXT PAGE

## ELECTRONICS

Electronic Cookbooks are a great way to stock your library with materials that are not only heavy on theory, definitions and educational material but chock full of practical applications as well. These books can easily replace stacks of manufacturers data sheets and applications notes all in an easy to use reference. Walt Jung's **OP-AMP** and Don Lancaster's **ACTIVE FILTER** Cookbooks are self-explanatory — required reading for synthesists! **AUDIO OP AMP APPLICATIONS** is an edited version of the Op Amp Cookbook by Walter Jung, containing only audio applications. Lancaster's **CMOS** book is much more than a digital reference — phase lock loops, top octave generators, touch switches, and other things you need. **ELECTRONIC PROJECTS FOR MUSICIANS** by Craig Anderton is almost in a class by itself. It discusses electronic construction technique for the novice and provides 27 projects with printed circuit board patterns and a demo recording of the effects. Even if you're an old hand at musical electronics, you'll appreciate that all of these processors, from Tube sound Fuzz to Phase shifter are compatible and work together without creating noise, signal loss, bandwidth compression or any of the problems common to interconnecting effects from different manufacturers. There's even a complete chapter on how to modify and combine effects to produce your own custom pedalboard. **ELECTRONIC MUSIC CIRCUITS** by Barry Klein covers synthesizer system design, power supplies, control voltage generators, VCOs, Filters, analog multipliers and more. Lots of schematics and data sheets on the most popular music oriented ICs. An excellent technical reference.

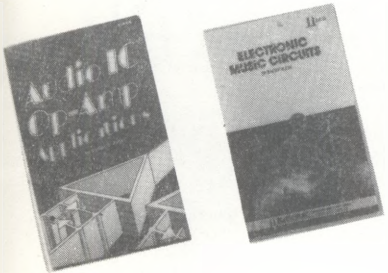

#OACB	OP-AMP COOKBOOK	\$15.95	#EPFM	ELECTRONIC PROJECTS FOR MUSICIANS	\$14.95
#AFCB	ACTIVE FILTER COOKBOOK	\$14.95	#EMCR	ELECTRONIC MUSIC CIRCUITS	\$16.95
#AUOA	AUDIO OP-AMP APPLICATIONS	\$9.95	#CMCB	CMOS COOKBOOK	\$12.95

## EXCITING NEW BOOKS!

**NEW**

**MUSICAL APPLICATIONS OF MICRO-PROCESSORS** by Hal Chamberlain — If you only have space in your library for one book on music synthesis, this is the book. The easily read text is entertaining and enlightening and teaches both basics and advanced theory without plowing through pages of equations. Liberal examples illustrate theory and practice of both digital and analog signal generation and processing.

#MAM	MUSICAL APPLICATIONS OF MICRO-PROCESSORS	\$19.95
------	--	---------

**THE COMPLETE GUIDE TO SYNTHESIZERS** by Devarahi — An extraordinarily thorough treatment of the subject of analog synthesizers. Covers everything clearly, and the suggested experiments are excellent. Well organized and leaves nothing out.

#CGS	THE COMPLETE GUIDE TO SYNTHESIZERS	\$15.95
------	------------------------------------	---------

**PRACTICAL GUIDE FOR CONCERT SOUND** by Bob Heil — Finally, a manual that explains in very simple language those many "magic terms" you've heard for years and never really understood. It's the first book written especially for musicians, roadies, and sound technicians who want to **KNOW** and **UNDERSTAND** what their sound system is all about.

#PGC	PRACTICAL GUIDE FOR CONCERT SOUND	\$10.00
------	-----------------------------------	---------

**NEW**

## & MORE FROM POLYPHONY

**4/8TRACK STUDIO LOG BOOK** designed by Craig Anderton provides a place to keep all the important information on your tape library. Log in timing, type of tape used, record patches, make notes and use the expanded track sheet to list sequential changes in tape tracks relating to the settings of the index counter. Craig Anderton's **CONTEMPORARY KEYBOARD ARTICLES** is a collected reprint of all the articles from June 1977 through February 1981, covers tips, technique, theory, maintenance, and numerous construction projects. **DEVICE BACK ISSUES** — during the year that this newsletter was published, it featured almost 200 pages of technical information for the guitarist/musician. A wealth of articles on design, product reviews, and modification and construction projects. Sold in complete set, individual issues not available. Limited number available. **CRAIG ANDERTON MUSIC TAPE** — Delightful listening plus a booklet explaining how the effects were achieved.

#SLB	STUDIO LOG BOOK	\$4.95
#AA	CRAIG ANDERTON'S CONTEMPORARY KEYBOARD ARTICLES	\$5.95
#DEVICE	COMPLETE SET (12) DEVICE BACK ISSUES	\$18.00
#CAMT	CRAIG ANDERTON MUSIC TAPE	\$5.95



**CITY, OK 73156 (405) 842-5480**



# BACK ISSUES \$ 2.50 each ppd

## Find out what you've missed!

- #0302: 11/77: The Sensuous Envelope Follower, digital gates, LED wall art, build a bionic sax, data to music peripheral project, Apple II as a music controller, using the NE566 as a VCO, patches.
- #0303: 2/78: computer controlled Gnome, using joysticks, build a bionic trumpet, ultra-VCO modifications, voltage control the Mu-Tron Bi-Phase, oral joystick, patches.
- #0304: April/May 78: Minimoog modifications, non-keyboard module use, phasing and flanging (theory and circuits), memory expansion for programmable drums, digitally addressed transposer project, polyphonic software (with software transient generators), patches, Volume 3 index.
- #0402: Sept/Oct '81: electronic music notation, notes on the recording of "Cords" by Larry Fast, sequencer software - part one, rhythmic control of analog sequencers, touch switch projects, modular vocoder techniques, PET as a music controller, patches.
- #0404: January/March 79: add-ons for vocal F and V converter, shorthand patch notation, more on note to frequency conversion, graphic monitor project, George Russell, super VCA circuit, echo software, Vol. 4 index.
- #0502: July/August 79: hex VCA/mixer project, electronic music schools and studios, modify the Oberheim Expander Module, profile of Ernest Garthwaite, budget microphones, digitizer projects and software, bar graph ICs.
- #0505: January/February 80: Joseph Byrd, Mort Garson, Larry Fast on "Games", composing for "live plus tape", using the CA3280, recording vocals, ADSR circuits.
- #0506: March/April 80: Computers in Music: real time audio processing hardware, Powell sequencer system, Max Mathews, advanced STG software, PortaStudio, phase modulation, Volume 5 index.
- #0601: May/June 80: Gary Numan, Microcomputers in Real Time Audio, Build a Digital Audio Delay Line, writing Documentation, Richard Hayman Composer/Performer Home Recording: Applying Harmonizing and Pitch Transposing Techniques by: Craig Arderton.
- #0602: July/August 80: Peter Gabriel, digital VCO project, dream modules, optimum level settings, dynamic phrasing, patches.
- #0603: Sept/Oct combined with Nov/Dec 80: alternate controllers, add voices to Casio M-10, voltage controlled quadrature oscillator project, cordless patch bay, recording rules, patches.
- #0604: January/February 81: Special Construction Edition; Build: Audio Circuit Breaker, Pulse Width Multiplier, Magnetic Harp, 50 Watt/Channel Stereo Power Amp, Quad Sequential Switch, DOD Mods, patches.
- #0605: March/April 81: Portable Music Issue, reviews of Remco's FX, E-H Mini-synthesizer, Casio's VL-Tone, plus mods for the M-10, GR-500, mini-amp, and the Korg X-911. Introducing; Practical Circuitry and On Location, new columns.

- #0606: May/June 81: Synthesizer: Hardware Mods and Software. Modular Synthesizer Effects, Environmental music, Keyboard assignment for the 8700, new columns; Details, Practical Circuitry, and On Location. Volume 6 index.
- #0701: July/August: Guitar Electronics: Modify: Fender Amp, MXR Phase 100, GR-500. Input/Output Structures, \$5 Analog Programmer, Sample and Hold technique, Modular Synthesizer Effects, new column: Applied Synthesis, Marketing Your Records.
- #0702: Sept./Oct.'81: Harald Bode Interview, Live Plus Tape - New Technique, Xenharmonics, Kraftwerk Live - Review, Psycho-Acoustic Experiments, Practical Circuitry - Super Controller, Applied synthesis - Brass, Construction Tips For Beginners.
- #0703: Nov./Dec.'81: Dave Rossum interview, Applied Synthesis: Strings, Details: Series-parallel/Sum-Difference. The Sound Gizmo and Pro-One Reviews, Practical Circuitry: VCO Deluxe.
- #0704 Jan./Feb.'82: Bob Moog interview, Chip Power - STK-050/070, Simple Square Wave Shaper, Tape Timer Ruler, Practical Circuitry: VCAs made simple, Details: Gozinda & Gozouta Revisited, Korg Trident & Casiotone 202 Reviews.
- #0705 Mar./Apr.'82: Electronic Music Math, Analog Delay Clock / Modulation; Frequency Domain Modifiers; Screen-Wave for the TRS-80; Touch Switches Revisited; Practical Circuitry: ADSR the Easy Way: Getting the most out of a Cheapo (Guitar).
- #0706 May/August '82: Anatomy of a Private record, Don Slepian Interview, Understanding Digital Synthesizers: A Digital Filter, Syn-Bow Review, Optical Audio, Profiles of SSM 2033 & 2044, The PAL Filter, Bill Rhodes Applied synthesis: Bells, Pipe Organ, Harpsichord, Electronic piano; The Realistic MG-1 Reviewed.
- #0801 Sept/Oct.'82: Ambience in Electronic Music, Tone Bypass for Fender Amps, 8 Track Reviews, Parametric EQ Tips, Solo/Cut Circuit for TASCAM Model 3, The SSM 2011, Tube Preamp, Snare + Drum Voice Circuit, Triple Pick-up Switcher, Simulated Stereo, When Quality Record Mfg. Counts, Independent Record Mfg. Convention report.
- #0802 February '83: AMS-100 Gate Output, Bus Distribution Modules for Modular Synthesizers, Dynamic Touch Controller, Expanding Envelopes, MXR Limiter Review, New Age Music, An Overview, Synsonics Drum Review, Interface, Practical Circuitry: A Patch Over Scheme for Small Synthesizers, Lab Notes: Shepard Functions.
- #0803 April '83: Sound Interface Device, Build a Bass Pedal System, Dr. Rhythm Mod., Switched Capacitance/Transversal Filters, Voltage Controlled LFO, Rockman & Voyetra Eight Reviews.
- #0804 June '83: MIDI Hardware Fundamentals, What MIDI Means for Musicians, The Vangelis Interview, Creative Recording on a Shoestring Budget, A One Chip ADSR, An Electronic Switch.

## CASIO M-10 OWNERS.....

Did you realize that your pride and joy has unseen powers? That there are voices and effects that you can add for the cost of a switch and a piece of wire? This latest booklet from POLYPHONY gives you the info that you need to transform your mini-axe and gives details on adding a "stunt box", computer interfacing and much, much more.

No. CMOD 16 pages .....\$3.50

## SSM 2011 CHIPS

As a special service to readers interested in evaluating this exciting new chip, for a limited time POLYMART offers the SSM 2011 Microphone Preamp/Level Detector IC. No. 2011 .....\$5.75 each plus postage (\$1.00)

## RACK PANEL SPECIAL!

Easily machined 1/8 inch unfinished aluminum rack panels as low as \$3.95 each in quantities of 3 or more. (you may mix sizes for discount prices)

	Quantity	
	1	3 or more
single size - 1-3/4".....	\$5.25	\$3.95 each
double size - 3-1/2".....	\$9.25	\$7.95 each
triple size - 5-1/4".....	\$12.95	\$11.95 each

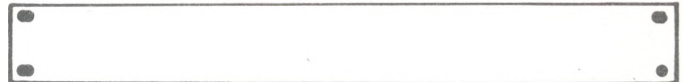

## ORDER FORM

We cannot invoice; payment must be enclosed with your order there is a flat \$.50 handling fee per order plus postage costs. MasterCharge and Visa are welcome. (\$10.00 minimum charge). Foreign orders **must** be paid by certified check or money order in U.S. \$ drawn on a U.S. bank (or by charge card) Phone orders welcomed for charge card orders.

### SHIP TO:

Name: \_\_\_\_\_  
 Address: \_\_\_\_\_  
 City \_\_\_\_\_ State \_\_\_\_\_ Zip \_\_\_\_\_



Card # \_\_\_\_\_  
 MasterCharge Bank # \_\_\_\_\_ Expiration Date \_\_\_\_\_  
 Signature \_\_\_\_\_

Quantity	Item	price ea.	amount
<input type="checkbox"/> SUBSCRIPTION <input type="checkbox"/> U.S. \$12/YR. <input type="checkbox"/> FOREIGN \$14/YR.			

Shipping Charges  
 U.S.: add 10% of SubTotal  
 or \$5.00 maximum  
 Foreign: 20% of SubTotal  
 or \$10.00 maximum

sub total	
handling	.50
shipping	
total enclosed	

**MAIL TO: POLYMART, P O BOX 20305, OKLAHOMA CITY, OK 73156**



# CURRENT EVENTS



**Oberheim power amp.** Oberheim Electronics (2250 South Barrington Ave., Los Angeles, CA 90064) has introduced the Model 700 stereo power amp. Pertinent specs are 200 Watts RMS per channel into 8 Ohms or 350 Watts RMS into 4 Ohms, THD 0.1% from 20 Hz to 20 kHz at full rated output, hum and noise 104 dB below rated output, and no fan for quiet operation. Net weight is 31 lbs; Oberheim also claims reliability under exceedingly adverse conditions (such as overloading the input of one channel with the full output of the other channel -- in other words, applying 150V p-p to the input!).

PAIA's new series V keyboard controllers have so many standard features and options available that they have been termed Universal by their designer, John S. Simonton, Jr.

Standard features include Pitch and Modulation Wheels, Gate and Re-trigger outputs, Low Note Rule Priority and Pratt-Read Keyboard actions. The controller's trim size takes up little space in the studio and their light weight allows them to be worn on stage for hours without fatigue.

The long list of options available for the Series V includes 37 or 61 note actions, Exponential or Linear Control Voltage Outputs, MIDI or Parallel Digital outputs and Mono or Poly configurations. The controllers are available factory assembled or in easily

assembled kit form with prices starting at less than \$180. Detailed descriptions, prices and ordering information are available from the manufacturer: PAIA Electronics, Inc., 1020 W. Wilshire Blvd., Oklahoma City, OK 73116.

**Digital delay.** ADA (2316 Fourth St., Berkeley, CA 94710)

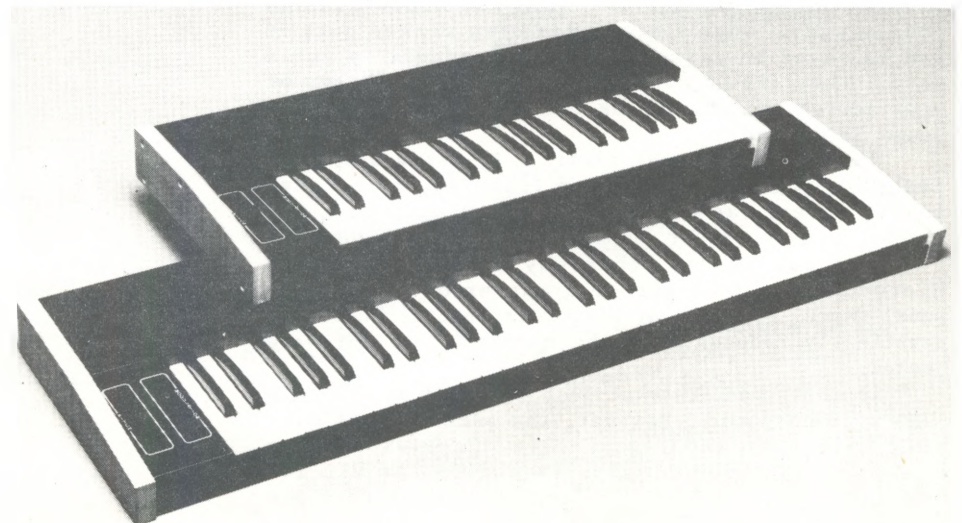
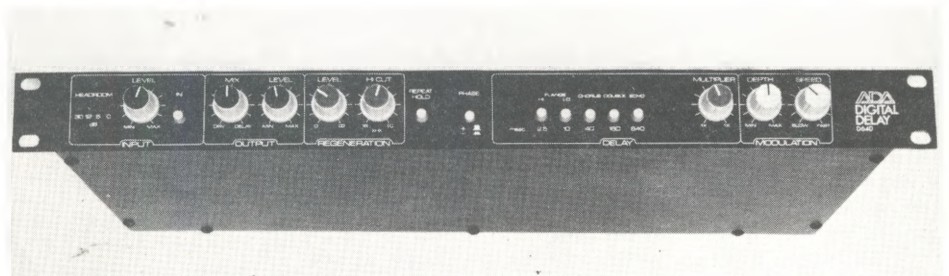

has introduced the D640 digital delay, which provides 0.25 ms to 640 ms with a 15 kHz bandwidth. Flanging range is 10:1; LFO range from 25 seconds per cycle to 10 Hz. The D640 fits one standard rack space and lists for \$499.95.

A new catalog of precision tools and computer and telecommunication equipment is being offered free from Jensen Tools, Inc.

Illustrated in full color, the 160 page catalog contains more than 2,000 tools of interest to field engineers, technicians, computer and telecommunication service persons, and electronic hobbyists.

Major categories covered are: test equipment,, micro-tools, soldering equipment, tweezers, screwdrivers, cutters, drafting supplies, power tools, computer accessories, circuit board equipment and misc. Also included are many new products from Jensen and over 40 pages of service kits and tool cases for electronic specialists and technicians.

To obtain a free copy, write Jensen Tools, Inc., 7815 S. 46th St., Phoenix,, AZ 85040 or call (602) 968-6231.



# Practical Circuitry

## MICRO DRUMS

### PART I

By: Tom Henry

Analog design has always fascinated me, and as a consequence I've never really gotten into digital or computer type circuits. However, just recently I dipped into this field and was amazed at the things that even a novice (like myself) can get a computer to do. As my first venture into this area, I came up with a computer controlled drum unit, called "Micro-Drums", which has absolutely revolutionized the manner in which I approach composition. Not being a drummer, my music has always been hampered by a lack of rhythmic expression, but this new circuit has changed all that.

What is Micro-Drums? Quite simply, it is a hardware/software combination which causes the PAIA 8700 microcomputer to think that it's a drummer. Up to eight drums can be polytonically controlled, over the range of an entire song. Nuances, bridges, breaks, lead-ins, even mistakes can be programmed into it so that the unit really drums as if it were a person. Depending on various factors, three to ten minute songs can be programmed with a great amount of depth and variation.

Editing a drum score is quite easy since an hierarchical approach is taken which closely approximates the manner in which you would write a song anyway. Once a score has been worked out, it can be saved to cassette and re-loaded at a later date. Thus, it is possible to create a library of drum scores and this eases the task of creating new songs later on.

But here's the real kicker. By using a special technique with the computer (the IRQ, to be discussed later), we can sync the drum unit to click tracks on tape, other rhythm generators, sequencers -- or we can go the other way around! That is, Micro-Drums can be either a master or slave with equal ease. And best of all, this special technique drastically reduces both the hardware and software needed.

As mentioned, this project is based on the PAIA 8700 microcomputer. However, the same methods will work with just about any other computer using a member of the 6500 family, including the VIC-20, Commodore 64, and PET. As long as you can find one



figure 2

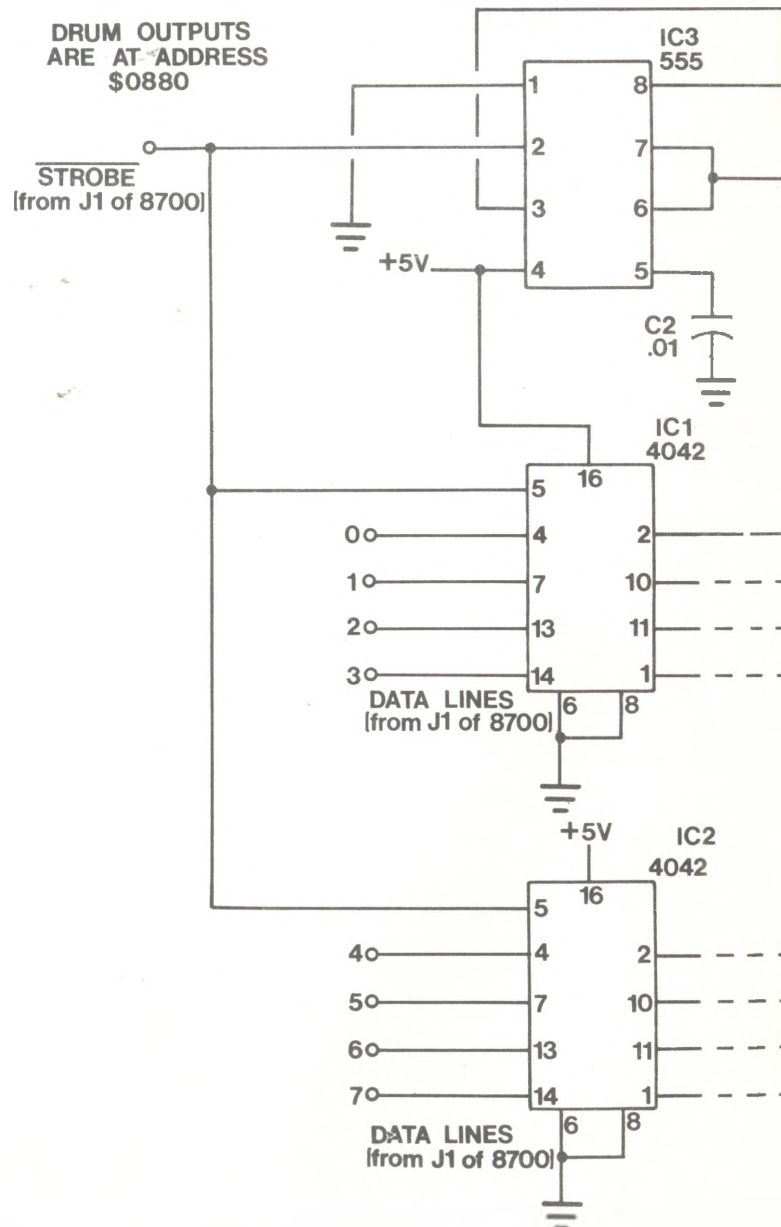



uncommitted address and can get access to the  $\overline{IRQ}$  pin of the CPU chip, you can make it work. By the way, if you do configure this around the 8700 you'll be glad to know that the new hardware in no way interferes with the rest of the computer. You can still use it for your other applications.

Like most computer projects, the basic principle is simple although the explanations get quite long-winded. To keep things orderly, this installment of "Practical Circuitry" details the hardware needed for Micro-Drums, while next time the necessary software and programming instructions are described.

Refer to the schematic in figure 1. Essentially, we set up one address in the 8700's operating system to act as a drum output port. This port is

memory mapped, and each bit in it controls a separate drum. Writing a byte into this port triggers the drums corresponding to the various bits. Address \$0880 ("\$" means that the number is in hexadecimal notation) is chosen for the drum output port, since this leaves the one at \$0840 free for other synthesizer applications.

IC1 and IC2 are quad latches; their duty is to store the byte which is written to the drum port. Since a typical "write" operation on the data bus is only several microseconds long, we need these two chips to grab the desired byte and hold on to it.

When a "write" occurs, the  $\overline{STROBE}$  line of the 8700 goes low for a microsecond or two. This line goes to pin 5 of each of the latches, hence causing them to latch the bytes currently on the data bus.

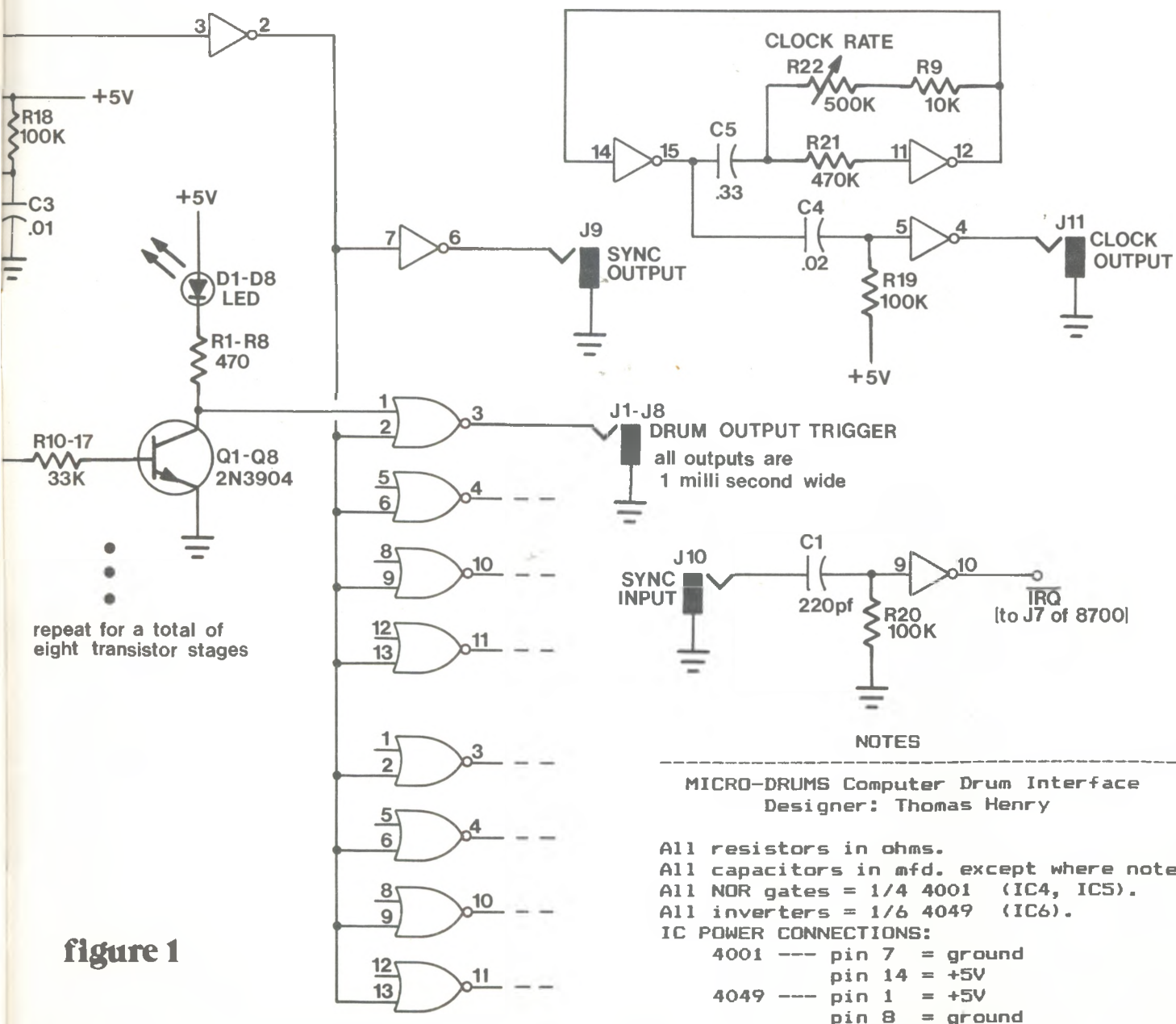

## Practical Circuitry.....

But the STROBE signal also goes to IC3, which is a 555 timer set up as a one-shot. The output of this one-shot, upon being fired, goes high for a period of 1 millisecond. In effect, we have stretched out the STROBE signal (which is several microseconds long) to a 1 millisecond pulse. You will recognize this figure as being one of the standards we've talked about previously -- it's just the right length of time to fire envelope generators and drum circuits. In point of fact, every output in Micro-Drums generates a +5V, 1 millisecond wide pulse, and thus the circuit is compatible with any of the projects described in "Practical Circuitry".

By the way, notice how everything works out conveniently for the 555 input at pin 2. Normally, you have to provide some input conditioning to this pin, but as it turns out the STROBE signal from the 8700 has the correct polarity and pulse width so that all you have to do is just hook it up directly to pin 2. That ought to refute Murphy's Law!

Now backtrack just a bit to the latch outputs. Each output is buffered by a transistor (Q1 through Q8, one for each bit). Note that the transistor inverts the bit; however, the NOR gate following the transistor inverts the bit again. The net effect is that the bit passes to jacks J1 through J8 exactly as it was written to the drum port. To put it another way, write the number \$FF to the drum port and all of the drums will be fired; write a number \$00 to the port, and none of them will be fired.

Note that LEDs D1 through D8 turn on according to the number written to the port. These provide an excellent indication of what's going on while you're composing a song.

So, the latched data is sent to the transistors and then to the NOR gates. Now one input of each NOR gate is tied to the stretched out STROBE signal (from IC3 and the inverter). This causes the selected NOR gate to go high for a period of 1 millisecond, and as mentioned above, this is just what envelope generators and drum circuits like to see.

Notice that the stretched out STROBE signal is also available at J9. This signal may be used as a SYNC output and can lock sequencers, rhythm generators, and other computers to the main timing logic. Its pulse width is also 1 millisecond.

This takes care of the drum output support hardware. As you can tell, there really isn't very much to it, and in fact it is quite similar to the other output port at \$0840 on the 8700. The rest of the circuitry in figure 1 has nothing to do with the drum output, but instead provides the necessary housekeeping circuitry to round out the complete system.

Let's look at the peripheral circuitry. Since we will be syncing the computer through its IRQ line (interrupt request), we must condition this input somewhat. J10 gives us access to this line. C1, R20, and the inverter form a half-monostable and as such take an input pulse of variable length and transform it into a precise 10 microsecond trigger. This trigger couples to the computer via IRQ, found at J7 on the 8700.

Why should this be a 10 microsecond pulse? The answer to this lies in the nature of the IRQ line in general. When the IRQ line of the 6503 CPU is brought low, the computer will cease whatever it is doing and jump to the service routine pointed at by

the vector in location \$0FFE and \$0FFF. Control is then sent to this service routine, and the instructions found there will be executed until an RTI (return) command is encountered. Control is then sent back to the main program.

Now suppose that the IRQ signal which caused all of this to happen is still low. (In other words, the execution time of the service routine was shorter than the pulse width of the IRQ signal.) What will happen? Just what you would expect; the routine is called again! The upshot is that one IRQ signal caused the service routine to be called twice. We clearly don't need that, so the IRQ pulse is shaved down to 10 microseconds. With the 8700, 10 microseconds corresponds to about 5 program instructions, so as long as the service routine is more than 5 instructions long, all will work well. Incidentally, it should be clear that the IRQ pin responds to "levels", not "edges".

As you will see next time, when we discuss the software aspects of Micro-Drums, this IRQ business is the key to the entire system. Not only does it make master/slave relationships possible, but it also allows use to achieve a remarkable analog to digital conversion for the price of a patch cord! And as mentioned before, both the hardware and software can be drastically simplified.

The remaining three inverters of the 4049 package are put to use as a variable clock. There's nothing clever here since this circuit has been around for years. But one interesting aspect is that C4, R19 and an inverter are set up as another half-monostable. This time the pulse width is made to be millisecond wide (our old standard). R23 sets the clock rate, and with this control the output frequency can be continuously adjusted. Even though the frequency can be changed the pulse width will remain fixed at 1 millisecond.

Just to give you a sneak preview, a patch cord will be used to connect the CLOCK OUTPUT (J11) to the SYNC INPUT (J10), and thus interrupts can be made to occur at an adjustable frequency. This method will be employed to set the tempo of the song.

This just about covers the hardware aspects of Micro-Drums, but perhaps a few words about construction methods should be said. I built this circuit on a prototype circuit board (from Radio Shack), using ordinary hookup wire. If you employ this method, be sure to ponder the layout so that you won't run out of room at a crucial moment! Watch your power supply connections, but since the circuit only uses a +5V supply, this shouldn't provide any great problem. Also (need I say it?), use sockets, since this project employs CMOS integrated circuits which can be damaged by static electricity. Figure two shows the complete parts list for Micro-Drums.

After constructing the circuit, give a great deal of thought on how you will interface it with the computer. I used ribbon cable and headers to complete the connections to J1 and J7 on the 8700. After making the connections I mounted the board to the back of the 8700 computer itself. If you already have this computer, then you will know that it is a double-decked circuit board arrangement. By adding the Micro-Drums card, you will be left with a triple-decked affair.

And now is as good a time as any to mention a modification to the 8700 that you really ought to



## Practical Circuitry.....

think about. I found that with just the bare-bones computer (no Micro-Drums added on), the power supply ran extremely hot. I took some measurements and discovered that the unit was drawing almost 900 mA! This is clearly way too much for the 7805 regulator to handle with such a small heatsink. The culprit, of course, is the RAM -- each chip consumes almost 70 mA. Multiply that by 8 (the number of 2112s in the 8700), and you've got quite a load for the regulator to handle.

In general I like to have at least a 2:1 margin of safety, so I decided to modify the computer accordingly. I simply built another +5V power supply and put the RAM on their own circuit. It's a crazy scheme, I know, but it does work and both power supplies now run considerably cooler. What's more, in the future I will be able to add on extra circuitry since I have a little more juice to play with now.

If what I've said doesn't make any sense to you, then don't perform the modification!!! Your 8700 is a valuable instrument and you won't want to wreck it. On the other hand, if you understand about power supplies, decoupling, and computers -- and if you have a steady hand for cutting PC board traces -- you might want to give this a try. Remember, the RAMs must be completely on their own circuit; it's no good just wiring two power supplies in parallel (unless you get off on rampant destruction of valuable equipment and enjoy fireworks).

After building the Micro-Drums card and performing the modification (if this applies to you),

you can then put the thing in a suitable house. figure 2 shows how I did it.

This is a home-made wooden box with two sheets of steel for a top and bottom. The 8700 is bolted to the top panel, and the keyboard shines through a square hole cut in the metal. I put some foam rubber around the hole and this keeps dust and moisture out. By the way, the fuse, switch, and line cord are on their own small panel mounted on the back surface of the box.

If you are using the PAIA 8700 power supply, then bring out the 60 Hz signal output to a front panel jack as well. (This is a logic level signal, NOT the line voltage!!!) Since this is a reliable frequency source, it might come in handy for future use.

As you examine the photo fig. 2 you will probably notice some features not described in the article (knobs, connectors, etc.). These have nothing to do with the Micro-Drums interface. For example, there are two D-25 jacks on the right side; one of these is a dummy (for future expansion) and the other is an interface to my keyboard synthesizer. When you build your unit, you might like to plan for the future, too, and leave some extra room for more connectors and whatnot.

Well, that wraps up the Micro-Drums hardware and it's a good thing too, since we're out of space. But come back next time for the concluding episode and see how to implement the software for a complete drum computer. Until then, here's a challenge for you to ponder: how would you create a real time clock using the SYNC input, the 60 Hz output, a patch cord, and a bit of software?

## re-view

continued from page 9

front-to-rear as well as left-to-right. This 3-dimensionality makes his heavily-produced electronic pop tunes a listening experience which goes beyond their significance as pop tunes. Other influences might be Zappa and Godley/Creme.

Berlin **Pleasure Victim** (Geffen 2036). I didn't want to like this group -- their music is too trendy and their videos have been a little pretentious. But after having played the record numerous times looking for a weakness to attack, I have to admit it grew on me; Terri Nunn's voice has a cloying innocence and John Crawford's and David Diamond's synth backing is very professional. It's well defended from sharks like me.

Men at Work **Business as Usual** (Columbia FC37978); **Cargo** (Columbia QC38660). MAW has been called "the Velveeta of pop". However,

it's precisely because their strong, well-crafted tunes appeal to even a jaded old reviewer that they're selling so many records. Despite the cheese.

Deckard/Cardwell/Vosh **Sound** (cassette). "Sound" is what it's all about, as this synthesizer trio spins long, introspective pieces full of original synthesizer sounds. Sounds that soothe, sounds that startle, sounds that bounce off the wall and refuse to leave -- always the devotion for The Sound. \$4 postpaid from David Vosh, 6300 Goldenrod Court, Upper Marlboro, MD 20772.

Everfriend **Key Essentials** (cassette). Keyboard artist Bill Rhodes displays his skills, from Keith Emerson-like classical rock to piano fusion jazz to the dramatic "Life and Death of a Star" (reviewed May/June '81 as an EP). There's a couple vocal numbers too -- too bad the vocalist he chose sounds a little tentative. Never mind; the rest is top drawer. Contact Bill at 1 Windemere Rd., Piscataway, NJ 08854.

continued on page 44



The new Series V Digital/Analog Keyboard Controllers from PAIA offer enough standard features and options to fill every need from stage to studio. Standard features include Pitch & Modulation Wheels, Gate and Re-trigger outputs, Low Note Rule Priority, Smooth Pratt-Read Action, Light weight and only 2" high.

You have your choice of:

- 37 or 61 Note Actions
- Exponential Or Linear C.V.
- MIDI or Parallel Digital
- Mono or Poly
- Factory Assm. or Low Cost Kits

Best of all, prices start at less than \$180

**call our toll-free line**

**1-800-654-8657**

9AM to 5PM CST MON-FRI

**for price & ordering details  
& get your free PAIA catalog!**

Direct mail orders and inquiries to: Dept. 11 y

**PAIA Electronics, Inc.**

1020 W. Wilshire, Oklahoma City, OK 73116 (405)843-9626

# Build:

# A Simple Drum Synthesizer

By: Doug Young

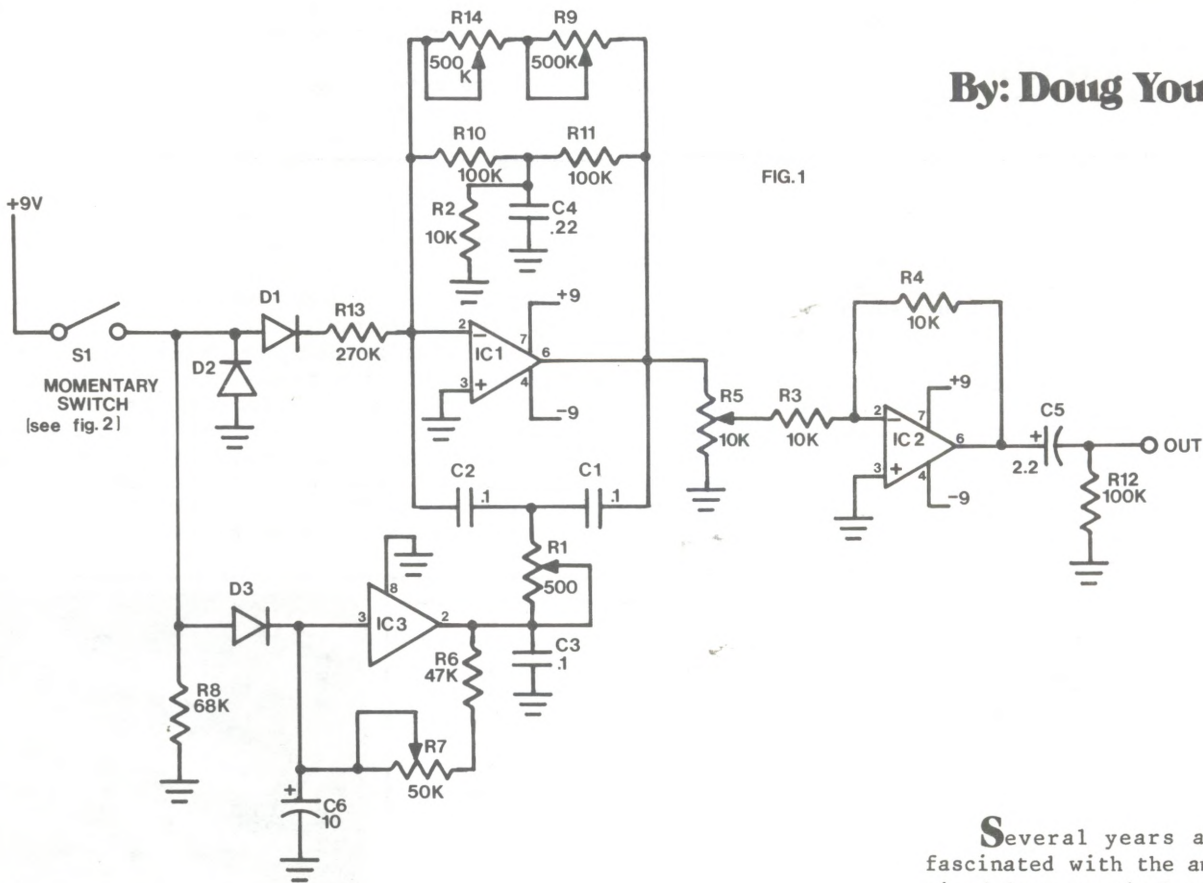

DRUM PAD DIAGRAM  
FIG. 2

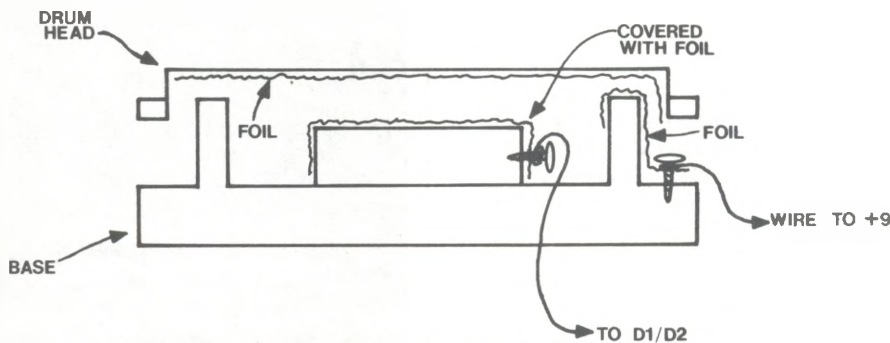

Foil on edge of base contacts foil under head.  
Attach switch wires with screws.  
Experiment with wood block size so switch closes with a moderate hit.

Several years ago I became fascinated with the analog synthesized drum sounds I was hearing on records. At that time commercial units were expensive, so I decided to build my own. Now, analog drum synthesizers are commonly available in almost any price range, but I have yet to see one as cheap and simple as mine. If you want a basic electronic drum sound with no frills at a minimum cost -- here it is.

This circuit makes use of an active filter's transient response to produce the sound. This is a circuit commonly used in older rhythm boxes. Lengthening the decay time and adding a pitch sweep produces a basic drum synthesizer sound.

The circuit is simple and construction is not at all critical. Parts values are pretty flexible too, so you can probably build it with parts on hand.



**How it works.** IC1 and IC2 are common 741 type op amps. I used a 4136 and built three separate drums on one board, with IC2 acting as a mixer for the three drum sounds; however, the schematic in figure 1 shows the pinout for 741-type amps. To mix in additional drums, feed the drum outputs into the inverting (-) input of IC2 through additional volume controls (R5) and 10k resistors (R3).

IC3 is one-sixth of a 4049 hex inverter, and is used as a voltage controlled resistor. Note that power is not applied to the 4049. Remember too that this is a CMOS chip, so observe proper handling procedures.

**Testing.** Once the circuit is wired, set R1 for minimum resistance and R7 for maximum resistance. Apply power and connect the output to an amplifier (the circuit will also drive high-sensitivity earphones directly). Turn up the volume with R5. Now set R9 to maximum and adjust R14 until the circuit oscillates; next, back off on R14 until the oscillation just stops.

Now press switch S1 and experiment with the controls:

- R9 controls the decay (length of the tone)
- R1 controls the pitch
- R7 controls the sweep rate, and
- R5 controls the volume.

The range of the pitch control is a bit narrow and the sweep range suffers at lower pitch settings. If you want a different pitch range, experiment with C1's value.

You can use any momentary switch for S1, but in my model I used a Remo practice drum pad (the kind with a real drum head on it) for S1. See figure 2. I glued aluminum foil to the bottom of the drum head, and another piece of foil to a block inside the practice pad. Connect the switch wires to each piece of foil with a screw. When the head is struck by a stick the pieces of foil contact each other, thus closing the "switch" and triggering the drum.

Although this circuit doesn't give touch sensitivity, noise, upward sweep option, LFO, or similar extras, the basic drum sound is as good as most analog commercial equivalents. My drummer has been using it six nights a week for two years now, and it works great. I hope it works as well for you.

## Parts List

Resistors (10%, 1/4 Watt except as noted)

R1	500 Ohm pot
R2-R4	10k
R5	10k audio or linear pot
R6	47k
R7	50k linear taper pot
R8	68k
R9	100k linear taper pot
R10-R12	100k
R13	270k
R14	500k trimpot

Capacitors

C1	0.05 to 0.1 uF (see text)
C2-C3	0.1 uF mylar
C4	0.22 uF mylar
C5	2.2 uF electrolytic
C6	10 uF electrolytic

Semiconductors

D1-D3	1N914 or equivalent diode
IC1, IC2	741 op amp (see text)
IC3	4049 CMOS hex inverter

## Electro-Harmonix Digital Delay



The new Electro-Harmonix Digital Delay is the first offering by the newly reorganized E-H, and if they continue in this vein the company will really give the Japanese something to worry about.

First of all, this is the smallest long delay unit I've ever seen—you don't even need a rack for it. Secondly, because it has such a long delay time, which can be used to store sounds and play them back, you have, in essence, a "Fripp-in-the-Box," if you will—meaning that you can use this box to stimulate the tape loop effects that have made Mr. Robert Fripp famous, without two tape machines. Because you have such a long time between the time you play and the time it comes around again (from eight to sixteen seconds, maximum), you can sound like more than one player at any given moment.

As a matter of fact, one of the important functions of the E-H digital delay line is to overdub yourself live using the freeze function that takes whatever is in the "circuits" at the time and stores it. Then it plays it back right away. So you can

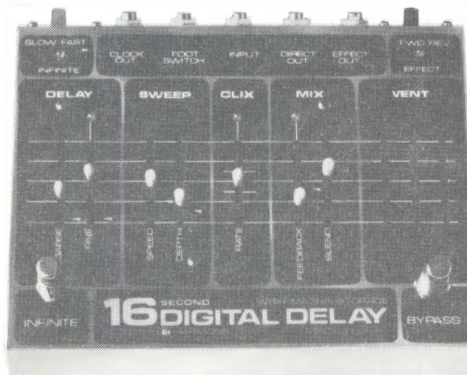

dub over that part, and layer it up. The designers have included a click track that you can hear, but which doesn't get recorded, to allow you to synchronize yourself. This unit also interfaces to the E-H line of deluxe rhythm boxes (and perhaps to some others) so that you can automatically sync the repeats to the tempo.

The E-H Digital Delay is also capable of producing a digital flange, which I like a lot. In sum, there is a lot that you can do with this unit, and in traditional E-H fashion it is priced at a half or a third of any similar unit. The unit is quiet, easy to use and easy to stow away in a shoulder bag.

—Peter Mengozio  
March, 1983/Guitar World

The Digital also contains:

- DIGITAL CHORUS which can be used at the SAME TIME as the delay and flange.
- REVERSE SWITCH—Not only can you lay down up to a 16 second track, but with the flick of the reverse switch everything you played will instantly play BACKWARDS without losing a beat. And, you can then lay forward tracks on top of the backwards track—all while you're playing LIVE!
- DOUBLE SWITCH—Anything you lay down can play at half or double speed. And—you can lay down a normal speed track on top of the halved or double speed track—while you're playing LIVE!!
- You can sing through the Digital, laying down multiple harmonies on top of each other each time the unit passes through its 16 second cycle where it instantly starts looping at the beginning again—all without losing a beat—all while you're playing LIVE!!!
- You can invent a gigantic variety of unusual new sound effects of your own with combinations of settings.

Try the 16 Second Digital Delay at your favorite music store. If they don't have it in stock, they can get one shipped within 24 hours.

Mike Matthews  
Electro-Harmonix

27 West 23rd Street  
New York, N.Y. 10010  
(212) 741-1770

electro-harmonix

# Exploring

# Just Intonation

---

---

**By: David Doty**

---

---

The tonal resources of 12 tone equal temperament have been exploited to, and perhaps beyond, their logical limits. Fortunately, there are many alternatives to this standard; perhaps the most promising of these is Just Intonation.

**What is "Just Intonation"?**  
This terms applies to any tuning system in which all of the intervals may be represented by ratios of whole numbers, with an implied preference for the simplest ratios that are musically useful. Simple whole number ratios have been recognized as determinants of musical consonance since ancient times. Modern psychoacoustic research seems to indicate that the human auditory processing mechanism is readily able to recognize these ratios and make distinctions among them which have tonal implications.

Equally tempered intonation, in general use in the West since the 18th century, sacrifices these simple ratios in order to achieve the greatest facility for modulation and transposition within a finite set of tones. The result is a scale in which all consonant intervals, with the exception of the octave, are mistuned to varying degrees.

For those interested in the mathematical concepts behind that last statement, the division of an octave into equal parts, which is necessary for transposition of any figure to any scale degree, is mathematically incompatible with division of the octave into the most consonant intervals, which are necessarily unequal. In order to divide an octave, which has a frequency ratio of 2:1, into  $n$  equal intervals, we require as a factor the  $n$ th root of 2 ( $\sqrt[n]{2}$ ), an irrational number. For 12 tone

equal temperament, this factor is the 12th root of 2 (approximately 1.05946). To obtain 12 equally spaced tones, you pick a starting frequency and multiply it by this factor to find the frequency of the next note of the scale. Multiplying this next note's frequency by 1.05946 gives the next note of the scale, and so on. Every interval in the conventional 12 tone equal tempered scale involves this factor, and therefore cannot be a simple whole-number ratio.

The ideal system of just intonation can be envisioned as an infinite space, possessing an infinite number of dimensions, each dimension being generated by a ratio of the form  $P/2^a$ , where  $P$  represents a prime number, and  $2^a$  the highest power of 2 less than  $P$ . All actual systems of just intonation can be regarded as subsets of this ideal system.

The first prime number, 1, expressed in the form 1/1, represents the starting point in any system of just intonation. (For the sake of clarity, when ratios are used to represent tones they will be underlined.) For practical purposes, it can represent any selected frequency. This ratio also represents the unison, the simplest possible interval.

The next prime, 2, generates the octave ( $2/1 = 2/2^0$ ). Multiplying or dividing the frequency of a tone by the successive powers of 2 generates only tones related by octaves. Therefore 2 alone cannot generate a musically useful scale.

The next prime, 3, generates the interval  $3/2$ , the "Perfect Fifth". Three is the lowest number which can be used to build scales. That is to say, it can be used to fill an octave with different tones. Scales which use only  $3/2$  (and/or its inversion  $4/3$  -- two intervals whose sum is  $2/1$ , or one octave, are considered inversions of one another), and  $2/1$  as generating material are called 3 limit scales, meaning that they contain no prime factor greater than 3. They are the oldest known just scales, and the easiest to tune by ear. Known as Pythagorean scales, they are generated by tuning a succession of  $3/2$ 's (or alternate  $3/2$ 's and  $4/3$ 's). Chart 1A illustrates this method of tuning a Pythagorean diatonic scale. This scale is characterized by pure 5ths and 4ths ( $3/2$  and  $4/3$ ), dissonant 3rds ( $81/64$  and  $32/27$ ), and dissonant 6ths ( $128/181$  and  $27/16$ ). There-



fore, these scales are suited for polyphony based on the 4th, 5th, and octave, but are useless for tertiary polyphony or triadic harmony. For a more complete inventory of the intervallic resources of a Pythagorean diatonic scale, see Chart 2A.

The Pythagorean tuning method is not limited to seven tones per octave. Indeed, it can generate an infinite series of starting tones, without ever reaching any octave of the starting point. When this process is carried through 12 successive  $3/2$ 's, a tone is reached which differs from  $27/1$  above the starting point by the interval  $531441/524288$ , known as the Pythagorean comma (see Chart 3A). Thus, true 5ths do not form a closed circle, but an infinite one-dimensional series.

In order to obtain a scale with consonant 3rds and 6ths, in

addition to 4ths and 5ths, it is necessary to add another prime factor, 5. Five limit scales do not consist of single chains of one interval, as Pythagorean scales do, but rather form 2-Dimensional grids, with chains of  $3/2$ 's intersecting chains of  $5/4$ 's (just major thirds -- see Chart 3B). The best known scale of this type is Ptolemy's Syntonon Diatonic, generally regarded as the best just model of the Western Major scale. If we compare the intervallic resources of this scale to those of the Pythagorean Diatonic (Chart 2B), the most important difference is that most 3rds and 6ths are represented by much simpler ratios in the Syntonon Diatonic. It should also be noted that the Syntonon has one perfect 5th and 4th fewer than the Pythagorean. Five limit scales contain the major and minor Triads

characteristic of traditional Western harmony. Indeed, the Syntonon Diatonic can be regarded as consisting of three major triads constructed on the "tonic", "dominant", and the "subdominant" degrees of the scales.

In examining the 5-limit grid (Chart 3B), it will be noted that many pairs of points labelled with different ratios share the same "name". I.e.: If starting at C =  $1/1$ , we ascend (move horizontally to the right) four perfect 5ths, we reach a note called "E" with a ratio of  $81/64$ . If, instead, we ascend (move up a vertical) from  $1/1$  by one major 3rd, we reach a note labelled "E" with a ratio of  $5/4$ . From their ratios, it is obvious that these are two different pitches. Specifically,  $81/64$  is higher than  $5/4$  by the small interval  $81/80$  (21.5 cents), known as the comma of Didymus.

CHART 1A

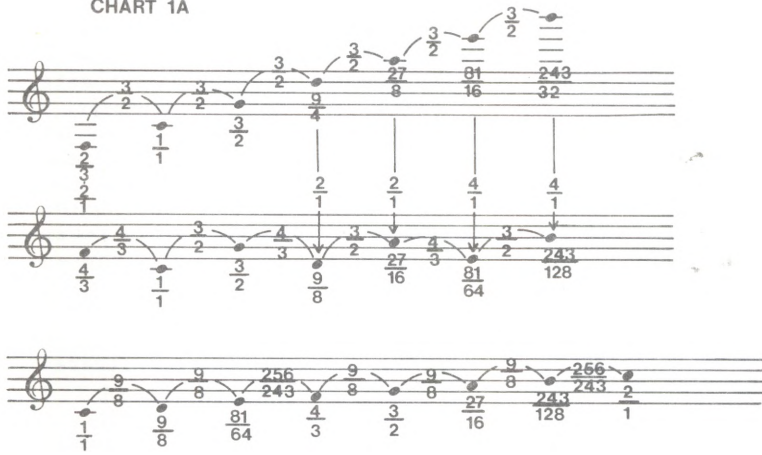
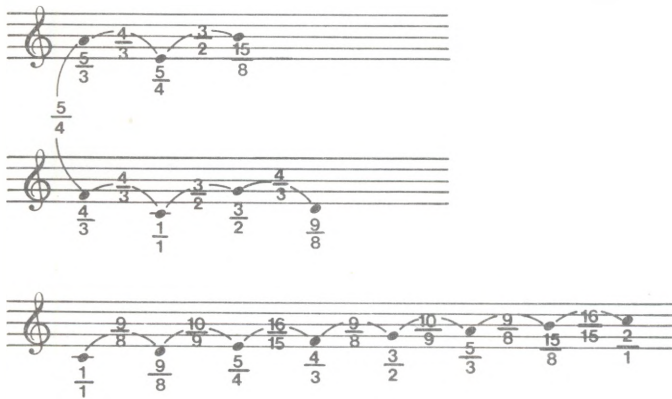

CHART 1B



		9/8	81/64	4/3	3/2	27/16	243/128	1'/1
1/1	9/8	81/64	4/3	3/2	27/16	243/128	2/1	9'/8
9/8	9/8	32/27	4/3	3/2	27/16	16/9	2/1	81'/64
81/64	256/243	32/27	4/3	3/2	128/81	243/128	2/1	4'/3
4/3	9/8	81/64	729/512	3/2	27/16	16/9	2/1	3'/2
3/2	9/8	81/64	4/3	3/2	27/16	16/9	2/1	27'/16
27/16	9/8	32/27	4/3	3/2	128/81	16/9	2/1	243'/128
243/128	256/243	32/27	4/3	1024/729	128/81	243/128	2/1	1

2nds 3rds 4ths 5ths 6ths 7ths 8ths

CHART 2A

		9/8	5/4	4/3	3/2	5/3	15/8	1'/1
1/1	9/8	5/4	4/3	3/2	5/3	15/8	2/1	9'/8
9/8	10/9	32/27	4/3	40/27	5/3	16/9	2/1	5'/4
5/4	16/15	6/5	4/3	3/2	8/5	9/5	2/1	4'/3
4/3	9/8	5/4	45/32	3/2	27/16	15/8	2/1	3'/2
3/2	10/9	5/4	4/3	3/2	5/3	16/9	2/1	5'/3
5/3	9/8	6/5	27/20	3/2	8/5	9/5	2/1	15'/8
15/8	16/15	6/5	4/3	64/45	8/5	16/9	2/1	1

2nds 3rds 4ths 5ths 6ths 7ths 8ths

CHART 2B

CHART 2C

		9/8	7/6	5/4	21/16	4/3	3/2	5/3	7/4	15/8	1/1
1/1	9/8	7/6	5/4	21/16	4/3	3/2	5/3	7/4	15/8	2/1	9/8
9/8	28/27	10/9	7/6	32/27	4/3	40/27	14/9	5/3	16/9	2/1	7/6
7/6	15/14	9/8	8/7	9/7	10/7	3/2	45/28	12/7	27/14	2/1	5/4
5/4	21/20	16/15	6/5	4/3	7/5	3/2	8/5	9/5	28/15	2/1	21/16
21/16	64/63	8/7	80/63	4/3	10/7	32/21	12/7	16/9	40/21	2/1	4/3
4/3	9/8	5/4	21/16	45/32	3/2	27/16	7/4	15/8	63/32	2/1	3/2
3/2	10/9	7/6	5/4	4/3	3/2	14/9	5/3	7/4	16/9	2/1	5/3
5/3	21/20	9/8	6/5	27/20	7/5	3/2	63/40	8/5	9/5	2/1	7/4
7/4	15/14	8/7	9/7	4/3	10/7	3/2	32/21	12/7	40/21	2/1	15/8
15/8	16/15	6/5	56/45	4/3	7/5	64/45	8/5	16/9	28/15	2/1	

This small interval is critical. E' = 5/4 is the proper pitch for the 3rd of a major triad on C = 1/1; E = 81/64 is the proper pitch for the 5th of a major triad on A = 27/16. The substitution of the incorrect "E" in either of these cases will change a simple consonance into a grating dissonance.

These matters are of great importance in understanding the problems of modulation and transposition. It has frequently been claimed that modulation is impossible in just intonation. In fact, modulation may be achieved in a number of ways in just intonation, depending on how you choose to define the term. At its simplest, modulation merely means a

change in perceived tonal center. This can be achieved in a variety of ways, with or without alterations to the tonal set. The classical European definition of modulation includes the notions of transposition to a parallel scale. This is also possible in just intonation, with the restriction that your tuning system must have all of the tones of any scale to which you might wish to modulate. Refer to Chart 3B; the heavy lines represent the syntonon diatonic in the key of C = 1/1. Modulation to a parallel key may be represented by moving this figure in relation to the grid (without rotation) so that another tone occupies the position currently held by 1/1.

If we move the figure in such a way as to modulate to G = 3/2, the "Dominant", we find that two tones, A = 5/3 and F = 4/3, are lost, and two new tones, A' = 27/16 and F# = 45/32, are added. While the substitution of F# for F is analogous to procedure in equal temperament, the substitution of A' = 27/16 for A = 5/3 (these two tones differ by the above-mentioned comma of Didymus) is a subtlety peculiar to just intonation. Examine other common modulations on the chart, and you will observe that the scope of possible modulation in any just system is limited by the availability of the required tones.

Thus far, the scales examined have harmonic and melodic properties somewhat analogous to those of equal temperament, the major differences being that just systems possess a greater degree of consonance and a greater potential for harmonic and melodic subtlety, while equal temperament offers relative ease of modulation. With the addition of higher prime numbers, just systems can be created which involve intervals that have no equivalents in Western music.

The properties of 7, the next prime, have been fairly well explored. Certain non-European musics, including the Blues, seems to use intervals involving seven extensively, and even European classical harmony seems to "imply" the existence of seven, albeit with much ambiguity.

The primary interval generated by 7 is 7/4, known as the "Harmonic 7th". This interval adds a new dimension to the 5 limit grid, transforming it into a

CHART 3A

G <sup>b</sup>	D <sup>b</sup>	A <sup>b</sup>	E <sup>b</sup>	B <sup>b</sup>	F	C	G	D	A	E	B	F <sup>#</sup>
1024/729	256/243	128/81	32/27	16/9	4/3	1/1	3/2	9/8	27/16	81/64	243/127	729/512

C'	G'	D'	A'	E'	B'	F#'	C#'	G#'
160/81	40/27	10/9	5/3	5/4	15/8	45/32	135/128	405/256
A <sup>b</sup>	E <sup>b</sup>	B <sup>b</sup>	F	C	G	D	A	E
128/81	32/27	16/9	4/3	1/1	3/2	9/8	27/16	81/64
F <sub>1</sub>	C <sub>1</sub>	G <sub>1</sub>	D <sub>1</sub>	A <sub>1</sub>	E <sub>1</sub>	B <sub>1</sub>	F <sub>1</sub>	C <sub>1</sub>
512/405	256/135	64/45	16/15	8/5	6/5	9/5	27/20	81/80

CHART 3B



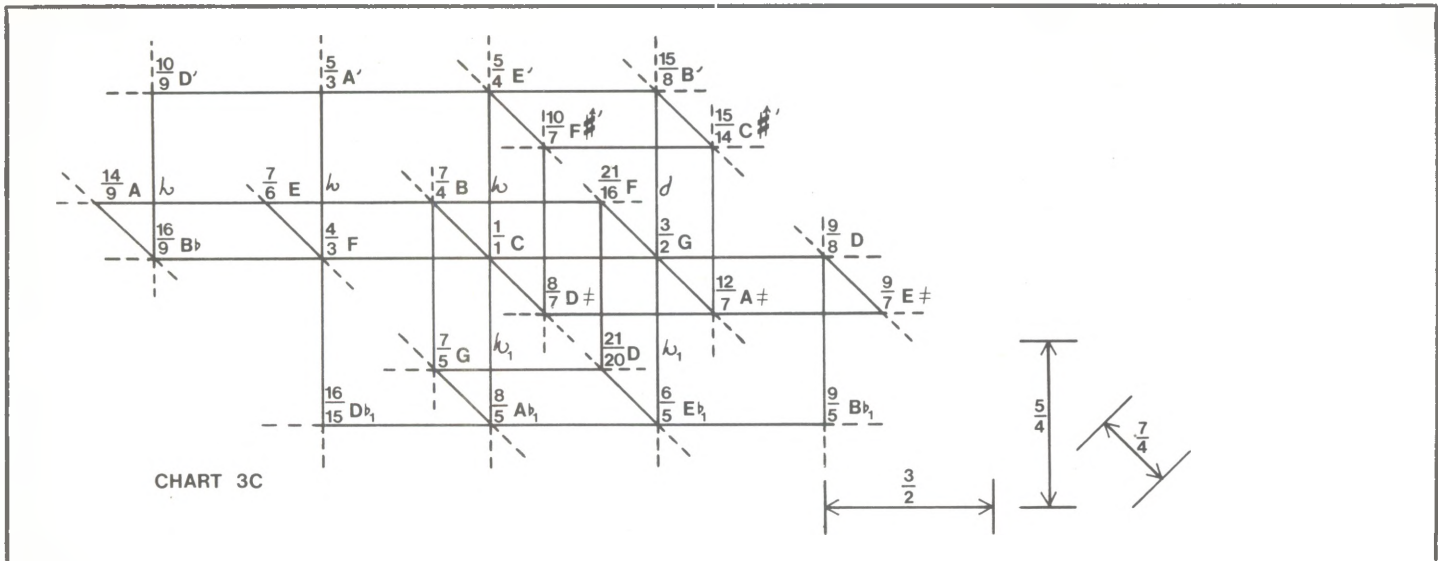

CHART 3C

3-dimensional lattice (Chart 3C). While the increased complexity of this system is apparent to the eye, the benefits to be realized here are best discovered by the ear.

The most important resources of this expanded tonal universe is a new class of relative consonances, involving 7 as a factor. The substitution of intervals from the 7 limit, for those involving more complex ratios involving lower primes, can transform chords traditionally considered dissonant and in need of resolution into stable consonances. The most striking instances are the use of 7/4 as the 7th of the dominant 7th chord, and 7/5 as the diminished 5th of the diminished triad. Other new relative consonances include 7/6 and 12/7 (the "Subminor 3rd" and "Supermajor 6th"), 10/7 (another "Septimal Tritone"), and 9/7 and 14/9 (the "Supermajor 3rd" and the "Subminor 6th"). Referring to Chart 3C, it will be seen

that there are at least three possible values for the interval conventionally known as a minor 7th: 7/4 (968.7 cents), 16/9 (996 cents), and 14/9 (1017.5 cents). The difference between the greatest and smallest of these is the interval 36/35 (48.8 cents), nearly a "quartertone".

The septimal consonances listed above share a common expressive quality, peculiar to intervals involving 7, which, for lack of a better term, might be called "Blueness". Chart 2C shows the intervallic resources of a ten tone blues scale generated by adding harmonic 7th to the tonic, subdominant and dominant degrees of the syntonon diatonic. With regard to modulation, within the 7 limit, the same considerations apply as were discussed above, except that there we are concerned with the movement of a three-dimensional field.

It seems likely that all of the remaining primes below 20 (11,

13, 17, 19) can be of some musical value, but this territory remains largely unexplored. Indeed, the use and re-discovery of just intonation is only beginning. Of course, commitment to a new tuning system entails a substantial effort. At the very least, it involves learning new theories and compositional techniques. In addition it may require the development of new playing techniques for instruments which are intonationally flexible (voice, fretless strings, trombones), modification and/or retuning of those which are not (refretting guitars, retuning keyboards, creating new types of pitch controllers for synthesizers), or designing and building entirely new instruments. Any of these approaches demands a major investment of time and energy. For those willing to make it, the reward is nothing less than a new and unexplored tonal universe.

## Basic Intonational Math

In just intonation, musical intervals are expressed as ratios of whole numbers. In order to understand, and, more importantly, to create just scales, it is necessary to be able to add, subtract, and compare these ratios.

This can be easily done, with the aid of a few simple rules. First, it should be noted that ratios served two distinct but related functions. First, a ratio represents a particular interval, regardless of what specific pair of tones it separates. Second, the same ratio can represent one particular tone which is related to 1/1 by that particular interval. Thus, 3/2 represents any perfect fifth,

but 3/2 also represents the tone a perfect fifth above 1/1 (remember, when ratios are used to represent tones they are underlined).

Frequency ratios should always be expressed in least terms, and the numerator should always be used to represent the higher frequency.

To add two ratios, multiply straight across:

$$3/2 + 9/8 = (3*9)/(2*8) = 27/16; \quad 3/2 + 4/3 = (3*4)/(2*3) = 12/6 = 2/1$$

# Ratios for Just Scales

By:  
Craig  
Anderton

Reading this article got me interested in the idea of coming up with a just intonation circuit board that would generate a just intoned scale from a master clock. Unfortunately, time limitations have prevented me from pursuing this, but I did get as far as doing some calculations...which are presented here.

The basic idea behind the just intoned equivalent of a top octave divider is to have a master clock which is many times higher than the desired frequency, with dividers to provide just intoned intervals. Modulation can occur by varying the clock frequency. The dividers can use 4017s or equivalent counters to create the proper divisors. For example, if you need a divide-by-144 circuit, simply cascade two divide-by-12 circuits in series.

For a simple pentatonic scale, start with a master clock 60 times higher than the desired lowest note of the octave. Here's how you would divide this down to create the scale:

Note	Divide Master Clock By
C (low)	60 (ratio of 1/1)
E	48 (ratio of 5/4)
F	45 (ratio of 4/3)
G	40 (ratio of 3/2)
A	36 (ratio of 5/3)
C (high)	30 (ratio of 2/1)

For a simple seven tone scale, start with a master clock 180 times higher than the desired lowest note of the octave. Here is the pertinent information:

Note	Divide Master Clock By
C (low)	180 (ratio of 1/1)
D	160 (ratio of 9/8)
E	144 (ratio of 5/4)
F	135 (ratio of 4/3)
G	120 (ratio of 3/2)
A	108 (ratio of 5/3)
B	96 (ratio of 15/8)
C (high)	90 (ratio of 2/1)

Now all I have to do is sit down and breadboard a bunch of dividers! When I get it done, I'll write it up; in the meantime, the above information should be enough to get most of you started.

Incidentally, I have heard electronically-generated just intoned scales, and the sound is very different from conventional even-tempered scales. In fact, a standard top octave divider sounds quite out of tune if you listen to it right after listening to a just intoned divider. The subject is definitely worth pursuing; as David says, "the reward is nothing less than a new and unexplored tonal universe."

To subtract one ratio from another, invert the ratio to be subtracted, then multiply:

$$\frac{3}{2} - \frac{9}{8} = \frac{(3*8)}{(2*9)} = \frac{24}{18} = \frac{4}{3}; \quad \frac{3}{2} - \frac{4}{3} = \frac{(3*3)}{(2*4)} = \frac{9}{8}.$$

When a ratio is used to label a particular tone, the same ratio is used, regardless of what octave the tone falls in. Suppose, for instance, we wish to know what tone is a 7/4 higher than 3/2. We add the two ratios and obtain the answer  $\frac{21}{8}$ . Since 21 is greater than 2\*8, we know that  $\frac{21}{8}$  is greater than 2/1 (an octave). It is the convention to represent tones with the ratios they have in the octave bounded by 1/1 and 2/1. In order to do this, we subtract 2/1 from  $\frac{21}{8}$  and obtain the correct result,  $\frac{21}{16}$ . If, as a result of subtraction, we obtain a ratio in which the denominator is greater than the numerator, this means that the tone to which it refers is below 1/1 and must be "raised" by one octave in order to be expressed in proper form:

$$\frac{9}{8} - \frac{3}{2} = \frac{(9*2)}{(8*3)} = \frac{18}{24} = \frac{3}{4};$$

$$\frac{3}{4} + \frac{2}{1} = \frac{(3*2)}{4} = \frac{3}{2}$$

## MOVING?

When writing to change the address on your POLYPHONY subscription it is important that you enclose the mailing label. Our computer cannot locate your name on the subscription list without it.

ATTACH OLD LABEL HERE

### NEW ADDRESS

Name \_\_\_\_\_  
Address \_\_\_\_\_  
City \_\_\_\_\_ State \_\_\_\_\_ Zip \_\_\_\_\_

mail to: **Polyphony**  
PO BOX 20305  
Oklahoma City, OK 73156

READ THE LATEST  
NEWS, REVIEWS  
IN **Polyphony**

**NEXT ISSUE:**  
**Orchestral Voicing**  
**Film Scoring Math**

To compare the magnitude of intervals, their ratios must be converted to "cyclic cents", the unit of measure invented by the 19th century British physicist Alexander V. Ellis. One cent is equal to 1/1200 of an octave, or 1/100 of an equally tempered semitone. To find the number of cents in an interval, first convert the ratio to a decimal, then find its base 10 logarithm and multiply that by 1200/Log2 (approximately 3986). For example:

$$\frac{3}{2} = 1.5$$

$$\text{Log } 1.5 = 0.17609$$

$$0.17609 * 3986 = 701.9 \text{ cents (the equal tempered 5th is 700 cents).}$$

Once converted to cents, interval values are subject to the usual operations of arithmetic. To obtain the cents value of an interval in 12 tone equal temperament, multiply the number of semitones in the interval by 100.



# Fender's Triad Interface



The Chroma Keyboards division of Fender musical instruments has introduced a new instrument interface bus, called Triad™. This system lets users connect instruments to computers via a 25-pin D-connector cable; multi-instrument connections can be made by using one Triad device (for example, a Triad-equipped computer) as a star-network controller.

Triad-equipped instruments will have two uni-directional 8-bit parallel ports (one output, one input) and two handshaking lines for each port. This structure is intended to provide extra flexibility in the way that a Triad system responds to data. The handshaking lines can be polled or used to interrupt the Triad device.

The software characteristics of the Triad interface make it unique among instrument interfaces. Multi-byte operating commands are transferred across the bus, and the receiver interprets and acts upon those commands. All Triad-equipped devices that produce musical sounds are organized as logical instruments. The number of logical instruments available in the device can be communicated through the Triad interface.

The instrument consists of "channels" assigned to it and a data structure defining the sound of that instrument. The channels are the actual sound generation modules in the Triad device. The total number of channels available can change (due to adding expanders, etc.) and be communicated through the interface. The number of channels allocated to a particular instrument can be controlled through the Triad interface or automatically set by the Triad device when the instrument is defined.

All Triad-equipped devices are capable of receiving data to be acted upon at a future time. This is accomplished by using relative time commands.

Each command can be preceded by a time command that tells a Triad device when to execute the command (relative to the last execution in that logical instrument). The time command values are in increments of 1/192 notes. Time synchronization between Triad devices is accomplished by beat commands that are sent over the interface by either device. The beat commands are sent only when the time base should be changed.

All Triad devices are capable of time stamping the commands representing performance and panel events. That is, the device can simulate a recorder or sequencer. The commands which control these functions are standardized and accessible from the Triad interface.

The Triad command structure permits device-dependent data to be transferred over the interface. A program that defines a sound, for example, can contain information useful to that particular device. The structure of other device-dependent command functions (such as the SET PARAMETER function on a Chroma Polaris synthesizer) is standardized. But what the device actually does with this data is device-dependent. For example, ET PARAMETER 3 TO 0 could mean "set the keyboard algorithm to polyphonic" in a Chroma-type synthesizer; or "set the modulation index to 0" in a digital synthesizer. Also, an escape command sequence is available for use with device-dependent functions to be developed in the future.

The Triad interface also provides other functions including "peeking" and "poking", or otherwise interrogating or changing the device's internal workings. Any cassette interface that the device controls can be accessed over the Triad interface. And commands relating to interface data flow control are also available.

**WIND PLAYERS  
VOCALISTS**

You can use your own instrument or voice to control any standard synthesizer, with more expressiveness than a keyboard.



**THE GENTLE ELECTRIC  
PITCH AND ENVELOPE  
FOLLOWER**

Write for our free detailed brochure, patch diagrams, and application notes.

Also available as modules for Aries and Serge synthesizers, or as circuit boards for custom systems. Dealers inquiries welcome.

*gentle electric*

Dept. P  
P.O. Box 132, Delta, CO 81416  
(303) 874-7171

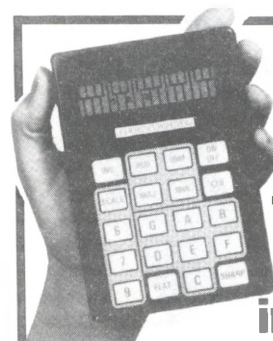

**Music  
Teacher  
in a Box?**

To get ahead in music, you need to know music theory. PAIA's Chord Computer helps you understand both music and keyboards better by cramming the equivalent of pages and pages of music theory into a compact, calculator-style package.

The Chord Computer is easy to use. Simply select a chord letter, and the Chord Computer's LCD 31-key piano keyboard display will show which notes to play for the selected chord. Press another button to choose sharp, flat, major, minor, augmented, diminished, 6th, 7th or 9th chords — including inversions. The Chord Computer can also display complete scales for all keys, or even transpose them at the touch of a button.

Serious about music? The Chord Computer could be the best investment you'll ever make. **only \$59.95** (plus \$2.50 postage/handling) **Order yours today...**

**CHARGE TO VISA OR MC TOLL-FREE**  
1-800-654-8657 9AM to 5PM CST MON-FRI

Ask for your free PAIA catalog.  
Direct mail orders and inquiries to: Dept. 8Y

**PAIA Electronics, Inc.**

1020 W. Wilshire, Oklahoma City, OK 73116 • (405) 843-9626

# re-view

continued from page 35

The The Perfect (Epic A13-3119)(12" single). Like his previous releases (April '83, June '83), Matt Johnson plays all the instruments himself (well, except harmonica, for some reason) and comes up with two more pieces which are attractive without being condescending. Slightly cynical perhaps, but not condescending.

The Happiness Boys **Meat Parade** (Duo-1)(EP). Instrumental Dada rock based on, and largely consisting of, an Oberheim DMX digital drum unit. The rhythms, which themselves are pretty good, are fleshed out with minimalist guitar, a little saxophone, ring modulation, tapes, and lots of electronic noises. It isn't pretty, but then meat parades never are.\*

Intence **A Fond Perdu** (SSU 813); **Out of Blue Fashion** (SSU 829). Intence consists of Helmut Brunner

and Clemens Glaser on keyboards and sequencers, and Clemens' brother Rudiger on drums and electronic percussion. Their music begins with the rhythmic regularity of analog sequencers, adds just a little drumming, and builds layers of short phrases on keyboard synthesizers. Frequent voice, key, and phrase changes keep it from sounding too repetitive, although the beat doesn't change and the synthesizers are pretty dry. Contact Intence Music, Postfach, 7553 Muggensturm, West Germany.

Michael Garrison **Eclipse** (Windspell 112882). On his third album, Garrison has his style down to a "T" -- very fluid sequenced bass and percussion, with a string synthesizer arpeggiating chords over it. It's a very mild, almost elevator music with no surprises -- except the four numbers featuring a female vocalist. But she sings in unison with the lead instrument (the way most instrumentalists write vocal music) so she doesn't really change the music that much.

Tom Cameron **Music to Wash Dishes By** (Bathing 1003). Despite the title, if you tried to wash dishes to this stuff it would probably take you all night to clear the sink. No, this is music to stare into a light bulb with. Most of it is slow, echo-laden meditations using EML synthesizers, although the title track builds to a frenetic conclusion and the short number after it sounds like a cartoon soundtrack.\*

\*Albums marked with an asterisk are available from New Music Distribution Service.

NEW MUSIC DISTRIBUTION SERVICE is a division of the Jazz Composers Orchestra Association Inc. a not for profit organization. The organization can be contacted at: NMDS, 500 Broadway, New York, NY 10012, Telephone 212-925-2121.

## Guitar Tuner

**\$39.95**



**Accurate  
Easy to use**

**Unbelievably inexpensive**

...that's our new BANANA quartz guitar tuner. Thru-jacks let you tune electric guitars without unplugging. Acoustic guitars tune with built in condenser mic. Internal speaker produces by-ear tones if you want them.

Two easy to use tuning indicators -- a meter to indicate pitch deviations up to 1/2 semi-tone and LED go-no-go indicators, both with quartz accuracy.

Runs for months on a single AA penlight and one 9v. battery.

No. 9700A ..... only **\$39.95**  
plus \$2.00 shipping.

Order yours today . . . .

**CHARGE TO VISA OR MC TOLL-FREE**  
1-800-654-8657 9AM to 5PM CST MON-FRI

Ask for your free PAIA catalog.

Direct mail orders and inquiries to: Dept. 8Y

**PAIA Electronics, Inc.**

1020 W. Wilshire, Oklahoma City, OK 73116 (405)843 9626

## AD INDEX

Dickstein Dist. co.	19
Electro-Harmonix	13, 37
E-Mu Systems, Inc.	48
Gentle Electric	43
Musitech	46
Oberheim Electronics	2
PGS Electronics	45
PAIA Electronics	17, 35, 42, 43, 44, 47
Phoenix Systems	8
Polymart	28, 29, 30
Telex	7

### PLUG INTO

## Polyphony

### FOR ELECTRIFYING IDEAS!

- ( ) One year \$12 US/\$14 foreign  
(6 issues)
- ( ) Two years \$22 US/\$24 foreign

VISA/ Mastercharge accepted.  
Card No. \_\_\_\_\_  
Expiration date: \_\_\_\_\_

\_\_\_\_\_  
(signature)

Name: \_\_\_\_\_

Mail to:

Address: \_\_\_\_\_

POLYPHONY, P. O. Box 20305

City: \_\_\_\_\_ state: \_\_\_\_\_ zip: \_\_\_\_\_

Oklahoma city, OK 73116

**DON'T MISS AN ISSUE SUBSCRIBE TODAY!**



## LINEARS

TL061.....BiFet.....	.72
TL062.....Dual BiFet.....	.99
TL064.....Quad BiFet.....	1.95
TL071.....BiFet.....	.65
TL072.....Dual BiFet.....	1.15
TL074.....Quad BiFet.....	1.95
NE555.....Timer.....	.39
NE570.....Compander.....	3.80
NE571.....Compander.....	2.95
NE572.....Compander.....	4.95
UA741.....Comp. OpAmp.....	.29
MC1456.....Low Noise OpAmp.....	.90
RC1556.....Low Noise OpAmp.....	1.48
CA3080.....OTA.....	.94
CA3280.....Dual OTA.....	1.98
RC4136.....Quad OpAmp.....	1.10
RC4739.....Dual Low Noise.....	1.19
NE5532.....Dual High Perf.....	3.70
NE5534.....High Performance.....	2.65

## SPECIAL PURPOSE

SAD-1024.....Analog Delay.....	17.50
SAD-4096.....Analog Delay.....	37.50
MK50240.....Top Octave Div.....	5.95
SN76477.....Sound Generator.....	3.45

## SANYO HYBRID POWER AMPS

STK050.....50 Watt Power Amp.....	19.40
STK070.....70 Watt Power Amp.....	24.20

## SSM- SOLID STATE MICRO-TECHNOLOGY

SSM 2010.....VCA.....	7.50
SSM 2011.....PreAmp.....	5.75
SSM 2012.....VCA.....	9.50
SSM 2020.....VCA.....	7.50
SSM 2022.....VCA.....	7.50
SSM 2030.....VCO.....	7.50
SSM 2033.....VCO.....	10.00
SSM 2040.....VCF.....	7.50
SSM 2044.....VCF.....	7.50
SSM 2050.....VCTG.....	7.50
SSM 2056.....VCTG.....	5.75

## THERMISTER (Temp. Sensing Resistor)

TSR-Q81.....Tel Labs Q81 1k.....	\$3.50
----------------------------------	--------

## OPTO-ISOLATOR

CLM6000.....Clairex CLM6000.....	\$2.85
----------------------------------	--------

## CAPACITORS (25 volt)

701-100.....100 pf polystyrene.....	.25
701-180.....180 pf polystyrene.....	.25
701-1000.....1000 pf polystyrene.....	.25
701-2200.....2200 pf polystyrene.....	.25
701-2200.....3300 pf polystyrene.....	.25
701-3900.....3900 pf polystyrene.....	.25
702-005......005 uf mylar.....	.12
702-01......01 uf mylar.....	.12
702-05......05 uf mylar.....	.16
702-1......1 uf mylar.....	.21
702-22......22 uf mylar.....	.33
703-1.0.....1.0 uf tantalum.....	.39
703-3.3.....3.3 uf tantalum.....	.49
703-4.7.....4.7 uf tantalum.....	.59
704-2.2.....2.2 uf electrolytic.....	.21
704-4.7.....4.7 uf electrolytic.....	.21
704-10.....10 uf electrolytic.....	.21
704-100.....100 uf electrolytic.....	.31
705-10.....10 pf ceramic disk.....	.15
705-.01......01 uf ceramic disk.....	.12
705-.1......1 uf ceramic disk.....	.17

## IC SOCKETS (solder tail)

IC-S-08.....8 pin high quality socket.....	.27
IC-S-14.....14 pin high quality socket.....	.30
IC-S-16.....16 pin high quality socket.....	.34
IC-S-18.....18 pin high quality socket.....	.40
IC-S-28.....28 pin high quality socket.....	.60
IC-C-08.....8 pin economy socket.....	.13
IC-C-14.....14 pin economy socket.....	.15
IC-C-16.....16 pin economy socket.....	.17
IC-C-18.....18 pin economy socket.....	.20
IC-C-28.....28 pin economy socket.....	.40

## RESISTORS 5%, 1/4 watt

All EIA values available from 2.0 ohm to 5.1 Meg.  
Also available is 10 Meg.

100 each of same value.....	\$1.50
50 each of same value.....	.98
25 each of same value.....	.75
10 each of same value.....	.40
5 each of same value.....	.25

## ASSORTMENTS

10 each of 10 values (100).....	3.00
25 each of 10 values (250).....	6.50
50 each of 20 values (1000).....	16.00

## CHORUS/DELAY KIT

This chorus/delay unit, designed by Craig Anderton and featured in Guitar Player magazine, provides flanging, slapback echo, and automatic double tracking effects. The delay range is from 2 ms to 80 ms. Due to the use of compression and expansion techniques, the unit has dead-quiet operation up to about 50 ms and only minimal noise out the full 80 ms. This project kit consists of all electronics, pots, jacks, etc. Also included are the two circuit boards (etched, drilled, and legended) needed for the project. Not included is wire, solder, case, knobs, etc. The Chorus/Delay unit also needs a well regulated bi-polar 15 volt power supply (not included). (A punched and legended rack mount panel will soon be available for this project.)

Order KT-CD777..... \$78.00

## "SNARE +" DRUM VOICE KIT

This percussion synthesizer was designed by Thomas Henry and appeared in POLYPHONY magazine. Here's what Craig Anderton had to say about the "SNARE +": "At last - an inexpensive drum voice that has a punchy, full sound. ....All in all, the Snare + delivers a lot of drum sounds, and I would unhesitatingly recommend it to anybody who's tired of the thin sound found in most electronic drum units."

We offer the kit with or without a panel. Kit 3770 contains all electronic parts, switches, jacks, pots, etc, as well as etched, drilled, and legended circuit board. Kit 3772 includes all this plus a punched and legended rack mount panel (standard 1 3/4 by 19 inches) available in black or blue (both with white legends).

Not included with either kit is wire, solder, mounting hardware, etc. The SNARE + also needs a bi-polar 15 volt power supply (not supplied).

Kit 3770 Basic SNARE + kit..... \$33.95  
Kit 3772 SNARE + with rack panel... \$44.94

## THE "CLARIFIER" GUITAR EQ/PREAMP

The "CLARIFIER" is an onboard preamp/EQ module for guitar. This design, by Craig Anderton, was first seen in the pages of GUITAR PLAYER magazine. Here's what the CLARIFIER will do: Replace the guitar's standard passive tone control with a two control, active circuit which provides over 12 db of bass and treble boost and up to 6 db cut... Buffer your pickups from external loading, giving additional output and improve high freq response... Add a nominal 6 db of gain to give your signal a bit more punch, as well as improve the signal/noise ratio in multiple effects systems... make your guitar immune to the high freq loss caused by long cable runs.

The CLARIFIER kit is available in two options, both of which include a high quality drilled, legended, and masked circuit board, as well as complete step by step instructions. Kit 2450 contains everything needed for a complete unit... Kit 2455 contains everything except the pots (for those who prefer a particular brand of potentiometer). Batteries are not included with either kit.

Kit 2450.....Complete CLARIFIER kit .. \$18.95  
Kit 2455.....CLARIFIER less controls ..\$14.95

**TERMS: (Check, Money Order, Cashiers Check - Add .75 if under \$10.00) - (\$10.00 minimum on C.O.D. (UPS only) add \$1.50) - (Mastercard and Visa: \$10.00 minimum. You must supply exp. date.) - (Indiana residents add sales tax.)**

**SHIPPING AND HANDLING: \$1.00 plus 5% of purchase. We will credit any amount over our standard rate.**

**SATISFACTION GUARANTEED!**

## SIGNAL DIODE

601-60.....1N914 (1N4148) signal diode .. 5/35

## TRANSISTORS

2N3904.....2N3904 NPN Transistor.....	.25
2N3906.....2N2906 PNP Transistor.....	.25

## POTENTIOMETERS

(3/8 long shaft, 5/16 mounting hole)

854-401.....10K Linear taper.....	1.09
854-501.....100K Linear taper.....	1.09
854-505.....500K Linear taper.....	1.09
855-401.....10K Audio taper.....	1.09
855-501.....100K Audio taper.....	1.09
855-505.....500K Audio taper.....	1.09
856-401.....10K Audio taper with on/off switch.....	1.25

## TRIM POTS (vertical mount)

802-251.....250 ohm trimmer.....	.40
802-103.....10K trimmer.....	.40

## MINI TOGGLE SWITCHES

403-20.....SPDT (on/on) sub-mini (3A)....	1.20
403-40.....DPDT (on/on) sub-mini (3A)....	1.50
405-10.....SPST (on/off) bat handle (6A). 1.85	

## LED's

Please note that the typical DC forward current (I-fwd) of these LED's is less than those offered elsewhere making these LED's ideal for battery circuits or others where current consumption is a factor.

305-201.....Red T-1 1/4 jumbo diffused (20 ma)....	.30
305-202.....Green T-1 1/4 jumbo diffused (30 ma)....	.40
305-203.....Dual T-1 1/4 jumbo diffused (50 ma)....	.90
305-204.....Tri T-1 1/4 jumbo diffused (20 ma)....	1.50

Note: 305-204 is a three lead, tri-color (green, red, yellow) device. It is essentially two separate LED's in one package. (The yellow is obtained by turning on both green and yellow.)

## JACKS and PLUGS

### 1/4 In. PHONE JACKS

901-101.....Mono standard phone jack.....	.45
901-103.....Mono with n/closed contact.....	.52
901-105.....Mono encl. jack (open back).....	.55
902-211.....Stereo standard phone jack.....	.70
902-213.....Stereo encl. jack (open back)....	.77

### 1/8 In. MINI JACKS

903-351.....Mono with n/closed contact.....	.32
903-353.....Mono encl. (open back).....	.26
903-355.....Mono enclosed with contact.....	.35

### RCA JACKS

921-100.....RCA jack, chassis mount.....	.34
921-200.....RCA jack on phenolic mount....	.25
921-300.....Dual RCA on phenolic mount....	.43

### 1/4 In. PHONE PLUGS

911-201.....Mono, black phone plug.....	.48
911-203.....Mono, red phone plug.....	.48
911-205.....Mono, chrome (metal) plug.....	1.20
911-211.....Stereo, black phone plug.....	.65

### 1/8 In. MINI PLUGS

913-251.....Mono, black mini plug.....	.38
913-253.....Mono, red mini plug.....	.38
913-255.....Mono, chrome (metal) plug.....	.56

## SWITCHING JACKS

These are stereo phone jacks that contain an independent switching system that is controlled by the insertion of the plug. Jack 905-301 contains the equivalent of a DPST normally on switch. Jack 905-302 contains the equivalent of a DPDT on/on switch making it ideal for switching bi-polar power supplies on and off in effects boxes, etc.

905-301.....Stereo jack with SPST switch... ..	.90
905-302.....Stereo jack with DPDT sw. ....	1.00

**PGS ELECTRONICS**  
**Route 25 - Box 304**  
**Terre Haute, IN 47802**

# EQUIPMENT EXCHANGE

PUT POLYPHONY TO WORK FOR YOU. List equipment for sale or trade, job openings, positions wanted, etc. Equipment exchange classified rates for individuals offering goods or services for sale or trade: 25c per word, 20 word (\$5.00) minimum charge; Commercial establishments: 50c per word. Prices, zip, phone numbers count as one word each. DISPLAY CLASSIFIED: \$15 per column inch, one inch minimum, camera ready art to be supplied by advertiser. All classified advertising must be prepaid. Advertisers using a Post Office Box number for responses must furnish Polyphony Publishing Co. with a complete street address and phone number. Readers should respond directly to advertiser. Polyphony is not responsible for claims made in ads, or for the results of any transactions. Polyphony reserves the right to edit or refuse any ads submitted.

## SALE

### OVERSTOCK ITEMS

CASIO 202 Keyboard: \$445 ppd.  
Electro-Harmonix MINI-SYNTH w/ECHO: Touch-sensitive keyboard & ribbon controller - once you pick it up it's hard to put it down! \$249 ppd.  
Moog TAURUS II CONTROLLER: Control your synth with Bass Pedals, \$400 ppd.  
Moog ROGUE Synthesizer: \$322 ppd.  
ROGUE HARDSHELL CASE: \$40 ppd.  
ANVIL ATA MEMORYMOOG CASE: \$255 ppd.  
ANVIL ATA BRIEFCASE: \$40 ppd.

### DIGITAL

Moog SL-8 SYNTHESIZER: Call for price.  
360 SYSTEMS DIGITAL KEYBOARD: \$3995 ppd.  
Free Anvil ATA Case w/purchase. Free instrument voice w/purchase of Page 2 Memory Expansion.\*  
SOUNDCHASER II: Complete system including Turbo Traks, Demo disk, \$1350 ppd. Plus one additional Software Program free.\*  
\*Free offers expire Sept. 30, '83.  
MOUNTAIN COMPUTER MUSIC SYSTEM: Complete, for all Apple-compatible computers, \$349 ppd.  
ELECTRO-HARMONIX 16 SEC DIGITAL DELAY: \$395 ppd.  
ELECTRO-HARMONIX 64 SEC DIGITAL DELAY: Rack-mount, call for price.  
ELECTRO-HARMONIX "INSTANT REPLAY": 2 second digital recorder w/looping, triggered by percussion controller (included), or transposed by synthesizer control - the "Poor Man's Fairlight", \$195 ppd.

### VINTAGE MOOG

MINIMOOG, MULTIMOOG, POLYMOOG, PRODIGY: New & reconditioned units in stock.

### SERVICE

All items carry a full factory warranty.

**Musitech**™ is a factory-authorized Moog Service Center. We service what we sell. We do custom mods.

### SHIPPING

All items are now shipped via UPS or PRIORITY Mail. Free shipping on prepaid orders, sale items, and where indicated.

*It's an exciting time to be involved in electronic music.*

## Musitech™

1631-A East 25th Street  
P.O. Box 3717  
Chattanooga, TN 37404  
(615) 624-5600

## Music equipment

PAIA 4700/J Modular series plus:  
(1) 8782 Keyboard and 8700 series  
(1) 5 octave pratt read keyboard with 8782 encoder, (2) 8782 D/AC's, (2) 8781 Quash, 3(3) Osc's, (1) 4712 reverb, (1) 4711 Mixer, (2) 4710 VCA/modulators (3) Road cabinets, (2) 4740 Env. Generators, (1) 4750 LFO, (2) 4771 power supplies, (1) hex VCA, all factory calibrated and tested will sacrifice at \$750 or Best offer; ARP Omni II - \$650 or Best offer, \$1200 takes all. Kevin Looney, E 314 Richmond, SunyAB, Amherst, NY 14261, (716) 636-5339.

DEVELOPE YOUR OWN SYSTEM! Leave your tape recorder at home! (1) Fully expanded 8700 computer comes with ROM burner, 2K RAM, 2716 ROM Socket, (2) 6522 VIA's to make 4 more I/O ports, Power Supplies and Documentation. \$250. Ray Roeder (415) 989-6725.

FOR SALE: Clavinet D6, needs tuning, ARP String Ensemble, Both Excellent condition, \$500 each. (201) 572-1455.

DIGITAL SYNTHESIZERS - 16 track recording system, 8 voices, 2 oscillators/envelope generator per note. Stereo outputs, with or without computer. Models start at \$1299. For information and demo send \$3.00 cheque/M.O. to: Keith Qureshi, 2530 McKay Ave., Windsor, Ontario, Canada, N9E 2P5.

## Parts

BASS PEDALS without electronics - Birch and pine with SPST switches made to withstand drug crazed rock musicians. Under \$150. Send SASE to Ralph Boswell Musicial Instruments, P.O. Box 767, Metuchen, NJ 08840

SSMT ICs for sale. FREE SHIPPING with purchase of 4 or more. also, op amps, plugs, jacks, sockets, capacitors, switches, potentiometers, etc. Send for Free parts list. SOUND LOGIC, Box 49331, Austin, TX 78765.

## Recordings



★★★★NOW.....  
ON C60 CASSETTE:  
SYNTHETIC FOUR  
ELECTRONIC MUSIC  
If you like the style of Larry Fast and Patrick Gleeson:  
Try the style of:  
SYNTHETIC FOUR.....  
\$4.95 to.....  
Steve Meehler  
1610 J Ave NE  
Cedar Rapids, IA 52402

## Coming in the October issue:

**Micro Drums Part II, DON'T MISS IT!**  
**Larry Fast Interview**



# PAIA STOMP BOX EFFECTS

AT LOWER THAN 1980 PRICES

These new stomp boxes from PAIA are designed to give electronic guitarists the highest quality effect at the lowest possible price. Cases are formed of heavy steel and covered with the most scuff-resistant baked-on finish available. All feature heavy duty switches for long life and electronic effect switching for pop-free punch-in and punch-out. All are high input impedance, low output impedance, non-inverting, low noise devices designed to meet all proposed FX standards. Each provides hour after hour of operation from a single 9 volt battery and provide automatic power switching; you'll never have to worry about forgetting to turn them off.

## HOT LYX SUSTAIN

Probably the most used effect by any electronic guitarist, a sustain unit is essentially an amplifier that automatically increases its gain to compensate for a guitar's normal decay characteristics. The result is the ability to hold notes and chords much longer than would otherwise be possible.

Hot Lyx gives you all the control you need, continuously variable sustain from just enough to make your Silvertone sound like a Les Paul to "pedal to the metal" controlled feed-back settings that give rock-guitar its "all-out" quality. Level control allows for either lower or higher volume levels when you're punched into the effect and can also be used as an over-drive control to give you the sweetest fuzz/sustain sounds you've ever heard.

No. 5710 HOT LYX Sustain . . . . . \$34.95 (3 lbs.)

## MIDRANGER™ Midrange Equalizer

Sure, your amp has bass and treble controls — but what about the all important midrange? When you need more sound from your axe than most amps can give, but don't have the bucks for a fancy equalizer, the MID-RANGER is for you. Featured in Craig Anderton's June 1982 Guitar Player column, this special purpose equalizer gives more presence and "punch" by providing continuously variable boosts of up to 12 db. at switch selectable frequencies of 90, 200, 1000, 2000 or 4000 Hz.

Designed for guitars, voice, rhythm boxes and keyboards, the MIDRANGER features High Input/Low Output Impedance, quiet electronic switching and single 9v. battery supply (not included).

MIDRANGER (tm) Cat. No. 5740 . . . . . \$32.95 . . . . . 3 lbs.

## 5750 — AXE GRINDER(tm)

A classic fuzz to FX standards.

The AXE GRINDER might be a pretty routine fuzz if it weren't for a couple of subtle but significant features. Like a Distortion Intensity Knob that provides smooth control of clipping from just a hint when you really get it on to pure square waves when you even think of picking.

And the Distortion Tone, Distortion Level, and Clean Level controls are like having a built in mixer and E.Q., letting you precisely set the amount of distortion and its tone as well as the mix of clean and distorted signal. You probably never realized you could get so many sounds from a "simple" fuzz.

The AXE-GRINDER also features totally pop-free electronic switching and adherence to uniform FX standards that allow any Effect to work with any other without concern for mismatch noises or phase incoherence. 9 volt battery power (not supplied). 5750 Axe Grinder(tm) Kit . . . \$29.95 . . . . 3 lbs.

## 5760 ROCKTAVE DIVIDER(tm)

Whereas most effects that alter the harmonic content of a signal can only produce or accentuate frequencies higher than the fundamental frequency produced by the instrument, the ROCKTAVE DIVIDER fills out your sound by adding in wave-forms that are sub-harmonics of those produced by your axe.

Compandor stages are used to stabilize input for reliable triggering of the divider circuitry and to impress the original dynamics of your playing onto the newly created subharmonics.

Independent level controls on the extracted fundamental and first and second sub-octaves allow you to produce just the mix you're after and master tone control lets you round the square wave sub-octaves off to near-sinusoidal purity.

The ROCKTAVE DIVIDER also features automatic power switching when in use, pop-free electronic cancel function and single 9 volt battery power source (battery not supplied). 5760 Rocktave Divider(tm) . . . . . \$39.95 . . . . 3 lbs.

ORDER TOLL FREE WITH VISA OR MASTERCARD  
1-800-654-8657

DIRECT MAIL ORDERS & INQUIRIES TO:

**PAIA Electronics, Inc.**

1020 W. Wilshire, Oklahoma City, OK 73116 - (405)843-9626

QUALITY  
EFFECTS  
AFFORDABLE  
PRICES





# Introducing

# The Drumulator

from E-mu Systems, Inc. A digital drum computer with an amazing new feature.

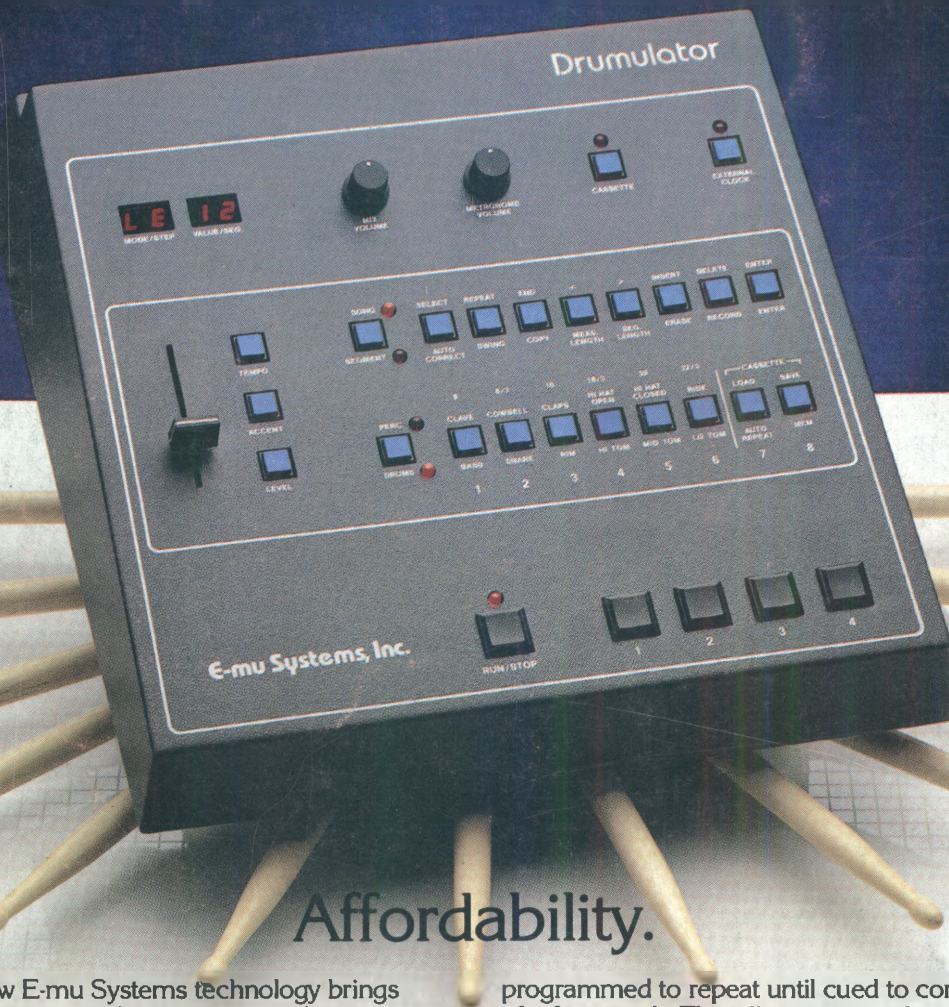

## Affordability.

The Drumulator. Now E-mu Systems technology brings you a digital drum machine with features you don't expect. At a price you won't believe.

With the Drumulator, you'll create complete rhythm tracks with the digitally recorded sounds of real drums. The Drumulator's computer makes it easy to program complex rhythms in any time signature. It will even correct timing errors in your playing.

The Drumulator's enhanced programmability gives you precise digital control over virtually every musical parameter. With its programmable mixer you can store and instantly recall a completely different mix for each rhythm track that you create. The tempo of each track can also be programmed, along with tempo changes within the track.

The Drumulator's unique programmable dynamics offer expressive capabilities never before possible with an electronic drum machine. You have access to normal and accented versions of every sound, with the accent levels independently programmable for each drum, cymbal, and percussion instrument. What's more, these accent levels can be programmed differently for each song and, like the mix, stored in memory for instant recall.

For flexibility in live performance, the Drumulator allows you to define sections within each song that can be

programmed to repeat until cued to continue by the press of a footswitch. This allows you to change the length of a song each time it's performed, shortening or lengthening solos, or repeating choruses as many times as you like.

Add to all these features the ability to sync to tape or other sequencers, assignable play buttons, external triggering from drum synthesizer pads, and individual channel outputs, and you have a digital drum computer that would be an amazing value at \$1990.00. But what's even more amazing is that for \$1990.00 you would get something that you probably wouldn't expect.

Two Drumulators.

*The Drumulator's suggested list price in the United States is \$995.00.*

**E-mu Systems, Inc.**  
applied magic for the arts  
2815 Chanticleer, Santa Cruz, CA 95062  
(408) 476-4424