

Polyphony^{T.M.}

\$2.50

ELECTRONICS-MUSIC-HOME RECORDING

October 1983

BASIC FILM SCORING MATH

LARRY FAST INTERVIEW

FOSTEX X-15 REVIEW



ISSN: 0163-4534

T H E O B E R H E I M S Y S T E M

"Let me overturn a myth here—this is the greatest drum box for sound and programmability..."

Stewart Copeland
(The Police)
Melody Maker
June 18, 1983

"The system inspires creativity and experimentation on every level."

David Sancious
May 27, 1983

"In truth, these three little boxes (DMX, DSX & OB-8) will do far more than we yet know how to make use of musically."

Jim Alkin
Keyboard/April 1983

"There's no other way to record a symphony by yourself..."

Sting (The Police)
Musician/June 1983

"The interface with the DSX exponentially enlarges the possibilities of what I can do."

Jeff Lorber
Obernotes/Fall 1982

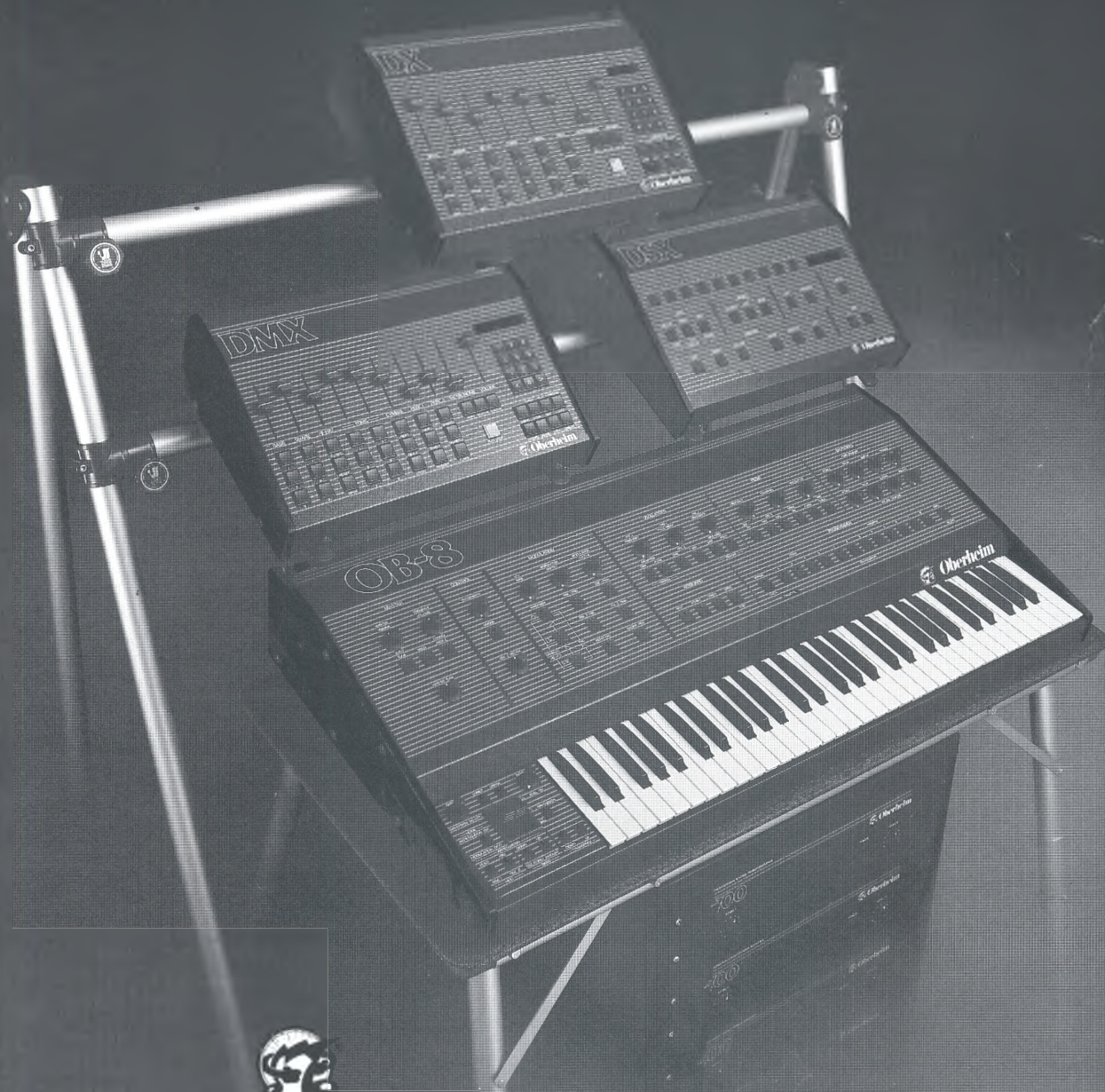

**OBERHEIM
ELECTRONICS, INC.**
Some things are better than others

2250 So Barmington Ave.
Los Angeles, CA 90064

DX Digital
Drum Machine
\$1395.00
Suggested retail

DMX Digital
Drum Machine
\$2895.00
Suggested retail

DSX Digital
Polyphonic
Sequencer
\$1995.00
Suggested retail

OB-8 Polyphonic
Programmable
Synthesizer
\$4395.00
Suggested retail

700 Professional
Stereo
Power Amplifier
\$895.00
Suggested retail

STAFF

PUBLISHER
John S. Simonton, Jr.

EDITOR
Craig Anderton

MANAGING EDITOR
Linda Kay Brumfield

TECHNICAL ILLUSTRATOR

Caroline Wood

CIRCULATION
Ramona French
Peggy Walker

BOOKEEPING
Cathi Boggs

PRINT PRODUCTION

Phuong Nguyen
SEMCO Color Press

POLYPHONY (ISSN 0163-4534) is published bimonthly at 1020 W. Wilshire Blvd., Oklahoma City, OK 73116, by Polyphony Publishing Co. Entire contents copyright (c) 1982 by Polyphony Publishing Co. All rights reserved. No portion of this publication may be reproduced in any manner without written permission from the publisher. Second Class postage is paid at Oklahoma City, OK 73125.

ADVERTISING rate card and deadline schedule is available upon request. Contact Linda Brumfield at (405) 842-5480.

DEALERS & DISTRIBUTORS bulk prices are available upon request. Contact Linda Brumfield at (405) 842-5480.

SUBSCRIPTION rates:
American 1 year \$12.00
 2 years \$22.00
Foreign 1 year \$14.00
 2 years \$26.00

We now accept MasterCharge and Visa payment for subscriptions, back issues, and PolyMart items. Foreign payments must be by charge card, money order, or certified check in US funds drawn on a US bank.

BACK ISSUES are available at \$2.50 each ppd. Send SASE and request our 'Back Issue List' for a complete index of issues and their features, or see the back issue ad in this issue.

CHANGE OF ADDRESS notifications must include your former address and zip code, and any numbers from the mailing label, as well as your new address. When you move, be sure to notify your post office that you DO want second class and controlled circulation publications forwarded. This will save lost or returned issues. Polyphony is not responsible for replacement of lost or returned issues when we have not been supplied with change of address information.

TO POSTMASTER, send address changes to:

POLYPHONY
PO Box 20305
Oklahoma City, OK 73156
Ph. (405) 842-5480

CONTENTS

ISSN: 0163-4534

Polyphony

VOLUME 8, NUMBER 6

OCTOBER, 1983

FEATURES

Basic Film Scoring Math By: Dr. Maury Deutsch	24
Build the Hip Bass Drum By: Craig Anderton.....	13
E-Mu Systems Drumulator Trigger Modification By: Kevin Monahan.....	28
Fostex X-15 Review By: Tom Mulhern	22
Index to Volume 8.....	33
Larry Fast, Interview By: Craig Anderton	8

COLUMNS

Applied Synthesis: Orchestral Voicings Using the Tenth Interval By: Bill Rhodes	16
Practical Circuitry: Micro Drums part II By: Tom Henry	18
Review By: Robert Carlberg.....	6

REGULARS

Ad Index	34
Current Events	29
Equipment Exchange Classified	34
Letters	4

ON THE COVER: The Gleeman Pentaphonic Clear - visible electronics.

COVER PHOTOGRAPH by: Vesta Copestakes - Vesta Advertising, Inc.
Santa Rosa, CA

Letters



Need an amazing source of synthesized sounds at an absurd price? Here you go... a noise oriented pre-patched minisynthesizer built around a powerful LSI chip.

The **Dark Star** provides a digital noise source with variable clock, plus a noise filter, LFO, VCO, VCA and envelope generator; a whole panel of synthesizer modules in just a tiny 6" x 4" x 3" package. It can be powered from +5, +15, or +9 volts (battery), is a nice beginner kit and requires only an external amp.

You can use it to simulate all those surf, wind, rain, cymbal, explosion, spaceships hurtling across the void and warping out type sounds. Careful design and wide range controls give you a real sound exploration tool; don't be fooled by the low price. Try it as a percussion kit addition, a drone voice, even as a CV source. The Dark Star just doesn't sound like anything else—we guarantee it! PRICE: \$49 PPD

BLACET RESEARCH, 18405 Old Monte Rio Rd.
Guerneville, CA 95446



The new Series V Digital/Analog Keyboard Controllers from PAIA offer enough standard features and options to fill every need from stage to studio. Standard features include Pitch & Modulation Wheels, Gate and Re-trigger outputs, Low Note Rule Priority, Smooth Pratt-Read Action, Light weight and only 2" high.

You have your choice of:

- 37 or 61 Note Actions
- Exponential Or Linear C.V.
- MIDI or Parallel Digital
- Mono or Poly
- Factory Assm. or Low Cost Kits

Best of all, prices start at less than \$180

call our toll-free line

1-800-654-8657

9AM to 5PM CST MON-FRI

for price & ordering details
& get your free PAIA catalog!

Direct mail orders and inquiries to: Dept. 11

PAIA Electronics, Inc.

1020 W. Wilshire, Oklahoma City, OK 73116 (405)843 9626

CALLING ALL TAPES...

I currently produce a weekly, three hour radio program here in California that is dedicated to new electronic/acoustic musics. I encourage any Polyphony readers to send me air quality reel-to-reel tapes (no cassettes!) for consideration.

Jon Iverson
1931 Nancy Avenue
Los Osos, CA 93402

EDR MODS?

I own an Echo Digital Recorder (made by Imagineering Audio, since out of business) and have heard that there is someone who is modifying them for improved fidelity. Also, I'm trying to locate a pedal to sweep the EDR VCO for flanging, as well as foot controls for live use. I also need a schematic! I am not the only EDR owner in the Seattle area with these needs, and we are collectively seeking this information. I know you are busy but Polyphony is my last hope.

Jim Billington
Carnation, WA

Jim -- The person you have heard of is probably Keith McMullan from Zeta Systems (1122 University, Berkeley, CA 94702). While not affiliated with the company that made the units, he is very familiar with the circuitry and has come up with some accessories (such as foot controls) for the EDR. A control voltage pedal is simple: plug a 9 volt battery into the input of a standard volume pedal (+ to hot, - to ground; if you're using a battery connector, red goes to hot and black goes to ground). Run a cord from the pedal output to the VCO input. Sweeping the pedal will present a 0 to +9V voltage change at the pedal output, sufficient to sweep the VCO over close to an octave range.

CORRECTION

Re the "Log Response LFO" (April 1983 issue of Polyphony), pin 7 of the 2209 should be pulled up to 15V through a resistor. The exact value depends on the desired output impedance; 1k is about the lowest you can go. Without this resistor the triangle wave will come out fine, but the square wave amplitude will be real low - about half a Volt, if that.

Ole Kvern
Seattle, WA

In the April '83 issue, page 35, "Meet Sid": The table 1 register map is incomplete. For registers \$04, \$0B, and \$12, D6 should be a square wave, D5 should be a sawtooth wave, and D4 should be a triangle wave.

Lon O'Bannon
Columbia, MO

AMS-200?

A few months ago I ran into an issue of Polyphony and ordered the 12 back issues of DEVICE. I was quite pleased with what I got. Is DEVICE still being run?

Also, I'd like to know how you solved the problem of converting a guitar's hex pickup signals from frequency to voltage. When I saw your articles in DEVICE on the AMS-100, I decided to go polyphonic and order a hex pickup from Roland; I like the AMS-100 approach to signal processing, and would like to add VCOs to my setup. I also intend to integrate PAIA's Shepard Function Generator into my guitar synth by multiplexing the pre-processed hex pickup signals through a series of VCFs and VCAs. And, whatever happened to the polyphonic AMS-200?

Mark Davis
Marquette, MI

Mark -- I am always amazed by the continuing interest in the AMS-100, which was intended as an experimental system. Several people have urged me to update and redesign the AMS-100. While time limitations have prevented me from taking on this large a project, I hope to return to it soon.

As far as VCOs go, I really see no need to re-invent the Roland GR-300 -- it really does just about everything I want a guitar synthesizer to do. However, a hex processor like the AMS-200 remains to be invented; I would base one on one of the existing GR-series guitars. I would not use VCOs, but rather, extract the fundamental through the compressor/filter/dynamics generating circuitry featured in PAIA's "Roctave Divider", then apply VCFs and VCAs.

Basically, what happened with the AMS-100 was that after building the thing, I started using it extensively in the studio. Over the past few years, I've found out which sounds, controls, and features seem most musically useful. Now I'd like to take what I've learned and make a more streamlined, easy-to-use system as well

as the AMS-200 polyphonic version. I certainly couldn't predict when all this will come about, but it is something I want to do, and I'm sure will eventually get done.

SID AGAIN

Having built only a handful of kits, and having read about analog delay circuits ("not for the beginner", "this circuit should not be attempted by the novice", "do not remove under penalty of law", etc.), I nevertheless decided to burn up one of your Hyperflange + Chorus kits (cheaper than burning one up from somewhere else). I put it together in three nights' work, calibrated it by ear, and I am very pleased with it -- no trouble at all, very quiet and lots of fun.

Regarding the SID 6581 article, it seems to me that Mr. Lisowski equates timbre with amplitude (twice!). I thought timbre depends on the relative harmonic content of a tone.

Also, would you explain how the "logical ANDing" of a triangle

and sawtooth wave works?

Ronald Parker
Norcross, GA

Ronald -- Glad you like the Hyperflange + Chorus, I blew up plenty in the design process so you wouldn't have to!

Re SID, you're right about timbre -- it is independent of pitch or volume. Re logical-ANDing, this means that the signals are not mixed in an analog fashion, but rather, that they modulate one another to produce a more complex overall timbre.

Modify

PAIA Programmable Drum Set

Roland Drumatix

E-Mu Drumulator Tuning Mod

NEXT
in Polyphony
ELECTRONIC MUSIC & HOME RECORDING

Be Creative With Real Sound

If you own an Apple or Apple compatible computer you can be creative with real sound in a new way. DX-1 is a hardware/software product for your Apple computer that lets you record, process, playback, save to disk, and generally modify ordinary sound in ways never before possible. DX-1 has certain musical abilities, and many creative sound manipulating abilities.

★★★ Features ★★★

- ★ Record, Process, Reproduce Real Sound Under Computer Control.
- ★ Includes Many Software Routines for Creative Sound Processing.
- ★ Includes Programmability of Sound Sequence, Length, Duration, Direction & Volume.
- ★ Includes Random & Preset Software Routines.
- ★ 8 Bit "Sound Sampling" Technique Used.
- ★ On Board High Fidelity Pre-Amp Lets You Interface to Almost Any Signal Source.
- ★ Includes P.C. Board, Diskette, Manual, and Connecting Cable.
- ★ Includes Pre-Recorded Drum Sounds, Miscellaneous Sounds, and Electronic Sounds.
- ★ Excellent Frequency Response, Hear it to Believe it.

Call For a Pre-Recorded Demo: (408) 735-0410

See DX-1 at your Apple dealer or order direct from Decillionix. Call or write for more info. Send \$239.00 check or money order + \$3.00 shipping & handling (CA res. add 6.5% sales tax).

Decillionix

P.O. Box 70985, Sunnyvale, CA 94086 (408) 732-7758

APPLE is a registered trademark of APPLE COMPUTER INC.

Dealer Inquiries Invited



NEW GUITAR CHORD COMPUTER

Quick. Think of 3 ways to play a D flat 9th chord. Give up? The **GUITAR CHORD COMPUTER** shows you all three in less than 10 seconds. Virtually every guitar player can use one of these. Here's what it will do: **CHORDS** Major, Minor, Dominant, Augmented, and Diminished; **SCALES** Major, Harmonic Minor, Melodic Ascending, and Melodic Descending; **ALTERNATES/INVERSIONS** 3 and 4 alternates are shown for most chords (Easiest to play is displayed first); **TRANSPOSE** Up or down by half-steps; 6th, 7th, 9th **CHORDS** Displayed at the touch of a button. Play better and easier guitar in minutes. Order yours today! **No. CC-2 Guitar Chord Computer** \$59.95 (plus \$2.50 postage & handling)

CHARGE TO VISA OR MC TOLL-FREE
1-800-654-8657 9AM to 5PM CST MON-FRI

Ask for your free catalog.

Direct mail orders and inquiries to: Dept. 12Y

PAIA Electronics, Inc.

1020 W. Wilshire, Oklahoma City, OK 73116 - (405) 843-9626

PLUG INTO

Polyphony

FOR
ELECTRIFYING IDEAS!
DON'T MISS AN ISSUE
SUBSCRIBE TODAY!

() One year \$12 US/\$14 foreign
(6 issues)

() Two years \$22 US/\$24 foreign

Name: _____

Address: _____

City: _____ state: _____ zip: _____

VISA/ Mastercharge accepted.

Card No. _____

Expiration date: _____

(signature) _____

Mail to:

POLYPHONY, P. O. Box 20305

Oklahoma city, OK 73116

Robert Carlberg's

re-view

Various The Musician's Tapes (cassette). This project started out as a Serge demonstration tape, but according to the notes so much good music was submitted that there wasn't any room left for the sales pitch. So we get 75 minutes, 22 selections, from a Bach Concerto to rhythmic dances to left field bumps in the night. In the process it clearly demonstrates there is no "Serge sound" -- real testimony of their flexibility. Complete notes by the composers, the appearance of several other instruments, and of course the lack of a sales pitch make this more than a demo tape though -- it's a full-fledged anthology. \$6 plus postage from Serge, 572 Haight St., San Francisco, CA 94117.

Brian Eno Apollo (Editions EG Eno 5). Subtitled "Atmospheres and Soundtracks", this is the score to a documentary on the moon landings. Motionless sound portraits, consisting of unrecognizable slowed-down shapes and shadows, these must be a perfect complement to the NASA footage. In the silence of space, the only sounds are the internal symphonies of the mind. One imagines Eno captures them well.

Cybotron Enter (Fantasy 9625). This is the Detroit Cybotron, not the Australian one (who have four albums of their own). This one consists of Juan Atkins on synthesizers and vocals, and two associates who may or may not be human: Jon-5 on electric guitar and 3070 on electronics and vocals. The music is pretty straightforward electropop built on rhythm box, keyboard synthesizers, and vocoded vocals. Most of the tracks might qualify as "dance mixes".

Cybotron Cybotron (Clear Light of Jupiter 782); **Sunday Night at the Total Theatre** (CY-6542); **Colossus** (Champagne 7004); **Implo-**

sion (Cleopatra 203). From Australia, one of the first groups to combine synthesizers with a rock beat. The first and live albums are as a duo (synth and synth/sax) plus a rhythm box, and tend toward phase shifted chords and simple tunes over a mechanical beat. The next two take a big step forward by going to a real drummer and more complex song structures. The sax trades off with the synths in carrying the lead for sort of a hard-rocking camel.

The Police Synchronicity (A&M 3735). The best-selling album ever by the most popular band in the world. Like the Beatles, the Police know exactly what they're doing, and do it so well that we don't feel manipulated (or cheated). The comparison works on several levels.

Bernard Szajner Brute Reason (Island 9735). In the best of all possible worlds, this is the kind of stuff that would go platinum. Like his earlier discs (Jan/Feb '81, May/Aug '82), it's challenging and beautifully logical all at the same time.

Geoffrey Landers Habitual Features (Local Anaesthetic 02). A slightly edgy collection of electronic rock tunes makes up side one, and a 20-minute piano and jutting synthesizer piece fills side two. Both rely on the tension of the angular synthesis to allay any fears of its becoming "ambient" -- so enjoy the irony of the label name. 116 S. Lincoln St., Denver, CO 80209.

Lauri Paisley MemorExodus (cassette). Neo-classical themes and flourishes on keyboard synthesizers somewhat like Larry Fast without the extended development. \$6 from Lauri at 947 James Street #1, Syracuse, NY 13203.

continued on page 12

PLAY DRUMS AND GUITAR-AT THE SAME TIME?

Yes!! with Electro-Harmonix' new **INSTANT REPLAY** you can accent your playing with any sound under the sun.

Glass breaking, a chord or lick from a guitar or synth, *real* handclaps, vocal sounds like burps, yells or singing — ANY sound that can be picked up by a microphone, produced by a guitar or other electronic instrument or transferred from tape!!

Push a button on the **INSTANT REPLAY**, a red LED comes on and you're ready to record. You can now input up to 2 seconds

of any sound you want into the unit's digital memory. That same sound can then be *instantly* replayed by hitting the external drum pad that comes with the **INSTANT REPLAY**. The pad is touch-sensitive, so a harder beat produces a louder sound, and the *pitch* of the sound can be transposed if you like — make your voice sound like Darth Vader or The Chipmunks! A continuously looping replay of the sound is also possible, providing an opportunity for sequenced or metronomic effects.

The **INSTANT REPLAY** isn't limited just to drummers. Guitarists and keyboard players can trigger the replay with a tap of the hand or foot, INSTANTLY generating the creative, unique sounds that have been stored in the unit.

The **INSTANT REPLAY**, available at leading music stores throughout the world, gives you access to sounds and effects previously obtainable only on the Fairlight or Emulator, but at a small fraction of their cost. It comes with all necessary hardware to mount on Roto-Tom and most brands of cymbal stands.



ELECTRO HARMONIX

The Best Sounding Effects In The World!!

27 West 23rd St. • NYC, NY 10010 • (212) 741-1770

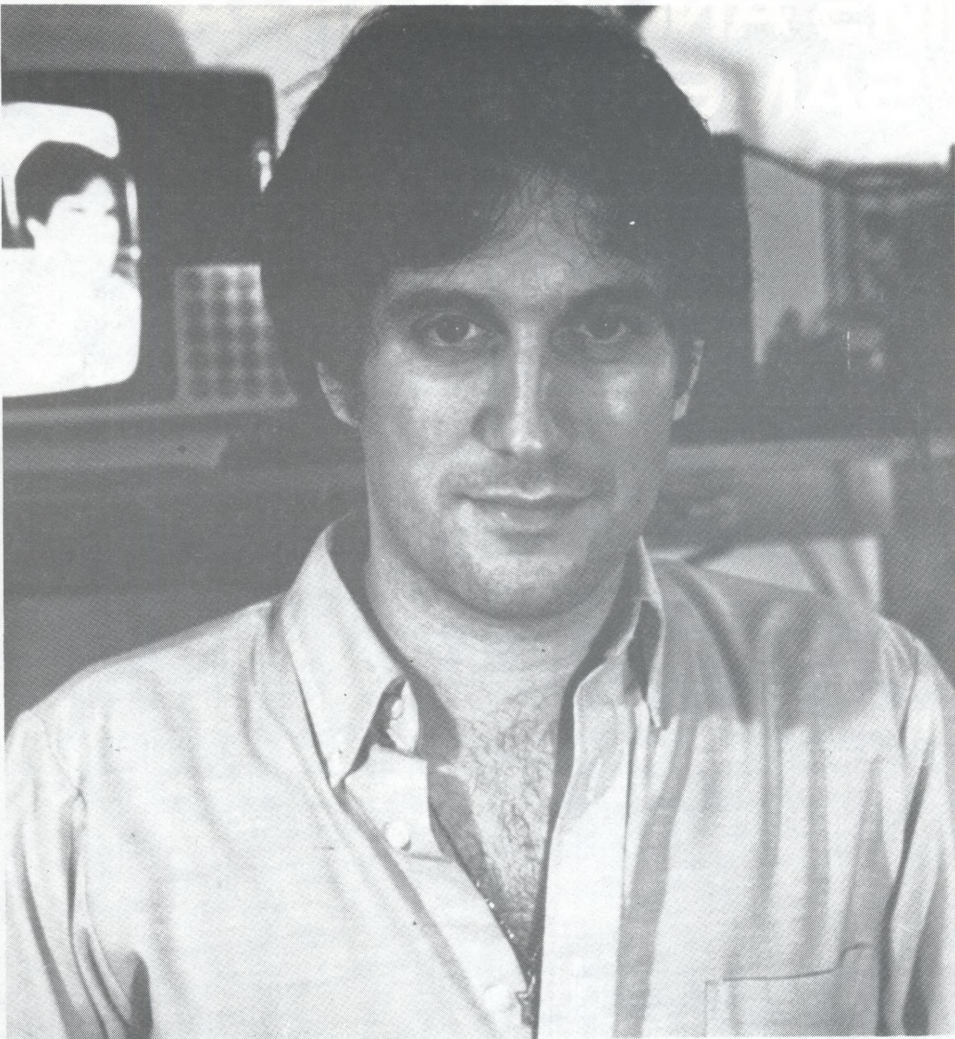

LARRY FAST

Interviewed by
Craig Anderton

— *It's very nice to record at home.* —

Larry Fast probably doesn't need much of an introduction to Polyphony readers, as he has consistently been in the forefront of musical electronics. His solo albums under the "Synergy" name, his daring work with Peter Gabriel, and his many sessions with artists as diverse as Foreigner, Hall and Oates, and Joan Armatrading have established him as a commercial and artistic force in the field of synthesis. As if that wasn't enough, he has recently branched out into film scoring and video production.

Larry brings a very professional attitude to his music, but anyone who takes Larry's music too seriously would be missing a lot of what makes him tick. Those who feel his Synergy albums have, on occasion, tended towards excess would probably feel differently upon meeting Larry in person; his sound is not the product of trying to impress anybody, but rather, the result of what happens when you turn someone with his level of excitement and enthusiasm loose in the studio and impose few -- if any -- commercial restraints.

Yet there is more than one musical attitude to Larry Fast. On his work with Gabriel, for example, Larry is always extremely tasteful and supportive -- almost underplayed. In fact, the more you get to know Larry, the more you recognize that there are many facets to his personality, and that any given piece of his work is only one glimpse of a larger whole. In this interview -- the first full-length interview with Larry in several years -- he talks at length about the diverse elements that make up his musical personality and style.

CA: How did you get from being a college student to working with Peter Gabriel?

LF: I was working in college radio, which naturally put me in contact with the record business. The connections that existed from the college radio days and the outgrowths of those connections helped lead to the Synergy albums, which led me to Gabriel.

CA: What exactly do you mean by connections?

LF: In those days, the people who were just starting out at record companies were generally put in college radio promotion departments. Many of them moved up

within their companies to positions in talent acquisition and A & R, and are now the people I deal with when I work as a session musician with acts on their labels. Basically, a sort of "old boy" network was established back then between the eager people trying to get into the record industry on the performing side, like me, and those that had just entered it on the promotion side. I ended up signing with one of the young hungry companies -- JEM records -- and they released the first Synergy album on their Passport label.

I had been working in an electronics company and doing music on the side ... gradually the music became a more and more important part of my life.

The reason why connections are important is that people very rarely get signed from sending tapes to companies; since I was already a bit known within the industry, instead of having to go through the whole bit of submitting demos there were specific people to whom I could say "here, I've got some tapes of what I've been doing -- would you care to have a listen?" Even signing for the first album didn't change my life overnight or anything; I had been working in an electronics company and doing the music on the side, and gradually, the music became a more and more important part of my life.

CA: What kind of electronics company did you work for?

LF: An importer of Japanese manufactured goods for chain stores...stereo equipment, that kind of thing. I worked for them during summers while in high school, through college, and then after graduating from college lived off the job while preparing the Synergy project.

CA: I'm sure that will encourage some people...

LF: ...and probably discourage others! It doesn't really happen that you're playing in a bar with a hard working band, and the record company guy comes in and sees you, and says "This is going to change the world, we'll sign you on the spot". It just doesn't happen like that. There are channels of power that flow in the record industry, and knowing how

those work is more important. The art will always be there -- that happens independent of business. The business is about distributing that art.

CA: When did you feel secure enough in your musical career to leave your job?

LF: The funny thing is that I never formally resigned. I took a leave of absence to do the first Synergy album, and then over a period of time I began taking more lengthy leaves, and worked things down to a very part time position. It was a gradual drifting out of one money making venture into another as the new one was able to take up the slack. As the first royalties started coming in from Synergy, I found I could start living off my music.

CA: When did you record the first Synergy album?

LF: It was begun right at the beginning of 1975 and released about six months later.

CA: It was recorded with pretty minimal equipment, wasn't it?

LF: Yes, especially by today's standards.

CA: How did the album do initially?

LF: Pretty well -- it got up to number 60 on the Billboard charts. This was a little bit better than I expected, since I was pretty cynical about the way the record industry power structure operated. I was definitely surprised it did as well as it did.

CA: To what do you attribute that?

LF: It's hard to say but (laughs) it was probably due to good promotion.

CA: Where you playing live at that point to promote the album?

LF: No, it was mostly interviews along with radio station visits with promotion people. Also, shortly after the album was released, but before the promotion really got going, I went to France to work with Nektar on their "Recycled" album. They were just coming off the top 20 in 1974, so there was also the added connection there, and we were sort of promoting each other as they were just beginning their touring career in the U.S.

CA: Did you tour with them?

LF: I did my first touring in 1976 with Nektar to promote their album, and we worked out a cross-promotion where the Synergy albums were the play-in/play-out music.

Their light show also displayed Synergy graphics, which was pretty blatant advertising but it worked.

CA: Did you like touring?

LF: Oh yeah, even if it wasn't my music.

CA: After completing the second Synergy album in 1976, you met Peter Gabriel. How did that come about?

LF: Again, a variety of connections. First, Passport was handling Brand X and some of the other Genesis spin-off material. Second, Bob Ezrin, who was producing Peter's first album, was friends with one of the main equipment suppliers for House of Music studios, and I was rapidly becoming part of that organization. Also, I had a growing reputation in electronic music and Peter was aware of that. We had an exploratory meeting as he was preparing production on the album, and hit it off right away. Never looked back -- we're still doing it.

CA: What is your exact function with Gabriel?

LF: Actually, it's a very hard thing to put a handle on. In the shows, I'm really just one of the members of the band. Peter's style of music is heavily based in electronics so I do have a rather important role, but not necessarily any more important than any of the other players. When recording, Peter's got a very good electronic mind and is well-grounded in many electronic techniques; I guess what I bring to the process is some additional experience in electronics. I'll give a second opinion, or sometimes, a first opinion to which he can give a second opinion. There is also an element of production in what I do -- my credits, on the last two albums have been for electronic production, which covers anything from processing the sound of conventional instruments to patching a synthesizer.

CA: Did you have any influence in getting Gabriel to his more rhythmic/ethnic musical orientation?

LF: Well, Peter was beginning to make noises about working with a drum machine -- the kind of drum machine where you could pattern the sounds yourself. At the time there really wasn't anything like that except for the PAIA drum box, so I put Peter in touch with one of those machines. That led to a lot of the rhythms that showed up

on the third album, especially "Biko"; subsequently, machines like the Linn appeared and Peter moved on to those more sophisticated devices. But the PAIA drum box was the real genesis of Peter's interest in new rhythms. It led to a whole approach to writing.

CA: I noticed that the band is heavily into wireless technology. Did you have any input into that?

LF: Well, we all kick ideas around -- whoever thinks of something will mention it. I believe the wireless was Peter's idea.

CA: So the band is pretty much a free, give and take situation?

LF: Yeah. It really is. Peter's the focus of it, but the whole package is closer to a true band situation. In comparison to people that I know who work with other acts -- such as David Bowie or others -- we are a more of a democratic band.

CA: Do you think that's the way to go?

LF: I think it depends on the artist. For the Peter Gabriel Band the democratic approach makes the the best use of everybody's talents. Then again, we all have fairly significant careers outside of the Peter Gabriel Band -- Tony Levin (bass) also plays in King Crimson, and we all do lots of session work for other people. Besides, Peter is one of the easiest people to get along with. He's got very definite ideas, and he gets stubborn about them sometimes, but he's very open to new thinking. You couldn't ask for somebody better to work with.

CA: What kind of equipment have you been using on the current Gabriel tour?

LF: The big showpiece is the Fairlight, but I'm also using a Memorymoog and Prophet-5. Hopefully sometime during the tour they will be retro-fitted with MIDI interfaces. (See the June 1983 issue of *Polyphony* for more on MIDI -- Ed.) I'm really looking forward to MIDI because both the Memorymoog and Prophet-5 are strong in different areas due to slightly different design approaches, and I want to be able to blend them in an intelligent sort of way. I had been using the PAIA

I'm really looking forward to MIDI ... I want to be able to blend (my instruments) in an intelligent sort of way.

The Fairlight is not just a big Mellotron.

8700 computer as a sequencer, but now I have a Moog Source -- it has battery back-up on the sequencer memory, which makes it much easier for the crew to set up every day. The more complicated sequencing is done on the Fairlight.

CA: What is the Fairlight's main function?

LF: I use it on about half the songs, primarily for stored sounds and manipulated stored sounds. I do a lot of sampling (digitizing and storing) of sounds, but very few of the sampled things are left as is. They're manipulated on "Page 4" and other related pages within the Fairlight operating system, so they don't really resemble the sounds that were stored originally. The Fairlight is not just a big Mellotron.

CA: Is the Fairlight reliable? Does it hold up on the road?

LF: It's been remarkable. Only once did we ever think we had a serious problem with it; it turned out that the power in the hall was very low, about 94 Volts, and the Fairlight was the first instrument to show any symptoms. The electricians tried to jury-rig the electrical system to make it work, but it still failed about two-thirds of the way through the show. The voltage dropped down to about 80 Volts, and just about everything packed up at that point -- the lights and all the synthesizers, except, surprisingly enough, for the Memorymoog. I don't know how it survived so well. Luckily the low power didn't do any permanent damage to anything.

CA: Are power problems common enough that you have to use devices such as uninterruptible power sources?

LF: They sure help. It's a little better nowadays thanks to battery back-up instruments; it used to be a little dangerous when you could only load memory from data cassettes, because if the power went down, you had to reload everything and start over.

CA: What kind of signal processors do you use?

LF: I've got a rack of processors, including an old MXR graphic equalizer; Delta Lab DL-2 acoustic computer with one extra memory module in it; an old Eventide Harmonizer™ which is nasty, dis-

torted and hissy but still sounds great; and a Roland Dimension D, which I like because it adds a very subtle effect. It doesn't hit you over the head with its phasing and flanging...it's good for synthesized ambience. Finally, there's a little mixer panel and a bus routing structure that I designed. On stage I add my own effects to the instruments, and then send the stereo submix down to the main house mixer.

CA: You mentioned a couple of devices you made yourself. Do you do much custom building?

LF: Yes, quite a bit. With the Moog modular system -- which doesn't tour anymore because it's not as practical these days as some of the other things -- I went so far as to order one of the Moog housings with a whole bunch of blank panels, and built several modules to supplement the commercially manufactured items.

I gravitated toward electronic music in the first place because of my background as a tinkerer, hobbyist and general electronic weirdo.

CA: How did you get into building? Was that an outgrowth of the music, or was necessity the mother of invention?

LF: A little bit of both, actually. I think I gravitated toward electronic music in the first place because of my background as a tinkerer, hobbyist, and general electronic weirdo. It's hard to say whether music or electronics is the dominant interest -- I have very strong feelings for both.

CA: Do you think that it's important for musicians to be able to do their own building, and otherwise develop some electronic "chops"?

LF: No, I actually think that understanding computers is going to be more important. I find I've been doing less and less hardware customizing or building things like delays, trigger delays, and all of that. Rather than implement hardware changes in analog, it's easier to do software changes in a digital synthesizer, providing of course that you can get into the system.

Rather than implement hardware changes in analog, it's easier to do software changes in a digital synthesizer.

CA: How did you get your computer programming expertise?

LF: In college. I was probably the only history major taking electives in engineering and computers. I got through BASIC and FORTRAN in the early seventies, but when single chip micros became available they were ideal for what I wanted to do. Since higher level programming did not exist for the early micros, I was forced to learn machine code on one specific processor. That forced me to get good at programming, and everything else was easy after that.

CA: Are you pretty much in favor of the trend towards computerized instruments, or do you think it's taking things too far away from the human element to have electronic drum machines and similar devices?

LF: Pretty much in favor, as long as the musicians using this stuff are still able to maintain good artistic taste about what they're doing. I can't really fault the machinery if it's used in an un-tasteful manner.

CA: Despite the fact that digital drums are pretty trendy right now, it seems to me that analog drum sounds still have lots of potential. For example, you get some good synthetic analog drum sounds on the Synergy albums, particularly on the cut "Alien Earth" from the Jupiter Menace soundtrack. To what do you attribute the quality of these drum sounds?

LF: To tell you the truth, I don't really know. The sounds are all patched up, primarily with Moog modular equipment. There's nothing there that hasn't existed commercially since 1967, so there are no "secrets" or anything. It takes a little bit of work -- precise tuning, careful filter settings, and careful approaches to envelope control or whatever -- but nothing that couldn't be done with an off-the-shelf minimoog.

CA: There's no special filtering or anything?

LF: Well, I will go overboard on the EQ and bang the bottom end way up, and perhaps put a little extra top end on the sound to catch some of the strike tone but there's nothing mysterious about the sounds. They're just made out of noise and LFOs.

CA: Do you synthesize the various sound components of the drum separately -- like synthesizing the strike tone separately from the shell tone?

LF: Yes. Interestingly enough, there was an article in Polyphony a few issues back (the "Snare+", by Thomas Henry -- Ed.), and I was very surprised to see a lot of the techniques that I use covered in there.

CA: Let's talk a bit about you and the studio. How is your home studio set up, and what role does it play in developing your music?

LF: The home studio is more a part of Synergy than anything else. It's pretty well-equipped, and has an MCI one-inch/8 track recorder with dbx that can put out master quality tapes. There are lots of tables and shelves in the room, and all the equipment is ready to go at all times -- which I find to be a great way for me to work out compositionally. Everything is in one place, so I can work out my ideas, get pieces started on tape, and in some cases, complete them on the 8 track or be ready to do a 24 track transfer that will be studio quality.

It's very nice to record at home.

CA: Why don't you just start out with 24 track from the beginning?

LF: For one thing, it's very nice to record at home. The nearest 24 tracks are at House of Music, which is a twenty minute drive and besides, I would have to work around other clients. At home I don't even have to take the tape off the machine. Another aspect is that two-inch 24 track tape shuttles rather slowly compared to one-inch tape, which eats up a lot of time.

CA: Since you do touring, studio work, and film scoring, which do you like to do best?

LF: It's hard to say. Live performance is exciting, what with travelling and touring; it's fun, and I really enjoy it, but you can't explore new areas when you're on the road. You can explore slightly new arrangements on a given night, but you're doing pretty much the same thing over and over and over again, which limits your musical and intellectual growth. With session work, you're a little bit more at the whim of the producer or the artist, and have to give them what they want. Sometimes, if they're real good about it, they'll listen to what you have to say -- but in any case "the client is always right".

CA: What's the status of "The Jupiter Menace" soundtrack you completed some time ago?

LF: It's in limbo. VHS and BETA cassette versions of the movie have been released domestically, but they're not being promoted. As for theatrical release, I've heard so many mythological dates about when the movie is supposed to actually hit the streets that I have no real idea when it's coming out.

CA: Do you enjoy film scoring work?

LF: I found it to be quite a challenge, but a very enjoyable challenge. You're working with some pretty severe constraints on time, musical styles, timing cues, and all the other things that have to do with making a movie -- as well as the more common problems associated with making a record. Yet these constraints also force you to focus on what you're doing, and be very precise.

CA: Will it get to the point where people would buy a Synergy video cassette instead of a Synergy album?

LF: That's a possibility, because I've been dabbling with video editing and shooting, and I've done still photography for years. I have my own darkroom and the visual arts have interested me for a long time. I think I do have a good sense of visual imagery, but this is something I'm still working on and I wouldn't subject anybody in the public to it until I feel it's right.

CA: What else lies in your future?

LF: The immediate future is a lot of touring, since we haven't toured Europe or England or any of Peter's major markets since 1980 and that's not fair to the public. In the more distant future, there will be more Synergy albums as well as film and video sound tracks. And there will be continued exploration at the technical level, especially digital electronic sound and use of computers.

CA: What are your interests outside of music?

LF: Well, having a degree in history ties me into political science and governmental structures. I'm very interested in current events.

CA: Will those interests show up more in your music, or do you tend to keep music and politics separate?

LF: The connections probably

exist on a very subliminal level, but I think they're kind of separate entities for me. I don't think I'd end up putting even strong political feelings into a song. I think I'd make a better political writer or pamphleteer; I feel that would make a stronger impact than simply putting things to music.

CA: One last question. Is music a diversion, or escape, for you, or are you driven to make music...almost like a biological need?

LF: It's a pretty strong need. Music is something that has been

with me for as long as I can remember, and has always been very important in my life. I'm not sure know what the physical manifestations would be if I ever had to "withdraw" from making music, but I'm sure they would be pretty severe.

I'm not sure I know what the physical manifestations would be if I ever had to "withdraw" from making music, but I'm sure they would be pretty severe.

re-view

continued from page 6

Steve Roach **Now** (cassette). Steve Roach was a writer for Synapse and a member of Moebius, their house band. Aside from a track on "Music for the 21st Century" (reviewed May/Aug '82), this is his first solo release. Track two is a real nice free-form ring-modulator piece, track four has some lovely voice-like synthesis over very ethnic-sounding electronic percussion, and track five is backwards sax and flute which somehow manages to sound surprisingly unhackneyed. The other three tracks are improvised soloing over a rhythmic background of the sort made famous by T. Dream, Klaus Schulze, Michael Hoenig, Michael Garrison, and many others. Even these tracks are extremely well done, with imagination and taste. An auspicious debut. \$7 from Eurock Distributing, PO Box 4141, Torrance, CA 90510.

Various **International Friendship** (Syncord 002). From Italy, Denmark, Holland, U.S.A., Germany, and Japan, a diverse sampler on Rudiger Lorenz's label. One track by Rudiger, some minor involvement by Conrad Schnitzler, and it is not, shall we say, dance music. Also from Eurock Distribution.

Peter Baumann **Strangers in the Night** (CBS 38903). A new approach for new times -- gone forever are the dramatic instrumentals of the first two solos. Vocalist/co-writer Eli Holland brings a much more polished sound than on "Repeat Repeat" (panned Sep/Oct '82). I miss the old stuff, but this album's really pretty nice -- and yes, the title track really is the old Sinatra vehicle.

Jon Hassell **Aka/Darbari/Java** (Editions E.G. 31). "Aka/Darbari/Java" is a proposal for 'coffee-colored' classical music of the future -- both in terms of adoption of entirely new modes of structural organization and in terms of an expansion of the 'allowable' musical vocabulary in which one may speak". Not appreciably different from his other records, but that's fine with me.

continued on page 28

Electro-Harmonix Digital Delay



The new Electro-Harmonix Digital Delay is the first offering by the newly reorganized E-H, and if they continue in this vein, the company will really give the Japanese something to worry about.

First of all, this is the smallest long delay unit I've ever seen—you don't even need a rack for it. Secondly, because it has such a long delay time, which can be used to store sounds and play them back, you have, in essence, a "Fripp-in-the-Box," if you will—meaning that you can use this box to stimulate the tape loop effects that have made Mr. Robert Fripp famous, without two tape machines. Because you have such a long time between the time you play and the time it comes around again (from eight to sixteen seconds, maximum), you can sound like more than one player at any given moment.

As a matter of fact, one of the important functions of the E-H digital delay line is to overdub yourself live using the freeze function that takes whatever is in the "circuits" at the time and stores it. Then it plays it back right away. So you can

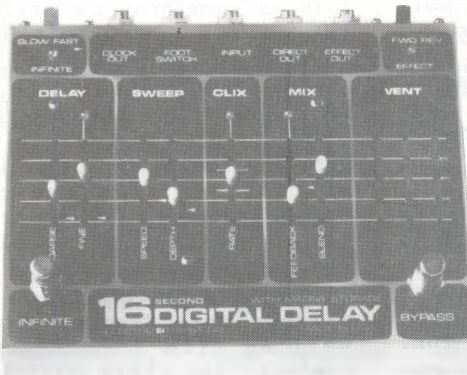

dub over that part, and layer it up. The designers have included a click track that you can hear, but which doesn't get recorded, to allow you to synchronize yourself. This unit also interfaces to the E-H line of deluxe rhythm boxes (and perhaps to some others) so that you can automatically sync the repeats to the tempo.

The E-H Digital Delay is also capable of producing a digital flange, which I like a lot. In sum, there is a lot that you can do with this unit, and in traditional E-H fashion it is priced at a half or a third of any similar unit. The unit is quiet, easy to use and easy to stow away in a shoulderbag.

—Peter Mengozio
March, 1983/Guitar World

The Digital also contains:

- **DIGITAL CHORUS** which can be used at the SAME TIME as the delay and flange.
- **REVERSE SWITCH**—Not only can you lay down up to a 16 second track, but with the flick of the reverse switch everything you played will instantly play BACKWARDS without losing a beat. And, you can then lay forward tracks on top of the backwards track—all while you're playing LIVE!
- **DOUBLE SWITCH**—Anything you lay down can play at half or double speed. And—you can lay down a normal speed track on top of the halved or double speed track—while you're playing LIVE!!
- You can sing through the Digital, laying down multiple harmonies on top of each other each time the unit passes through its 16 second cycle where it instantly starts looping at the beginning again—all without losing a beat—all while you're playing LIVE!!!
- You can invent a gigantic variety of unusual new sound effects of your own with combinations of settings.

Try the 16 Second Digital Delay at your favorite music store. If they don't have it in stock, they can get one shipped within 24 hours.

Mike Matthews
Electro-Harmonix

27 West 23rd Street
New York, N.Y. 10010
(212) 741-1770

electro-harmonix

Build the Hip Bass Drum

By: Craig Anderton

Getting a good bass drum sound in the studio is difficult enough, but getting it to "print" well on tape is even harder. The problem is simple: a bass drum, by definition, occupies the lower regions of the audio spectrum -- the regions where transducers (such as speakers) work least efficiently, where tape recorders have fairly severe response anomalies, and where it is most difficult for the ear to judge relative levels.

With respect to electronic drums, there are two popular ways to create a bass drum sound. One is analog synthesis, the other digital recording of a drum sound (a la Linn). While it might seem that digital recording techniques would produce the perfect bass drum sound, in practice quantization noise is more of a problem with low frequency sounds, and of course, you are locked into whatever bass drum sound the manufacturer thought sounded best (although some units, like the MXR Drum Computer, offer alternate sounds; and the tunability of devices such as the Oberheim and Linn units can also add welcome variations). Analog bass drum units present even more problems, as they are often simple damped sine wave oscillators which put out very few harmonics and hardly "cut" through a track at all. The solution? After a lot of work, I came up with the "Hip Bass Drum" (HBD for short). That may sound like an immodest title, but I wanted to make sure it was understood this drum unit does not sound like most analog bass drums -- nor does it sound like most digital bass drums, either. It has enough controls so that you can dial in just about any kind of bass drum sound, from low and resonant to high and "clicky" (perfect for the techno-poppers). The HBD gives excellent results

whether used as a stand-alone unit, or paralleled with a digitally recorded drum sound to add extra body and/or high frequency content (thus freeing you from having to use as much equalization on the digital bass drum sound).

How it works. IC1A accepts a positive-going input pulse (+10V is best, but +5V will do). For example, PAIA's "Master Synchronizer" generates pulses which are compatible with this device. C1 turns the pulse into a narrow pulse which becomes broader at its base. R8 is a pulse width control which varies the overall width of the pulse. Varying R8 alters the "thud" of the bass drum; a wider pulse width gives a heavier sound, as if you're slamming the beater into a bass drum, while a narrower pulse width sounds like the drummer has a lighter foot.

IC1B is your basic damped, sine wave oscillator, which is momentarily kicked into oscillation when a pulse hits IC1B via D2 and R21; however, there are also some significant differences from the norm. First, there's a tuning control (R9). But that tuning control is further augmented by a circuit that changes the resonant frequency dynamically over time. This occurs because the pulse appearing at IC1A's output passes through D1 and charges C2. R18 discharges C2 after the pulse goes away, which produces a short decay envelope. This causes Q1 to conduct, and since Q1 is paralleled with R9, the bass drum frequency transitions rapidly from a higher frequency down to the initial frequency set by tune pot R9. This happens so fast, however, that you do not perceive the frequency shift as a pitch change, but rather, as a highly complex attack sound. If you think about it a bit, pushing a beater into a bass drum head does in fact tight-

en the head (thus raising the pitch), and when the beater is released, the head falls back to its natural resonant frequency. Thus, this pitch change circuit helps to more accurately model an acoustic bass drum sound.

Still, a frequency change is not enough to create a strong attack sound (for more on this, see Thomas Henry's "Snare+" circuit in the Sept/Oct 1982 issue of Polyphony). So, to create an attack "click" that greatly increases the ability of the HBD to cut well on tape, we send the trigger pulse into IC1B's (+) input as well as into the other sub-circuits mentioned above. R10 acts like a simple tone control which varies the tonal quality of the click from muted to bright. R11 varies the level of the click, so that you can mix it in prominently or let it ride a bit in the back. This click is a very important component of the HBD sound, as it produces harmonics which cue your ear that a bass drum is being hit -- even if the frequency response of the playback system doesn't pass much of the fundamental tone produced by the damped oscillator.

Resonance control R12 varies (not surprisingly) the resonance of the drum. I usually leave this fairly "flat", but if you get adventurous and start using the HBD to synthesize low tom sounds, adding resonance produces a more satisfying simulation.

"Hard limiting" switch S1 is perhaps the most interesting (and most important) control in the HBD. LEDs D6 through D10 act as clippers for the positive, but not the negative, part of the drum's audio signal. Note that these LEDs are not panel LEDs, but are used for their clipping characteristics. The purpose of clipping is to add harmonics, while not

altering the "bottom" too much. Depending upon how much clipping you use, the effect can be subtle or drastic. This is the feature that is most responsible for giving a good bass drum sound on tape; try recording the bass drum with and without the hard limiter, and play the results over a system with poor low frequency response. The hard limited drum will sound more prominent and cut through a track better.

Concerning the monitor circuit built around Q2, C7 stretches the trigger pulse. This turns on Q2, which lights LED D5 (the only panel LED), and this indicates that the bass drum has been triggered.

Construction tips. The circuit is non-critical; a parts kit is also available (see parts list). You can use just about any kind of op amp for IC1A and IC1B, but I used a 4739 not just because

it's quiet but also because it seemed to have a "meatier" sound than bifet type amps (circuit design sure gets subjective sometimes...).

Other tips: Use good quality capacitors (polystyrene or mylar) for C1 through C6 to ensure stability and high sound quality, use red LEDs for D6 - D10, and try to provide a good, regulated +15V supply. All circuits like a clean source of power, and the HBD is no exception.

Using the Hip Bass Drum. Because there are so many variables, don't expect to hit on the hot sounds right away. Experiment! Generally, I would recommend not tuning the drum too low, keeping the resonance down, adding a fair amount of click, and going for a medium degree of "thud" (pulse width). For best results, when recording make your control

adjustments while listening to the bass drum coming directly off the tape (in other words, monitor the tape, not the input, while you are recording). Tape alters the character of the sound, and that must be taken into account for a good overall sound. Also, remember that many home studios are not constructed so as to allow for good bass response from the monitor speakers. So, make sure you aren't overloading the tape with lots of bass; this will come back and bite you later when you hear your tape on a good system (or try to get it mastered).

Other than the general guidelines given above, you're on your own. But whether you use the HBD by itself, or mixed in with digital drums, I think you'll be impressed with how much sound it delivers for a pretty minimal investment.

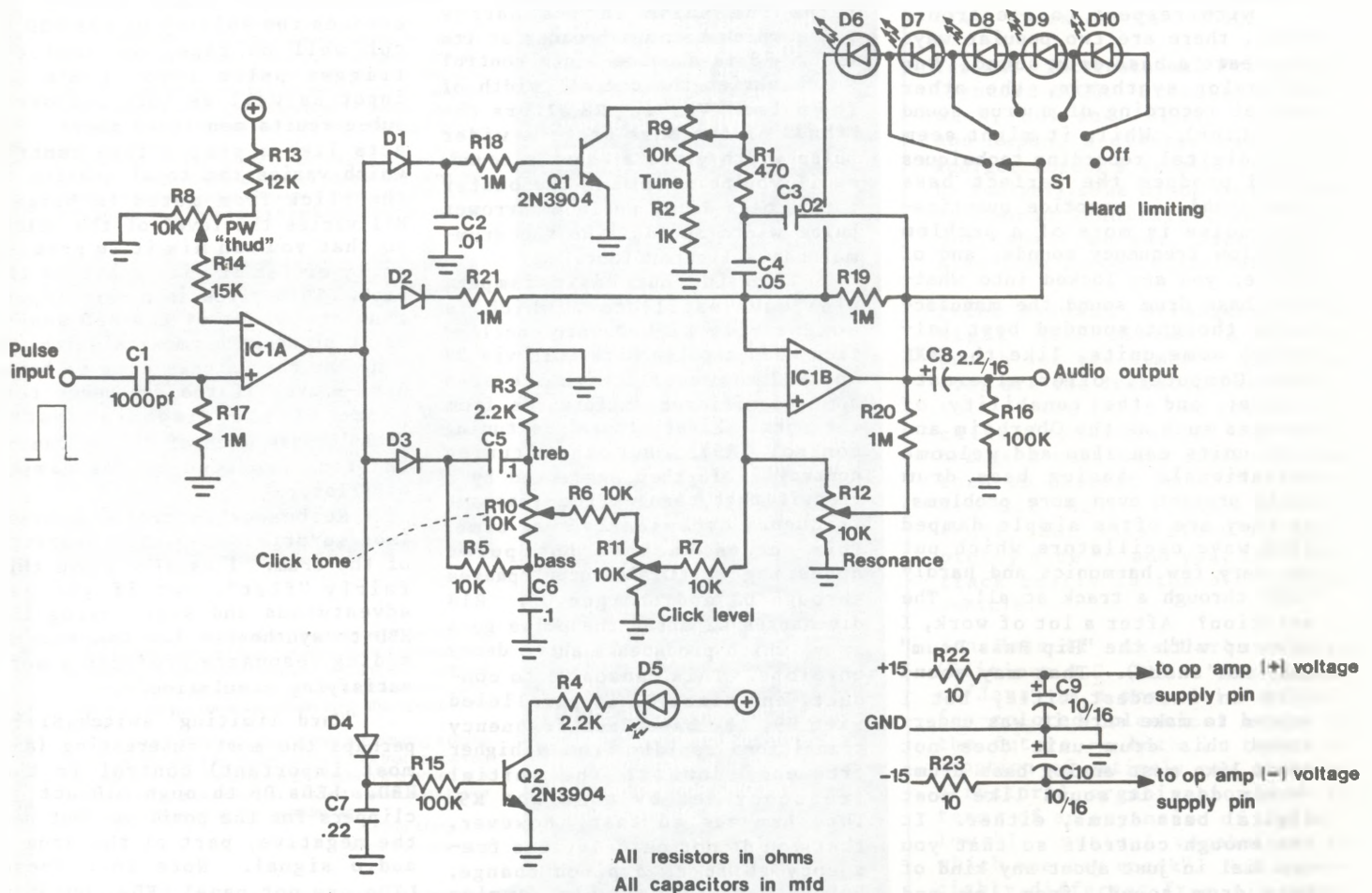

Parts list

Resistors (5% tolerance preferred)

R1	470 Ohms
R2	1k
R3, R4	2.2k
R5 - R7	10k
R8	10k linear taper pot (pulse width or "thud")
R9	10k linear taper pot (tuning)
R10	10k linear taper pot (click tone)
R11	10k linear or audio taper pot (click level)
R12	10k linear taper pot (resonance)
R13	12k
R14	15k
R15, R16	100k
R17 - R21	1M
R22, R23	10 Ohms

Capacitors (15 or more working Volts)

C1	1000 pF
C2	0.01 uF
C3	0.02 uF
C4	0.05 uF
C5, C6	0.1 uF
C7	0.22 uF
C8	2.2 uF
C9, C10	10 uF

Semiconductors

D1 - D4	1N914 or equivalent diodes
D5 - D10	Red LEDs
IC1	4739 (see text)

Mechanical parts

S1	SP6T rotary switch
Misc.	Sockets, circuit board, LED panel clip for D5, etc.

Note: A parts kit for the Hip Bass Drum, including all parts listed above, is available for \$19.95 from PGS Electronics (Route 25 - Box 304, Terre Haute, IN 47802). Add \$1.95 postage/handling, and \$1.75 extra for COD orders. Call the PGS 24 hour order line at 812/894-2839 to place VISA or Mastercard orders.

PolyTest:

the Hip Bass Drum

by Thomas Henry

(Editor's note: since I obviously was not going to do a Polytest on one of my own designs, I asked Thomas Henry -- the first person other than me to build the unit -- to write the Polytest. He submitted the following:)

After seeing this circuit, I eagerly built a prototype of the Hip Bass Drum to go with my computer controlled drum set (see related story in this issue -- Ed.). I say eagerly, since bass drum sounds had been giving me quite a bit of trouble, especially in the recording studio. All that has changed now! In one sentence, I can say quite honestly that the Hip Bass Drum is the most realistic sounding percussive instrument in my setup. It's equally easy to use for live or studio work, and surprisingly, was quite simple to build.

All of the controls basically work as you would expect them to. However, there are a couple of small points that should be mentioned. A quick look at the schematic shows that not many components make up this circuit; and there are always tradeoffs between low parts count and lack of interaction between the controls. One example of this concerns the click level and click tone pots. With the click level pot beyond half volume, the click tone pot ceases to have much effect. My solution to this is that I always try to keep the click level no higher than half way. Within this constraint, the click tone pot does a great job and really offers a broad range of "thuds", "pops", and "clicks".

Another fine point is that as the tuning control is raised, the resonance seems to increase as well. Thus, it takes longer for the drum sound to die out. Again, the solution is simple: turn down the resonance control to compensate.

Of course, these are tiny quibbles. Like all musical instruments, time must be spent learning the controls. I found it easy (and fun) to get familiar with the Hip Bass Drum. After only twenty minutes I was getting sounds unlike any I had gotten before; for the first time the bass drum really conveyed what a bass drum is supposed to convey! (Who says music is subjective?)

What's the bottom line, then? Simply, you will be hard pressed to find a more realistic bass drum anywhere. I genuinely feel that this circuit has no commercial equivalent. And if you're after a broad range of sounds, consider that the unit is very good at tom-tom sounds as well. Readers of *Polyphony* who are after the bizarre will also be relieved to know that a number of exotic sounds are available too; just play with those controls, and you'll find them.

I've saved the best endorsement for last. After building the Hip Bass Drum, I played an original recording exploiting it for Thomas Leonard, the drummer in my band. He said (and this is a quote), "I wish my bass drum sounded as good." That's quite a compliment coming from someone who has spent a lifetime playing acoustic drums!

Applied Synthesis:

Orchestral Voicings Using The Tenth Interval

By Bill Rhodes

The reason why symphonic music seems so full and lush is because of the many components which make up orchestration. These include the number of instruments, their varied timbres (tonal qualities), and how the personalities of individual performers influence the overall sound. However, one of the most important factors relating to orchestration is far more tangible than the other factors mentioned above, and can also be written out: voicing.

What is voicing? Voicing can make or break the sound of any orchestral or synthy-orchestral composition. Since in many cases we will be wanting to duplicate, by synthesis, traditional acoustic instruments, the same basic voicing concepts apply to both acoustic and electronic realizations.

How many times have you heard a string synthesizer that doesn't sound like strings at all, but like an old Emenee organ (or Harmonium)? The problem does not necessarily lie with the instrument, but rather, with the player's knowledge of chord construction and application. Indeed, with the correct knowledge of string synthesis (see Polyphony Nov/Dec 81) a more advanced string synth player can:

- Sustain single note lines over moving chords (legatures),
- Play chordally with deletions of harmonic members, or
- Block chord like crazy.

The latter is perhaps the most irritating of all string

<p>Ex.1</p> <p>C chord (10th in L.H.)</p>	<p>Ex.2</p> <p>C maj 7 (10th in L.H., tetrachord* in R.H.)</p>	<p>Ex.3</p> <p>C 7 (10th in L.H., tetrachord in R.H.)</p>
<p>Ex.4</p> <p>C 9 (10th in L.H., tetrachord in R.H.)</p>	<p>Ex.5</p> <p>C 11 (10th in L.H., tetrachord in R.H.)</p>	
<p>Ex.6</p> <p>C 13 (10th in L.H., tetrachord in R.H.)</p>	<p>Ex.7</p> <p>C 13 #11 (10th in L.H., tetrachord in R.H.)</p>	

synthesis textures since it sounds too much like an organist playing strings. Remember that when

string players play in ensemble, the music they create stretches over many octaves and inversions;

also, their integral intervallic relationships are very complex. Therefore, with simple block chording the voicings in both hands are too "closed" and don't create the illusion the player wants to create: namely, that of a symphonically tempered orchestra. Despite the fact that orchestral sounds are quite complex -- comprising a bass viol section, cello regiment, and a viola and violin subsection -- with proper voicing knowledge a lush, orchestrated sound can be duplicated in real-time with just our two hands and a good synthesizer.

Meet the Tenth. The interval of the 10th in the left hand (such as C to E -- see example 1) is extremely important in lending an orchestrated sound. I know some of you will complain about attempting this interval, because it may seem that the human hand just can't stretch that far. Granted, in certain instances where black and white keys are involved in less than proximal position, the stretch is difficult. But I guarantee you will be happy with the results when you make the effort to learn the various positions for this interval. (I have small hands for a keyboard player, but my ability to stretch from little finger to thumb has become increasingly better with practice. To increase your stretch you can buy hand grips from your local spa or sporting goods store, squeeze a tennis ball, or stretch your hands on a flat surface.)

Examples 2 through 15 show chords -- some altered, some polytonal, some jazzy -- using the 10th in the left hand (L.H.) or right hand (R.H.). When you apply these chord concepts to the synthesizer, you will notice a more orchestrated (and at times a modal/jazzy inflected) sound and feeling to your music. I have referenced all examples to the key of C to save paper and simplify sight reading, but make sure you practice transposing to all keys if you want to derive the most benefit from this technique. Finally, please do not think these concepts are restricted exclusively to string arranging; they also work great with horn, Rhodes, true synthy-sounds, and piano. Note that to use this interval with the piano you will need to develop strength as well as equal distribution of pressure of the fingers;

but these skills will help you get good results when working with any keyboard.

Next time, we'll cover more about the art and science of voicing...so stay tuned.

Ex.8	Ex.9

C chord (10th in L.H., 10th in R.H.)

C maj 7/G (10th in R.H. G in bass in L.H.)

Ex10	Ex11

C7 (10th in L.H., C7 in Root Position in R.H.)

C7/E (Wide Voicing R.H. & L.H.)

Ex12	Ex13

C maj 7 (10th in L.H., 9th stretch in R.H.)

C 11 (10th in L.H., 9th stretch in R.H.)

Ex14	Ex15

C 13 omit 7th & 9th (10th in L.H., IV maj 7 tetrachord in R.H.)

C 13# 11 (tetrachord 1 b7 in L.H., II# in R.H.)

The combinations are endless, try all keys, octaves, etc.

* Tetrachord: 4 note chord

Practical Circuitry

MICRO DRUMS

PART II

By: Tom Henry

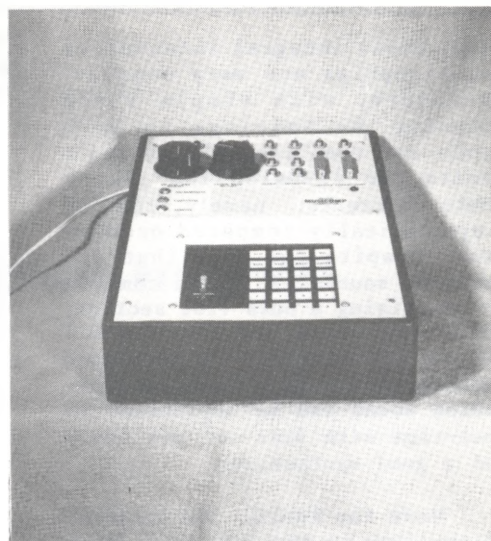

Last time in "Practical Circuitry" we discussed the hardware needed to implement Micro-Drums, a computer controlled drum unit. In this installment we will consider the software side of things. Since a lot needs to be said, let's jump right in and see how to punch up the program required to get Micro-Drums off and drumming!

Entering the program. Figure 1 shows the complete listing for Micro-Drums software. Since I used the PAIA 8700 computer, the code is written in 6502 assembly language. Those of you who plan to use Micro-Drums with some computer other than the PAIA unit will need to change the appropriate equates (at the start of the program) and may also need to alter the starting address. The source code in Figure 1 is heavily annotated, so you should be able to figure out how it works quite easily.

8700 users can ignore the line numbers, labels, mnemonics and comments if desired, since all that is needed to enter the program is the start address and the required code (under the heading "CODE", in the listing). Refer to your 8700 Computer/Controller manual for help in deciphering an assembler listing if you experience any difficulty.

Follow these steps to enter the program:

(1) Turn on the computer and hit the reset button.

(2) Load location \$ED with the byte \$1F. This sets the stack to a known condition needed by

Micro-Drums.

(3) Get ready to start loading data at \$0120, by punching in this address and hitting the DISP key.

(4) Using Figure 1 as a guide, start entering the data. The first few bytes are \$20, \$34, \$0F, A5, etc.

(5) Keep entering data until you hit the last byte in the listing. This is \$02 (at location \$028B). Use the PCH and PCL keys to confirm that you're at the right place.

(6) You're now ready to save the program to tape. Follow the normal 8700 Cassette Interface protocol for saving a program. The start address is \$1020, the end address is \$028B, and you can use \$01 for an identifier.

If all has gone well, you now have a working copy of the Micro-Drums program. After debugging your work (if needed), make a few backup copies as well. Now, let's see how to use the complete Micro-Drums system.

Using Micro-Drums. To use Micro-Drums, follow these instructions:

(1) Reset the 8700 computer.

(2) Load location \$ED with the byte \$1F. This sets the stack to a known condition needed by Micro-Drums. Do not forget this step; the program will not load or run correctly if it is left out!

(3) Using the standard loading procedure, load the Micro-Drums software. The start address is \$0120, the end address is \$028B and the identifier is \$01.

(4) Run the program by typing \$025F and hitting the RUN key. If everything has gone well, you will hear a long beep. This long beep indicates that you are in the main loop, and the computer is awaiting your instructions.

When in the main loop (as you now are), you have a choice of four commands. They are COARSE EDIT, FINE EDIT, TAPE and PLAY. After any of these commands have been executed, you will always be ushered back to the main loop. Even though the 8700 has limited display capabilities, you can always tell when you are back in the main loop by the long beep. Also, if you hit an invalid key when in the main loop, a long beep will occur. By listening for this beep, you can always tell what's happening at any moment.

Here follows a description of the four main commands. Note that when within the four main commands, there are other minor sub-commands possible.

FINE EDIT. The fine edit command defines measures of patterns which will be used as the basis for the entire song. You may define up to eight different patterns, each one up to 32 beats long. Or you may partition this in other ways; for example, four patterns of 64 beats each.

Each pattern is given a number-name. The numbers 0 through 7

are used for this purpose. To start editing a given pattern, when in the main loop type the number-name and then hit the PCL key. (Mnemonic: think of PCL as "low", for lowest level of editing, the pattern.) So to start editing pattern zero, type \$00 and then hit the PCL key.

You will now be sent from the main loop to the FINE EDIT routine. The display will show the current beat number, and the drum LEDs will show the drums to be played during that beat. To turn a drum on for the beat, touch one of the keys from 0 to 7. The corresponding LED will light up, and all of the currently selected drums will be played as a test. You can turn a drum off by touching the corresponding drum key again. Thus, the drum keys are like toggle switches and may be used to turn drums either on or off. There is one limitation, though: you may not have a particular beat play all eight drums at once. You can have up to seven drums playing at once, but not all of them. (The software uses the all-eight condition as an end-of-the-pattern marker.)

When you have achieved the selection of drums desired, touch the ENTER key. This will store the selection, then increment the beat pointer. The display will show the next beat number, and you are all set to enter the next selection. Also, when the display increments, the drums currently selected for the new beat will be triggered once. Thus you can single step through a pattern, for trial purposes, just by touching the ENTER key repeatedly. You can back step with the BACK key just as easily. And if you want to hear the current beat several times, touch the DISP key. This will sound the current drum selection.

As mentioned, keys 0 to 7 stand for drums 0 to 7. Key 8 stands for a rest. This clears out the drums selected for that beat. When you are done editing a pattern, touch the 9 key and you will be ushered back to the main loop. Note that even though the pattern may be up to 32 beats long, you are not obligated to use all of the beats. For example, with 5/4 time you might want to only use 10 beats.

COARSE EDIT. After creating some patterns (see above), you

```

00001 0000 ;*****
00002 0000 ;*
00003 0000 ;*          MICRO-DRUMS          *
00004 0000 ;*  MICROCOMPUTER CONTROLLED DRUM UNIT *
00005 0000 ;*
00006 0000 ;*          (C) 1983  THOMAS HENRY  *
00007 0000 ;*          VERSION 2.1  FEBRUARY 5, 1983 *
00008 0000 ;*
00009 0000 ;*****
00010 0000 ;
00011 0000 ;
00012 0000 ;IRQVEC = $00          ;IRQ VECTOR.
00013 0000 ;PATTER = $03        ;PATTERN POINTER BASE.
00014 0000 ;SELECT = $05        ;DRUM SELECT BIT PATTERNS.
00015 0000 ;PARAMS = $0D        ;TAPE PARAMETERS.
00016 0000 ;BEAT = $14          ;CURRENT BEAT POINTER.
00017 0000 ;SPOINT = $15       ;CURRENT EVENT SELECTED.
00018 0000 ;REPEAT = $16       ;CURRENT REPEAT COUNTER.
00019 0000 ;BUFFER = $F0       ;KEYBOARD BUFFER.
00020 0000 ;SCORE = $0280      ;DRUM SCORE AREA.
00021 0000 ;DISPLA = $0820    ;DISPLAY ADDRESS.
00022 0000 ;DRUMS = $08B0   ;DRUM OUTPUT ADDRESS.
00023 0000 ;RELAYS = $0E25  ;TURN ON TAPE RELAYS.
00024 0000 ;CASS = $0EAA    ;PERFORM CASSETTE OPERATION.
00025 0000 ;DECODE = $0F00  ;INPUT A BYTE.
00026 0000 ;GETKEY = $0F1F  ;GET A BYTE.
00027 0000 ;BEEP = $0F22   ;BEEP THE BEEPER.
00028 0000 ;LBEEP = $0F24  ;WITH SETUP, GIVES LONG BEEP.
00029 0000 ;SHIFT = $0F34   ;SHIFT BUFFER BY ONE DIGIT.
00030 0000 ;
00031 0000 ;
00032 0000 ;*** MAIN LOOP ***
00033 0000 ;
00034 0000 ;
00036 0000 ;          * = $0120
00037 0120 ;
00038 0120 20 34 OF ;NUMBER JSR SHIFT          ;SHIFT IN NEW DIGIT.
00039 0123 A5 F0     ;LDA BUFFER          ;FETCH PACKED ENTRY.
00040 0125 8D 20 08 ;STA DISPLA         ;THEN UPDATE THE DISPLAY.
00041 0128 4C 31 01 ;JMP INPUT          ;GO GET NEXT INPUT.
00042 012B A2 FF     ;MAIN  LDX #$FF       ;GET READY FOR LONG BEEP.
00043 012D 1B        ;CLC
00044 012E 20 24 OF ;JSR LBEEP          ;DO LONG BEEP.
00045 0131 20 1F OF ;INPUT JSR GETKEY     ;WAIT FOR KEYSTROKE.
00046 0134 C9 10     ;CMP #$10           ;IS IT A NUMBER?
00047 0136 90 EB     ;BCC NUMBER         ;YES, BRANCH BACK AND GET
00048 0138 C9 10     ;FIND  CMP #$10           ;IS IT 'PLAY'?
00049 013A F0 0F     ;BEQ PCMD
00050 013C C9 14     ;CMP #$14           ;IS IT 'COARSE'?
00051 013E F0 52     ;BEQ COARSE
00052 0140 C9 15     ;CMP #$15           ;IS IT 'FINE'?
00053 0142 F0 0A     ;BEQ FINE
00054 0144 C9 16     ;CMP #$16           ;IS IT 'TAPE'?
00055 0146 D0 E3     ;BNE MAIN           ;RAN OUT OF COMMANDS.
00056 0148 4C 37 02 ;JMP TAPE
00057 014B 4C E3 01 ;PCMD  JMP PLAY
00058 014E
00059 014E
00060 014E
00061 014E
00062 014E
00063 014E A5 F0     ;FINE  LDA BUFFER     ;GET PATTERN NUMBER.
00064 0150 20 57 02 ;JSR OFFSET        ;GET PATTERN OFFSET.
00065 0153 A0 00     ;LDY #$00          ;ZERO OUT THE BEAT POINTER.
00066 0155 C8
00067 0156 8B
00068 0157 8C 20 08 ;SHOWIT INY
00069 015A B1 03     ;BACKUP DEY
00070 015C 8D 80 08 ;STY DISPLA        ;DISPLAY IT.
00071 015F 20 4F 02 ;LDA (PATTER),Y   ;GET SELECTED BEAT,
00072 0162 C9 12     ;STA DRUMS         ;AND PLAY IT.
00073 0164 F0 F0     ;FEDIT JSR FEICH       ;GET EDIT KEYSTROKE.
00074 0166 C9 11     ;CMP #$12          ;IS IT A 'BACK'?
00075 0168 F0 EB     ;BEQ BACKUP        ;YES, BACKSPACE ONCE.
00076 016A C9 0A     ;CMP #$11          ;IS IT A 'DISP'?
00077 016C 90 0B     ;BEQ SHOWIT        ;YES, PLAY CURRENT BEAT.
00078 016E C9 13     ;CMP #$0A          ;IS IT A DRUM NUMBER (0-9)?
00079 0170 D0 ED     ;BCC DENTER        ;YES, GO ENTER DRUM BEAT.
00080 0172 C8        ;CMP #$13          ;IS IT AN 'ENTER'?
00081 0173 4C 55 01 ;BNE FEDIT         ;NO, RAN OUT OF COMMANDS.
00082 0176 C9 09     ;INY
00083 0178 D0 06     ;DENTER JMP SHOWIT      ;YES, ADVANCE TO NEXT BEAT.
00084 017A A9 FF     ;CMP #$09          ;#$09 MEANS END OF PATTERN.
00085 017C 91 03     ;BNE NEXT1
00086 017E D0 AB     ;LDA #$FF          ;END OF PATTERN MARKER.
00087 0180 C9 08     ;STA (PATTER),Y
00088 0182 D0 04     ;BNE MAIN
00089 0184 A9 00     ;NEXT1 CMP #$0B       ;BRANCH ALWAYS.
00090 0186 F0 05     ;BNE NEXT2        ;#$0B MEANS 'REST'
00091 0188 AA        ;LDA #$00
00092 0189 B5 05     ;NEXT2 TAX
00093 018B 51 03     ;LDA SELECT,X
00094 018D 91 03     ;EDR (PATTER),Y   ;INDEX INTO BIT PATTERN.
00095 018F 4C 55 01 ;STORE STA (PATTER),Y ;GET PROPER BIT PATTERN.
;AND SAVE IT.
;SOUND THE DRUM BEAT.

```

```

00096 0192      ;
00097 0192      ;
00098 0192      ;*** COARSE EDIT COMMAND ***
00099 0192      ;
00100 0192      ;
00101 0192 A6 F0 COARSE LDX BUFFER ;GET DESIRED EVENT NUMBER.
00102 0194 B4 15 STX SPOINT ;STORE AT CURRENT EVENT.
00103 0196 A6 15 REVEAL LDX SPOINT
00104 0198 BD 80 02 LDA SCORE,X ;GET CONTENTS OF EVENT.
00105 0198 B5 F0 STA BUFFER ;PUT IN BUFFER AND
00106 019D 8D 20 08 VIEW STA DISPLA ;SHOW IT TOO.
00107 01A0 20 1F 0F LOOP JSR GETKEY ;GET KEYSTROKE.
00108 01A3 C9 10 CMP #*10 ;CHECK FOR NUMBER.
00109 01A5 B0 08 BCS NONUM ;NOT A NUMBER, BRANCH.
00110 01A7 20 34 0F JSR SHIFT ;SHIFT IN NEW DIGIT.
00111 01AA A5 F0 LDA BUFFER ;FETCH PACKED ENTRY.
00112 01AC 4C 9D 01 JMP VIEW ;AND UPDATE DISPLAY.
00113 01AF C9 13 NONUM CMP #*13 ;IS IT AN 'ENTER'?
00114 01B1 D0 0C BNE NEXT3 ;NO, GO ON.
00115 01B3 A6 15 LDX SPOINT ;RE-GET EVENT NUMBER.
00116 01B5 A5 F0 LDA BUFFER ;FETCH INPUT NUMBER.
00117 01B7 9D 80 02 STA SCORE,X ;STORE IN SCORE.
00118 01BA E6 15 INC SPOINT ;UPDATE EVENT NUMBER.
00119 01BC 4C 96 01 JMP REVEAL ;UPDATE DISPLAY.
00120 01BF C9 12 NEXT3 CMP #*12 ;IS IT A BACKSPACE?
00121 01C1 D0 05 BNE NEXT4 ;NO, BRANCH ON.
00122 01C3 C6 15 DEC SPOINT ;DECREMENT EVENT COUNTER.
00123 01C5 4C 96 01 JMP REVEAL ;SHOW CONTENTS OF EVENT.
00124 01C8 C9 14 NEXT4 CMP #*14 ;IS IT A 'PCH'?
00125 01CA D0 05 BNE NEXT5 ;NO, BRANCH ON.
00126 01CC A5 15 LDA SPOINT ;GET CURRENT EVENT NUMBER.
00127 01CE 4C 9D 01 JMP VIEW ;AND SHOW IT.
00128 01D1 C9 11 NEXT5 CMP #*11 ;IS IT A 'DISP'?
00129 01D3 F0 C1 BEQ REVEAL ;IF SO, SHOW CONTENTS.
00130 01D5 C9 17 CMP #*17 ;'REL' STANDS FOR ALL DONE.
00131 01D7 D0 C7 BNE LOOP ;RAN OUT OF COMMANDS.
00132 01D9 A6 15 LDX SPOINT ;RE-GET EVENT NUMBER.
00133 01DB A9 00 LDA #*00 ;END OF SCORE MARKER.
00134 01DD 9D 80 02 STA SCORE,X
00135 01E0 4C 2B 01 JMP MAIN ;RETURN TO MAIN LOOP.
00136 01E3      ;
00137 01E3      ;
00138 01E3      ;*** 'PLAY' COMMAND ENTRY ***
00139 01E3      ;
00140 01E3      ;
00141 01E3 A9 00 PLAY LDA #*00 ;ZERO OUT REPEAT AND
00142 01E5 85 16 STA REPEAT ;SCORE POINTER.
00143 01E7 A9 FF LDA #*FF
00144 01E9 85 15 STA SPOINT
00145 01EB 58 CLI ;PREPARE FOR IRQ.
00146 01EC C9 FF TIGHT CMP #*FF ;*FF MEANS KEEP PLAYING.
00147 01EE F0 FC BEQ TIGHT ;STAY IN TIGHT LOOP.
00148 01F0 4C 2B 01 JMP MAIN ;ABORT 'PLAY' NOW.
00149 01F3      ;
00150 01F3      ;
00151 01F3 20 00 0F IRQRTN JSR DECODE ;SEE IF ZERO KEY IS PUSHED.
00152 01F6 C9 00 CMP #*00
00153 01FB D0 04 BNE PLAMDR ;IT ISN'T, SO PLAY MORE.
00154 01FA 28 FINISH PLP ;SET INTERRUPT FLAG
00155 01FB 78 SEI ;SO NO MORE OCCUR.
00156 01FC 08 PHP
00157 01FD 40 RETURN RTI
00158 01FE      ;
00159 01FE      ;
00160 01FE A5 14 PLAMDR LDA REPEAT ;REPEATED OLD PATTERN ENOUGH?
00161 0200 D0 19 BNE MORE ;NO, KEEP GOING WITH OLD ONE.
00162 0202 E6 15 INC SPOINT ;YES, UPDATE SCORE POINTER.
00163 0204 A6 15 LDX SPOINT
00164 0206 BD 80 02 LDA SCORE,X ;GET REPEAT TIME DATA.
00165 0209 F0 EF BEQ FINISH ;DONE PLAYING WHOLE SCORE.
00166 0208 B5 16 STA REPEAT ;CONTAINS NUMBER OF REPEATS.
00167 020D E6 15 INC SPOINT ;UPDATE SCORE POINTER.
00168 020F A6 15 LDX SPOINT
00169 0211 BD 80 02 LDA SCORE,X ;GET PATTERN NAME DATA.
00170 0214 20 57 02 JSR OFFSET ;GET PATTERN ADDRESS OFFSET.
00171 0217 A9 00 LDA #*00
00172 0219 B5 14 STA BEAT ;ZERO OUT BEAT POINTER.
00173 021B A4 14 MORE LDY BEAT ;Y INDEXES TO PROPER BEAT.
00174 021D B1 03 LDA (PATTER),Y ;GET OUTPUT DATA.
00175 021F C9 FF CMP #*FF ;END OF PATTERN?
00176 0221 D0 08 BNE OKAY ;NO, GO PLAY THE BEAT.
00177 0223 C6 16 DEC REPEAT ;DECREMENT REPEAT TIME.
00178 0225 A9 00 LDA #*00 ;YES, RESET BEAT COUNTER.
00179 0227 B5 14 STA BEAT ;THEN TRY AGAIN.
00180 0229 F0 C8 BEQ IRQRTN ;BRANCH ALWAYS.
00181 022B 8D 80 08 OKAY STA DRUMS
00182 022E 8C 20 08 STY DISPLA
00183 0231 E6 14 INC BEAT ;UPDATE BEAT POINTER.
00184 0233 A9 FF LDA #*FF
00185 0235 D0 C6 BNE RETURN ;BRANCH ALWAYS.
00186 0237      ;
00187 0237      ;
00188 0237      ; *** 'LOAD' AND 'SAVE' COMMAND ***
00189 0237      ;

```

will then string them together in various arrangements to form the complete song. This is COARSE editing. You will create a score by entering some events; each event consists of two entries. The first entry is the number of times you wish a pattern to repeat, and the second entry is the number-name of the pattern which is to be repeated. There is room for 64 events total. This will allow songs up to fifteen minutes long to be programmed! To get into the COARSE EDIT mode from the main loop, type the number of the event you wish to start at (usually a \$00) and then the PCH key. (Mnemonic: think of PCH as "high", the highest level of editing.)

The display will now show the contents of the current event. To enter a new event, type the desired number and hit the ENTER key. The event will be recorded, and the score pointer is incremented once. For example, starting at event zero, to get sixteen repeats of one, type \$10, ENTER, \$01, ENTER. Note that all numbers are in hexadecimal and that each entry must be followed by an ENTER.

You can backspace through a score with the BACK key. Also, to see the current event number, touch the PCH key at any time. To see the contents of the event, type DISP. Using the keys just mentioned, you can step through an entire score in a matter of minutes and change or update it as needed.

To finish off a score, touch the REL key. This puts in an end of score marker and returns you to the main loop. A long beep will occur.

PLAY. Playing a score is easy. First make sure that the SYNC INPUT jack has some source of triggers. You may sync the drum score off of the internal variable clock, an external clock, keyboard triggers, sequencer triggers, or click tracks from a tape deck. The input pulses should be +5V in magnitude. Note that Micro-Drums' internal variable clock meets this need and is perhaps the easiest to use. In addition it allows easy adjustment of the tempo: just dial in the desired speed. This may not seem like much, but consider what we've just done: a potentiometer controls the tempo, continuously, without the intervention of an analog to digital con-

verter. How's that for saving money and keeping things simple!

After providing some source of sync pulses, you may start playing the score simply by touching the RUN key. When the song is finished, you will be sent back to the main loop and a long beep will occur. You can also abort a song while it is playing by touching the 0 key. Once again, you will return to the main loop.

As you can see, the SYNC INPUT (alias the IRQ) is the key to the power of Micro-Drums. Any circuit which can put out a series of pulses can cause Micro-Drums to step through the song, beat after beat. You are not constrained to meet this or that condition, and the circuitry is perfectly general. Simply send the computer some pulses and the song commences! And don't forget the SYNC OUTPUT jack either. You can cause some other circuit (like a sequencer) to follow Micro-Drums just as easily, so Micro-Drums can thus play the role of master or slave with equal ease.

TAPE. You can save or load scores using this command. To save a score, start the recorder going in the record mode, type \$DD and touch the TAPE key. The computer will do the rest; there is no need to enter any addresses, etc.

Loading a score is just as easy. Start the recorder going in the play mode, type \$11 and hit the TAPE key. The score will be loaded.

At the end of any tape operation you will be sent back to the main loop, and a long beep will indicate this fact. Note that the load and save options affect the entire score and pattern memory, so don't be alarmed if the operation takes up to a minute or so. If you experience any trouble, refer to the 8700 Cassette Interface manual and review how to set volume levels and so on.

The future. Well, that just about wraps up how to use Micro-Drums. Of course, all we have done here is talk about the mechanics of using the unit; it's up to you to think about the musical side of things. For example, if you know that a particular pattern is to contain both eighth notes and triplets, then you will need to divide the pattern into groups of twenty-four (three times

```

00190 0237 ;
00191 0237 A2 07 TAPE LDX ##07 ;PREPARE TAPE PARAMETERS.
00192 0239 B5 0C SETFIL LDA PARAMS-1,X ;GET PARAMETERS.
00193 023B 95 F0 STA BUFFER,X ;AND STUFF IN PLACE.
00194 023D CA DEX
00195 023E D0 F9 BNE SETFIL ;KEEP STUFFING IF NEEDED.
00196 0240 A5 F0 LDA BUFFER ;GET LOAD/SAVE TOKEN.
00197 0242 20 25 0E JSR RELAYS ;TURN ON RELAYS.
00198 0245 20 AA 0E JSR CASS ;PERFORM LOAD OR SAVE.
00199 0248 18 CLC
00200 0249 20 22 0F JSR BEEP ;TURN OFF RELAYS AND BEEP.
00201 024C 4C 2B 01 JMP MAIN ;ALL DONE!
00202 024F ;
00203 024F ;
00204 024F 84 14 FETCH STY BEAT ;GET A KEY, BUT SAVE
00205 0251 20 1F 0F JSR GETKEY ;CURRENT Y-REGISTER.
00206 0254 A4 14 LDY BEAT
00207 0256 60 RTS
00208 0257 ;
00209 0257 ;
00210 0257 0A OFFSET ASL A ;FIND OFFSET BY
00211 0258 0A ASL A ;MULTIPLYING ACCUMULATOR
00212 0259 0A ASL A ;BY SIXTEEN.
00213 025A 0A ASL A
00214 025B 0A ASL A
00215 025C 85 03 STA PATTERN ;OFFSET ADDRESS IS HERE.
00216 025E 60 RTS
00217 025F ;
00218 025F ;
00219 025F ;*** INITIALIZATION ROUTINE ***
00220 025F ;
00221 025F ;
00222 025F 78 SEI
00223 0260 A2 00 LDX ##00
00224 0262 BD 7B 02 MOVE LDA DATA,X ;GET DATA BYTE.
00225 0265 95 00 STA IRQVEC,X ;STUFF IT INTO 0-PAGE.
00226 0267 EB INX
00227 0268 E0 14 CPX ##14 ;NUMBER OF BYTES+1.
00228 026A D0 F6 BNE MOVE
00229 026C A0 00 LDY ##00 ;CLEAR PATTERN AREA.
00230 026E A9 00 LDA ##00
00231 0270 91 03 CLEAR STA (PATTERN),Y
00232 0272 88 DEY
00233 0273 D0 FB BNE CLEAR
00234 0275 4C 2B 01 JMP MAIN ;GO START UP MICRO-DRUMS.
00235 0278 ;
00236 0278 ;
00237 0278 ;*** DATA AND ADDRESS TABLES ***
00238 0278 ;
00239 0278 ;
00240 0278 4C DATA .BYTE #4C ;OPCODE FOR 'JMP'.
00241 0279 F3 01 .WORD IRQRTN ;START OF IRQ ROUTINE.
00242 027B 00 03 .WORD #0300 ;PATTERN BASE ADDRESS.
00243 027D 01 .BYTE #01, #02 ;DRUM SELECT BIT PATTERNS.
00244 027E 02 .BYTE #04, #08
00244 027F 04 .BYTE #10, #20
00244 0280 08 .BYTE #40, #80
00245 0281 10 .BYTE #00 ;FILE PARAMETER.
00245 0282 20 .WORD #03FF ;TAPE END ADDRESS.
00246 0283 40 .WORD #0280 ;TAPE START ADDRESS.
00246 0284 80 .WORD #0280 ;TAPE POINTER.
00247 0285 00 .END
00248 0286 FF 03
00249 0288 80 02
00250 028A 80 02
00251 028C

ERRORS = 00000
END OF ASSEMBLY

```

eight). This is just one example of one of the musical considerations that must be taken into account with Micro-Drums. However, you will find that the more you play with Micro-Drums, the better you will become at visualizing what needs to be done.

Well, we've run out of room and need to start planning other projects. But in the meanwhile, as you play with the unit, think about how you would implement

sequencer interfaces with Micro-Drums. The procedure is actually quite simple due to the "magical" way in which the SYNC INPUT works. Then consider synchro-sonic recording; how would you do this with Micro-Drums? Once again, the basic principle is quite simple. Think about these things and perhaps later on in the pages of "Practical Circuitry" we can compare notes.

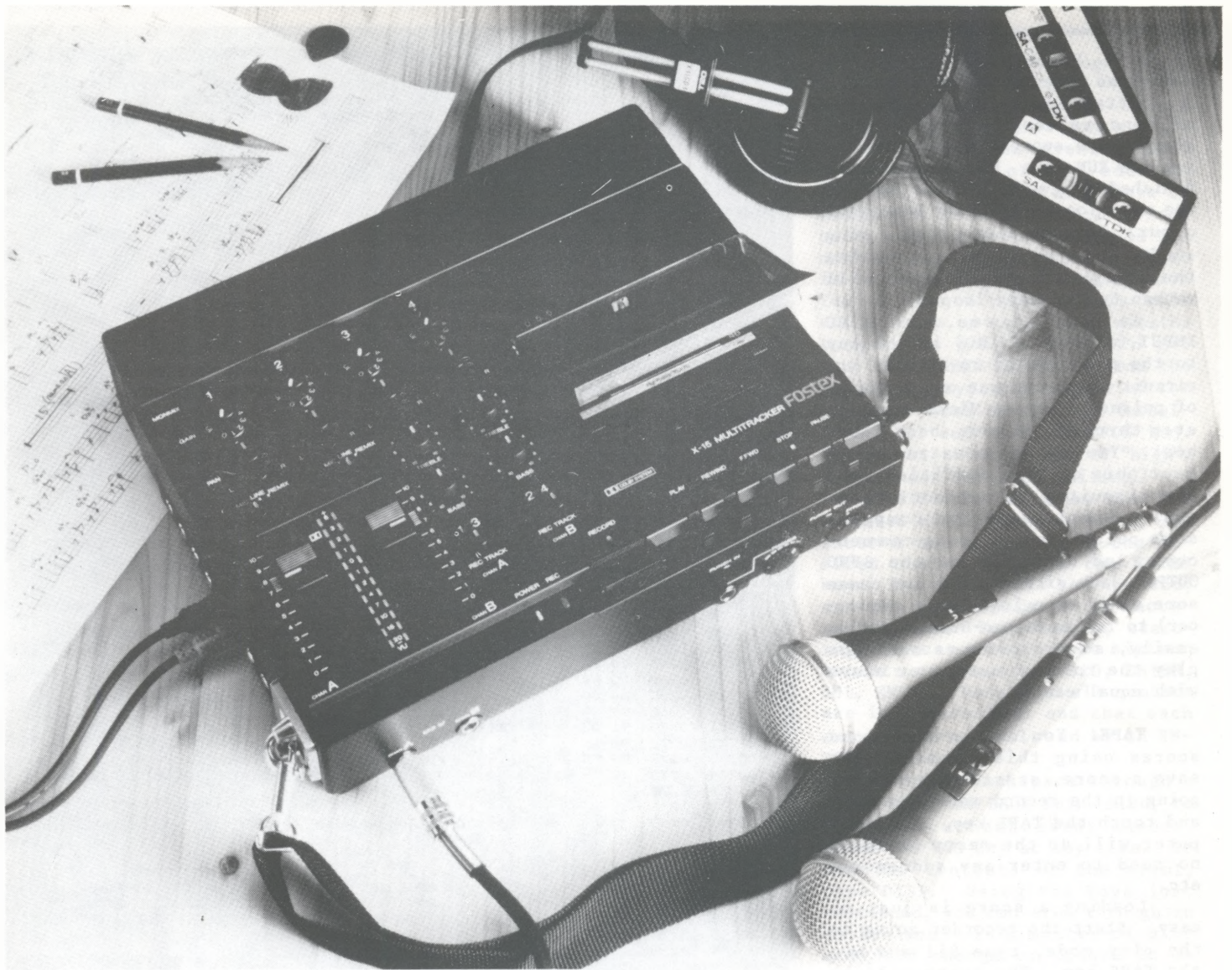

FOSTEX X-15 REVIEWED

By: Tom Mulhern

For years, TEAC has dominated the consumer 4-track tape recorder market; most of the reel-to-reel (or multitrack cassette) machines installed in home studios have a TEAC or TASCAM nameplate. But this summer, Fostex -- one of the newcomers to multitrack manufacturing -- introduced the X-15, a "personal" sized 4-channel cassette-based recorder. It's small (7 1/2" x 11" x 2 3/4"), light (the X-15 itself weighs 4 lbs. 9 oz.; adding the 10 C cell battery pack increases the weight to 6 lbs. 3 oz.), easy-to-use, and inexpensive (\$495.00 list price). For field use, the X-15 includes an easily-removed, heavy-duty nylon strap at no extra cost; optional

punch-in and punch-out "footswitches" (more on these later) cost \$12.00 each. Considering the high price of batteries today, the optional \$30.00 AC adapter is highly recommended. Also, take the cost of good tape into the cost of playing with the X-15, since Fostex suggests using high-bias tape in order to optimize performance.

Naturally, there are certain limitations due to the X-15's diminutive size and low price. The power switch is located on the battery pack; there's also an on/off switch on the AC adapter. Unusual locations, but no major obstacles. Also, the transport mechanism has only one speed: 1 7/8 ips (standard cassette speed). But the main limitation of the

unit is that only two tracks of the four tracks can be recorded on simultaneously. In other words, you can record on one pair of tracks, and then the second pair of tracks, but not all four tracks at once. Those wishing to record, say, a band in a live situation and expecting to place each instrument on its own track will not be able to do so with the X-15. It's intended primarily as a tool for creating demos, and it serves as a very good aid to songwriters who want to make more music than two hands and one voice will allow at one time.

So much for the basic philosophy behind the X-15's design, now for the features. The right half of the top panel contains the tape recorder. There is a 3-digit mechanical counter with a reset button, and a clear, orange door protects the tape compartment from dust. A green LED and a red LED indicate "power on" and "record on" modes, respectively. The X-15 has Dolby B noise reduction, which, incidentally, is always engaged and cannot be turned off. However, this type of noise reduction works well and because it can't be deactivated, you can't, for instance, inadvertently encode three tracks then forget to encode the last one. The Dolby B circuitry makes for more consistent recordings, and contributes to surprisingly low noise operation.

The recorder section's controls, from left to right, are Record, Play, Rewind, Fast Forward, Stop, and Pause. The Record control can be activated while the machine is in "play" mode. This is great, because you can punch in a solo or a passage by pressing just one button. The Record button is conveniently about an inch wide; I found it easy to leave the recorder sitting on the floor while I listened to a playback, and when the spot came for adding a solo, I simply pressed Record with my big toe. Crude but effective! For the more cultured, or those who insist on wearing shoes during home taping sessions, there are optional punch-in and punch-out switches. These connect to the front of the X-15 through two ports (these "switches" aren't really switches at all; they're actually rubber bulbs with cables that connect to plungers at the other end -- much like the remote squeeze mechanisms for use with 35mm cameras). Unfortunately, though, if the Play switch isn't engaged, and you depress the Record button, both the Record and Play buttons are switched on. Thus, while setting levels you must have the Pause switch on, but this means that the motor is running while you're setting your tones and levels.

A stereo headphone jack, with accompanying volume control, is located near the punch-in and punch-out ports. Next is a pitch control, which allows you to alter the recorder's speed +15% in order to match the tuning of previous recordings to new overdubs. So, if you have recorded a bunch of overdubs and then suddenly find that your piano is tuned sharp or flat compared to your original tuning reference, no sweat.

A sneaky but useful application of the variable speed control involves lengthening echoes beyond your delay unit's normal range. Want a longer echo? Just record a track at normal speed, play it back through your echo device with the pitch adjustment increased, then record the results on to another channel. When you return the pitch control to its neutral position and play back the newly recorded channel, the echoes will be much longer in duration.

The X-15's tracks can be sent to two basic channels: A and B. Each has a selector switch for

mic/line/remix, slide-pot input level control (with a 2 3/4" travel and adjacent LED ladder calibrated from -20dB to +6dB), treble control (+12dB at 10 kHz), and bass control (+12dB at 100 Hz). Channel A has a selector for tracks 1 and 3; channel B has a selector for tracks 2 and 4. Placing either switch in its middle position puts it in a "safety" mode, which prevents accidental record-overs. Two 1/4" mic inputs (labelled Chan A and Chan B) are located on the front of the X-15, while RCA-type line inputs and line outputs are located on the side -- right next to the four separate tape outputs.

The monitoring and mixing section, logically labelled Monmix, has a gain pot and pan pot for each of the four channels. The gain knobs have 0-10 printed on them, while the pan pots have a 0 point and go +10 units. This is helpful for recalling mixes when you're making a 2-track master of several songs. The gain and pan controls allow you to monitor any or all previous tracks when overdubbing, and you can do a rough mix into your headphones -- great for getting a feel for the final product while you're recording.

By using the mic/line/remix selector, the pan pots, and track selectors, you can combine two tracks onto a third. The process is complicated to explain, but fairly easy to do. The book that comes with the X-15 has good graphics and text to guide you. However, I crave stereo imaging, and when two channels are mixed to one, you do get a mix but it is a mono mix. I found that I could retain my stereo separation by mixing all four channels via the gain and pan pots, and sending the stereo mix into a standard cassette deck. I could then take the 2-channel mixdown cassette from the standard deck and place it in the Fostex, thereby giving me a good stereo mix on channels 1 and 2 and leaving channels 3 and 4 open for more dubs. (Note: If you use stereo effects devices that employ 180 degree out-of-phase outputs, it's a good idea to not put their outputs on adjacent tracks, since any bleed from one track to an adjacent track might cause cancellation. (I didn't experience this problem, however.)

Regardless of how you overdub and mix, you can't keep adding material upon material forever -- any analog recording machine has that limitation. However, I found that I could ping-pong at least twice before getting horrendous degradation, and by careful planning (a must for any recorder with less than 10,000 tracks) and using restraint (you don't really need 63 guitars on that song, do you?), it was easy to turn out a relatively quiet, nicely EQ'd demo.

I can only think of a couple of places where Fostex might improve the X-15. First, it would be a very useful feature to have at least two headphone outputs. Second, making the Record and Play buttons independent so that the motor wouldn't get so much wear and tear between takes would also be a sensible alteration. Finally, I also found that by going back over one section over and over, the tape tightened too much, causing it to stop dead in its tracks a few times. A word to the wise: Rewind and fast-forward the tape every few minutes if you are going to be punching in a lot of little parts.

Like many people who will likely be purchasing an X-15, this is my first multitrack recorder, and I wouldn't part with it for anything. It affords freedom and versatility, and best of all, it doesn't break your bank account.

BASIC FILM SCORING MATH

By: Dr. Maury Deutsch

Scoring films is a highly exacting art; the free timing of a musical segment requires a knowledge of both tempo and duration. To allow for a proper correlation between music and video, timing cues placed in appropriate measures of a score allow the conductor to keep check with a stop watch and anticipate cues relating to specific dialogue or changes of locale.

Formulas for time duration/tempo/total measures. The following formulas enable composers to determine the number of measures, time duration, or metronomic speed of a sequence when two of the three quantities are known. Ritardando, fermato, and accelerando (changes in tempo) need to be written out exactly or considered separately.

$$(a) (60 TM) / S = Ts / B$$

$$(b) TM / S = Tm / B$$

$$(c) TM / (60 S) = Th / B$$

T = total
S = metronomic speed
B = beats in a measure
M = measures
s = seconds
m = minutes
h = hours

Example: The elapsed time of a particular sequence is 30 and 2/3 (30 2/3) seconds. How many measures are needed in 3/4 time if the metronomic speed is 90 beats per minute?

Formula (a) is most suited to solving this problem:

$$(60 TM) / 90 = (30 \frac{2}{3}) / 3$$

$$TM = 15 \frac{1}{3}$$

The answer is 15 1/3 measures in 3/4 time, or 15 measures and 1 beat.

Very often the time signature will vary during a sequence, e.g., 3/4 to 12/8 to 5/4, etc. Slight modifications of the above equations will accommodate this change.

$$(a) (60 Tb) / S = Ts$$

$$(b) Tb / S = Tm$$

$$(c) Tb / (60 S) = Th$$

T = total
S = metronomic speed
b = beats
s = seconds
m = minutes
h = hours

If once again the elapsed time was 30 2/3 seconds, the total number of beats would be 46:

$$(60 Tb) / 90 = 30 \frac{2}{3}$$

$$Tb = 46$$

These 46 beats could be grouped in a variety of meters, as shown in figure 1. This elemental sketch is the basis for eventual orchestration.

Click Track formulas. A click track is necessary for exact synchronization of music and action. Although 35 mm. is the usual standard, it is not the only size of film available. All sizes of film are projected at 24 frames per second; however, the number of frames per foot varies. To determine projection time, divide the frames per foot by 24. (Also see the section "Correspondences".)

A metronomic marking can be translated to a click track and vice versa.

$$(a) (24/C.T.) 60 = S \text{ or } 1440 / C.T. = S$$

$$(b) (60/S) 24 = C.T. \text{ or } 1440 / S = C.T.$$

S = Metronomic tempo
C.T. = Click Track

Example: What click track is equivalent to a metronomic marking of 100?

$$(60/100) X 24 = C.T.; 14 \frac{2}{5} = \text{fr. C.T.}$$

The answer is a 14 2/5 frame click track.

Example: What metronomic speed is equivalent to a 24 3/4 frame click track?

$$(24 / (24 \frac{3}{4})) X 60 = S; 58 \frac{2}{11} = S$$

The approximate answer is a metronomic speed of 58+ beats per minute.

Click track subdivisions. Click tracks are the result of perforations introduced into the sound film track. The clicks are frequently transmitted to the conductor and musicians through single headphones. A click track can be subdivided into eighths:

- 16 fr. C.T.
- 16 1/8 = 16.125 = 16-1 fr. C.T.
- 16 2/8 = 16.25 = 16-2 " "
- 16 3/8 = 16.375 = 16-3 " "
- 16 4/8 = 16.50 = 16-4 " "
- 16 5/8 = 16.625 = 16-5 " "
- 16 6/8 = 16.75 = 16-6 " "
- 16 7/8 = 16.875 = 16-7 " "
- 17 fr. C.T.

Example: A 14 2/5 fr. C.T. would of necessity be notated as a 14-3 fr. C.T. (with the "-3" representing the 3rd eighth note of the measure).

Time duration/click track/total measures/total beats. Following are the most useful formulas correlating the above quantities:

- (a) $(C.T.)(TM) / 24 = Ts/B$
- (a') $(C.T.)(Tb) / 24 = Ts$
- (b) $(C.T.)(TM) / 24 = (60 TM) / B$
- (b') $(C.T.)(Tb) / 24 = Tm$
- (c) $(C.T.)(TM) / 24 = (60)2 Th / B$
- (c') $(C.T.)(Tb) / 24 = (60) Th$

C.T. = click track

T = Total

M = measures

B = beats in a measure

b = beats

s = seconds

m = minutes

h = hours

Example: Find the duration of 32 measures in 4/4 if the frame-click beat is 18-3.

$$(18 \frac{3}{8})(32) / 24 = Ts/4; Ts = 98$$

$$(18 \frac{3}{8})(32) / 24 = (60 Tm) / 4; Tm = 1 \frac{19}{30};$$

$$(19/30 = 38) Tm = 1 \text{ minute } 38 \text{ seconds.}$$

Example: Find the duration of 64 beats if the frame-click beat is 14-2.

$$(14 \frac{2}{8})(64) / 24 = Ts; Ts = 38 \text{ seconds.}$$

Footage versus timing. Footage can be translated into timing and vice versa.

$$Tf = 3/2 Ts$$

$$Ts = 2/3 Tf$$

T = Total

f = feet

s = seconds

Example: 126 feet of film is equivalent to how many seconds? →

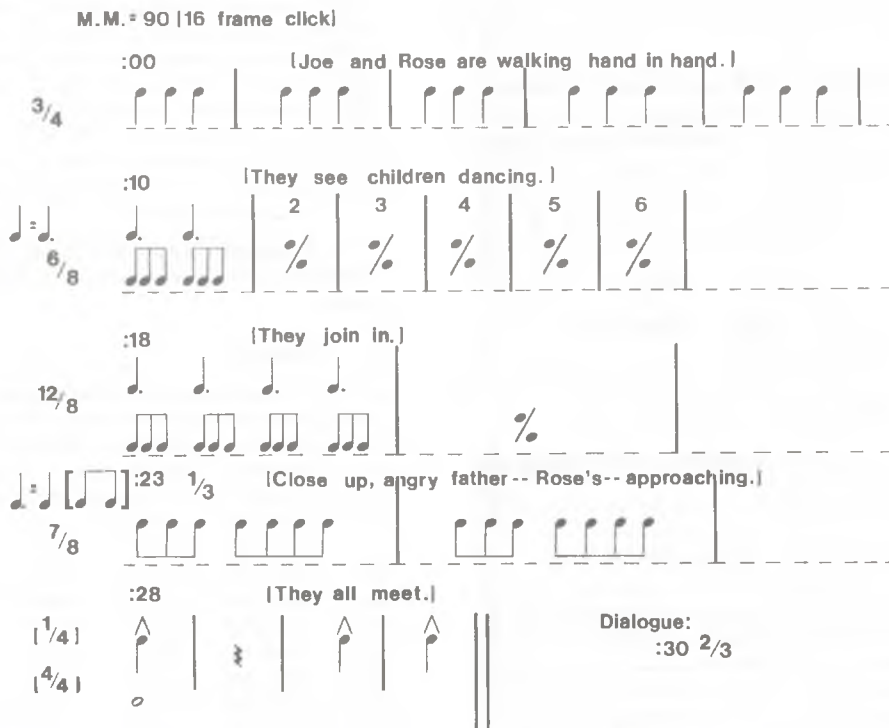

figure 1

$T_s = 2/3 \times 126 = 84$ seconds (or 1' 24").

Example: 2 minutes 54 seconds of film is equivalent to how much footage?

$T_f = 3/2 \times 174 = 261$ ft.

When scoring to footage, the timing cues are multiples of 2/3 (film runs at 1 ft. per 2/3 sec.)

Table of Correspondences. The following table relates film size, frames per ft., projection time, and ft./minute:

Film Size (mm)	Frames/Ft.	Projection time	Ft./min.
35	16	2/3 sec. (16/24)	90
70	8	1/3 sec. (8/24)	180
16	40	1 2/3 sec. (40/24)	36
8	80	3 1/3 sec. (80/24)	18
Super 8	72	3 sec. (72/24)	20
17 1/2	32	1 1/3 sec. (32/24)	45

Determination of a specific click track. At times, it may be necessary to determine a specific click track (where the time duration and number of beats are known) in order to reach an exact attack point.

Example: Determine the click track needed to meet a musical cue at 15 seconds, beat 17. The attack on the 17th beat occurs after 16 beats have been completed. The net result is to subtract one for the total number of beats; in this example, $T_b = 16$. $(C.T.)(T_b) / 24 = T_s$ can be written as $C.T. = (24 T_s) / T_b$. $C.T. = (24 \times 15) / 16 = 22 \frac{1}{2}$ (22-4). The 22-4 click track will enable the composer to meet a picture obligation exactly at 15 seconds on beat 17.

Click track charts. Click track charts are commercially available for the film and television composer; however, they can be worked out as needed. Review equation: $(C.T.)(T_b) / 24 = T_s$

C.T. = click track

T = total

b = beats

s = seconds

T_b is equal to the "beat number" minus one

Examples:

(1) C.T. = 11-2 (Metronomic speed = 128)

Frame Number	Beat Number	Seconds
0	1	.00
11-2	2	.47
22-4	3	.94
33-6	4	1.41
45 (44-8)	5	1.87
56-2	6	2.34
67-4	7	2.81
78-6	8	3.28
90 (89-8)	9	3.75
101-2	10	4.22
etc.	etc.	etc.

(2) C.T. = 9-1 (Metronomic speed = 157.81)

Frame Number	Beat Number	Seconds
0	1	.00
9-1	2	.38
18-2	3	.76
27-3	4	1.14
36-4	5	1.52
45-5	6	1.90
54-6	7	2.28
63-7	8	2.66
73	9	3.04
82-1	10	3.42
etc.	etc.	etc.

(3) C.T. = 12 (Metronomic speed = 120)

Frame Number	Beat Number	Seconds
0	1	.00
12	2	.50
24	3	1.00
36	4	1.50
48	5	2.00
60	6	2.50
72	7	3.00
84	8	3.50
96	9	4.00
108	10	4.50
etc.	etc.	etc.

(4) C.T. = 14-3 (Metronomic speed = 100.17)

Frame Number	Beat Number	Seconds
0	1	.00
14-3	2	.60
28-6	3	1.20
43-1	4	1.80
57-4	5	2.40
71-7	6	2.99
86-2	7	3.59
100-5	8	4.19
115	9	4.79
129-3	10	5.39
etc.	etc.	etc.

A second type of duration chart relates click tracks with a variety of phrase and period groupings.

Example:

Four Measures (Duration time in seconds)

C.T.	Metro speed	Duple meter	Triple	Quadruple	Quintuple
9	160.00	3.00	4.50	6.00	7.50
9-1	157.81	3.04	4.56	6.08	7.60
9-2	155.68	3.08	4.62	6.17	7.71
9-3	153.60	3.12	4.68	6.25	7.81
9-4	151.58	3.17	4.74	6.33	7.92
9-5	149.61	3.20	4.80	6.42	8.02
9-6	147.69	3.25	4.87	6.50	8.13
9-7	145.82	3.29	4.93	6.58	8.23
10	144.00	3.33	5.00	6.67	8.33
10-1	142.22	3.38	5.06	6.75	8.44

FIG. 2

(1) $\frac{4}{4}$ 12-4 | | | 12-5 12-6 12-7 13 | 13-1 13-2 13-3 13-4 |
 $\frac{3}{4}$ 13-5 13-6 13-7 | 14 | etc.

(2) $\frac{4}{4}$ 12-4 | | | 12-5 12-6 | 12-7 12-8 13 | 13-1 13-2 |
 $\frac{4}{4}$ 13-3 13-4 | 13-5 13-6 | 13-7 14 | etc.

(3) $\frac{4}{4}$ 12-4 | | | 12-5 | 12-6 | 12-7 | 13 |
 $\frac{4}{4}$ 13-1 | 13-2 | 13-3 | 13-4 | 13-5 |
 $\frac{4}{4}$ 13-6 | 13-7 | 14 | etc. ————— = Streamer
 (visual aid to catch cue)

10-2	140.49	3.42	5.13	6.83	8.54
10-3	138.80	3.46	5.19	6.92	8.64
10-4	137.14	3.50	5.25	7.00	8.75
10-5	135.53	3.54	5.31	7.08	8.85
10-6	133.95	3.58	5.38	7.17	8.96
10-7	132.41	3.63	5.44	7.25	9.06
11	130.91	3.67	5.50	7.33	9.17
etc.	etc.	etc.	etc.	etc.	etc.

(To review the appropriate equations, see the formulas for time duration/click track/total measures/total beats.)

Variable click track. With a variable click track the basic time unit varies. A situation may arise where the tempo of a marching band or a dance routing increases or decreases to a barely perceptible degree during a particular sequence. The change of tempo in the final scoring may be distributed over a number of beats or measures depending on the time available.

Example: The following shows how one would score going from a click track of 12-4 (metronomic speed = 115.20) to a click track of 14 (metronomic speed = 102.857).

This concludes a basic discussion of film scoring math. The same principles can also be used in jingle work, demonstration tapes and records, and the like.

BY PROFESSIONAL DEMAND

DDC OFFERS FREE ADVICE, PERSONAL SERVICE AND ONE-DAY SHIPPING OF THE FINEST MUSIC AND SOUND EQUIPMENT AVAILABLE ANYWHERE:

CROWN Traynor
EV KORG polyfusion
 KELSEY
TEAC Strobotuner
MXR
RM
LP Zildjian
DiMarzio
TAPCO U
REMO
CRUMAR (Cherheim)
YAMAHA
SHURE
whirlwind
prophet DMI
ROSS
KRAMER
ARP OSC
ASHLY
intersound

PLEASE CALL OR WRITE FOR PRICES & ORDERING INFORMATION - YOU'LL BE GLAD YOU DID!

DDC DICKSTEIN DISTRIBUTING COMPANY
 1120 QUINCY PPK-SCRANTON, PA 18510
 PHONE ORDERS WELCOME (717) 344 7469

WIND PLAYERS VOCALISTS

You can use your own instrument or voice to control any standard synthesizer, with more expressiveness than a keyboard.



THE GENTLE ELECTRIC PITCH AND ENVELOPE FOLLOWER

Write for our free detailed brochure, patch diagrams, and application notes.

Also available as modules for Arnes and Serge synthesizers, or as circuit boards for custom systems. Dealers inquiries welcome.

gentle electric

Dept P
P.O. Box 132, Delta, CO 81416
(303) 874-7171

re-view

continued from page 12

Ricky Starbuster **ESP** (cassette). Another hour and a half with a star of the future, introduced here August '83. This time the whole first side features 6-year old Anna Fleer on improvised vocals, and she might end up being a bigger star than Ricky! For now she's most effective in small doses. The second side is divided into "Music for Relaxation" and "Music for Crazyness" (sic), and as before, Ricky's synthesizer work is an inspiration. \$8.50 postpaid from Starbuster Productions, PO Box 5582, Madison, WI 53705.

Danna & Clement **A Gradual Awakening** (cassette). The subtitle says it all: "Gentle electronic environmental music". The former classical wiz Mychael Danna teams up with Tim Clement to produce a dreamy, very beautiful set. \$9 postpaid from Summerland Music, 361 Valanna Crest, Burlington, Ontario, Canada L7L 2K7.

E-Mu Systems **DRUMULATOR** **TRIGGER MODIFICATION**

By: Kevin Monahan

While the Drumulator's AC-coupled output trigger pulse works with many devices (Sequential Circuits Poly Sequencer, Prophet-10 sequencer, and Pro-One arpeggiator; Roland MC-4; etc.), for some applications the pulse is not wide enough. This is because polyphonic keyboards, which use digital circuitry to scan the keyboard (this process checks for key closures), typically need a minimum 10 ms wide pulse. Devices which require a wider pulse width include the Prophet-600 and the Roland JP-4, JP-8, Juno 6, and Juno 60 arpeggiators.

Fortunately, there's a simple mod which DC-couples the pulse output and also stretches the pulse width if desired. First, make sure that the AC power cord is unplugged. Next, unscrew the case's bottom plate, then the screws which hold the circuit board in place. To DC-couple the pulse, locate C75 (towards the row-of-jacks side of the board); remove it, then replace it with a jumper. Note that the Drumulator board is a double-sided circuit board with extremely tight traces. So, use a solder wick or solder sucker to absorb the solder around C75's connections, and remove the capacitor very gingerly. If you don't want to go to the trouble of removing C75, just add the jumper across its terminals. Solder with a fine-tip, low wattage iron and be careful -- a modification like this voids the warranty.

Next, install a double pole, single throw switch on the back of

the Drumulator. You will need to drill a hole to do this; a good place is right below the word MIX OUT. Of course, make sure that an errant drill bit doesn't cause problems and drill through more than what you had intended.

Solder a 0.2 uF capacitor across both wipers of the switch (see figure 1), then solder two lengths of wire to the remaining switch contacts. Solder the other end of one of the wires to pin 6 of IC 15E, and the other end of the remaining wire to pin 7 of IC 15E. It doesn't matter which wire goes to which pin. The best place to connect these wires is the feedthrough holes next to both pins 6 and 7 of IC 15E. When you close the switch, the new 0.2 uF capacitor is in parallel with an existing 0.02 uF capacitor (C76), which stretches the pulse width.

Note that changing the capacitor value affects the sound of the metronome, which is why we've included a switch. When creating segments, it's better to use the original value (0.02 uF) as this gives the tightest metronome click sound. Switch the 0.22 uF capacitor in parallel when synching to other machines.

Re-mount the circuit board in the case (checking that none of the play buttons chafe against the case), then re-mount the bottom plate. Your Drumulator should now work properly with virtually any scanned polyphonic keyboard, as well as with other devices having similar pulse width requirements.

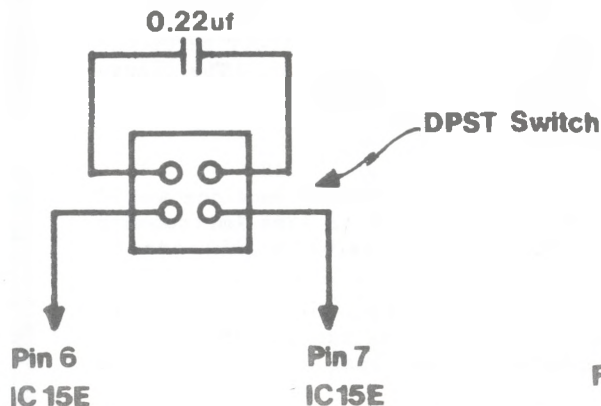

FIG. 1

CURRENT EVENTS

'Tell Them You Saw It In Polyphony'



Just a Minute... The latest delay from Electro-Harmonix (27 West 23rd St., New York, NY 10010) can delay up to a minute total, and up to 8 seconds with 12 kHz bandwidth. It includes click track, sound-on-sound with infinite hold, reverse playback, echo taps, readout, and so on. The 64 Second Digital Looping Recorder lists for \$1195.

Music software. Passport Designs (116 North Cabrillo Hwy, Half Moon Bay, CA 94019) has announced several new software packages. THE MIDI NETWORK software consists of an interface card and drum timing generator; it works like a multi-track recorder, with "punch in" and "punch out" capabilities for editing. It requires an Apple II or equivalent, 48 or 64K RAM, one disk drive, monitor, and of course, a MIDI equipped synthesizer.

Passport's other software packages are for music business. These include PICKERS (for singers and musicians who earn their living through studio and live performing), WRITERS (for composers and songwriters who earn their living through royalties), TOUR (for touring musicians and bands); enhanced versions of all three packages are also available.

New newsletter. Polyphony author Bill Rhodes has started "Approach", which is a medium for information about tapes, EPs, LPs, and videos from independent record companies. "Approach" currently covers the NY, NJ and CT tri-state area, and includes reviews of local and/or national indy releases along with info on how to

obtain the music. For ad rates and further info, write Jazzical Records, 6707 Victoria Ct., Edison, NJ 08817. A sample issue is available for \$1.00.

Wireless mic. Nady (1145 65th St., Oakland, CA 94608) has introduced the Nady 49 VR, a miniature receiver that attaches to video or movie cameras. When used with the Nady 49 LT wireless lavalier mic transmitter or the Nady 49 HT handheld wireless mic, the 49 VR provides audio for any model camera without the bother of long cords. Typical operating range is up to 100 feet.

Apple II Sound Digitizing. Decillionix (PO Box 70985, Sunnyvale, CA 94086) has introduced the DX-1 sound processing system for the Apple II. With the DX-1 up to 10 seconds of sound can be entered, saved, processed, sequenced, and generally modified under computer control; additional software allows for echo, reverb, and other real time sound processing features.

One of the six software "menus" allows a collection of pre-recorded drum sounds to be played on the Apple keyboard. Another menu provides "random" reproduction of real sounds. Sounds can be played in reverse or

stored on diskette.

The DX-1 lists for \$239 and requires an Apple II or IIe, DOS 3.3, and Applesoft BASIC. Call 408/735-0410 for a 24 hour demo.

Monolithic peak detector. PMI (1500 Space Park Drive, Santa Clara, CA 95050) has introduced the PKD-01 peak detector with reset and hold mode. The chip includes two gated transconductance amps feeding an output buffer and an uncommitted comparator.

Singing speech synthesizer. The Alien Group (27 West 23rd St., New York City, NY 10010) has released the VOICEBOX speech synthesizer for VIC 20 and Commodore 64 computers. It not only synthesizes speech but "sings" in tune as well. \$95 list.



Dolphin talk. Syntauri (4962 El Camino Real, Los Altos, CA 94022) has introduced Dolphin Dialogue, which allows Syntauri/Apple systems to create dolphin-like sounds. \$39 list; profits go to the Cetuman Foundation, which funds the Institute for Delphinid Research human/dolphin communications project.

A Lofty limiter. Loft (91 Elm St., Manchester, CT 06040) has introduced the Model 400 quad limiter and noise gate for recording and sound reinforcement applications. \$649 list.



POLYMART

BOOKS

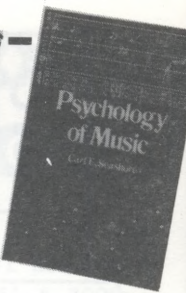
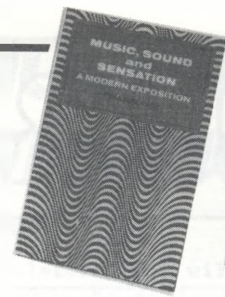
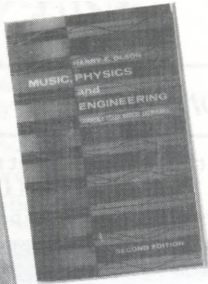

SCIENCE OF SOUND

The physical and psycho-acoustical background to music is an important part of musical synthesis. Helmholtz's **SENSATION OF TONE** is, a century after its publication, still the standard text for the physiological acoustics. **PSYCHOLOGY OF MUSIC** by Carl Seashore, developer of the Seashore Music Test, provides an in-depth analysis of musical style and performance characteristics of many instruments. **MUSIC, PHYSICS AND ENGINEERING** by Harry Olson, who worked on the first RCA synthesizer, is a thorough discussion of the physical properties and design of traditional musical instruments (plus a chapter on electronic music). **MUSIC, SOUND AND SENSATION** by Winckel is much like the Helmholtz work, with a bit less detail and more concentration on psycho-acoustics.

#PSYCH	PSYCHOLOGY OF MUSIC	\$6.00	#SENS	ON THE SENSATIONS OF TONE	\$8.95
#MSS	MUSIC, SOUND AND SENSATION	\$4.50	#MPE	MUSIC PHYSICS AND ENGINEERING	\$6.50

REFERENCE

Often used reference materials to answer the many questions encountered in everyday synthesis. **THE SOURCE** Book of Patching and Programming from Polyphony has over 125 pages of patches in universal flow chart notation; the largest publication of its type. **AUDIO CYCLOPEDIA** has 1760 pages with 3650 entries and hundreds of drawings and schematics to answer any question about ratio. Hardbound. **ELECTRONIC MUSIC SYNTHESIZERS** by Delton Horn devotes the first half to descriptions and functions of commercial electronic music synthesizers (Moog, Arp, PAIA, Oberheim, EML, and RMI); the second section provides schematics and projects for the experimenter.

#SOURCE	THE SOURCE	\$4.00
#CYCLO	AUDIO CYCLOPEDIA (hardbound)	\$44.95
#EMS	ELECTRONIC MUSIC SYNTHESIZERS	\$6.95

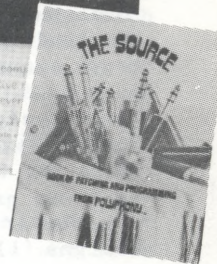
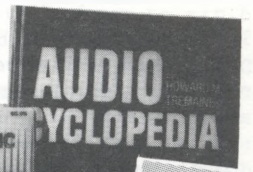

TECHNIQUE

Synthesists must be well versed in a number of techniques and principles. "How To" and project oriented books are a great way to pick up these skills. **MULTITRACK PRIMER** by TEAC is a step-by-step guide to building, outfitting and operating your home studio. The Byte Book of **COMPUTER MUSIC** describes computer control of electro-mechanical instruments, Fourier analysis, circuits and loads of software. **HOME RECORDING FOR MUSICIANS** is Craig Anderton's original guide to outfitting and operating a budget studio for maximum results, includes mixer and other audio processing circuits and a sound sheet demo recording.

#TEAC	TEAC MULTITRACK PRIMER	\$4.95
#BYTE	BYTE BOOK OF COMPUTER MUSIC	\$10.00
#HRFM	HOME RECORDING FOR MUSICIANS	\$11.95

"HOW TO" GUIDES

HOW TO BUILD A SMALL BUDGET RECORDING STUDIO FROM SCRATCH by F. Alton Everest covers twelve tested designs. **HOW TO DESIGN TEST AND BUILD COMPLETE SPEAKER SYSTEMS** BY David Weems is a do-it-yourself guide for the ultimate in sound quality. **HOW TO MAKE AND SELL YOUR OWN RECORD** — With the major labels having severe economic problems, many insiders feel that the future of the music industry may be in independent record production. Learn the ropes with Diane Sward Rapaport's indispensable handbook of how to get started. **MAKING MONEY MAKING MUSIC** by James Dearing — Everyong dreams of being at the top, but there's an enormous amount of "middle money" out there for the taking. This is not a book about how to become a Millionaire Rock Star, but the strategies revealed will give you the knowledge you need to keep afloat if you decide to pursue a recording contract. A fresh and practical approach to staying alive in the music business. From the publishers of Writer's Digest.

#BRS	BUDGET RECORDING STUDIO	\$9.95	#MASR	MAKE & SELL YOUR OWN RECORD	\$11.95
#CSS	COMPLETE SPEAKER SYSTEMS	\$7.95	#MMM	MAKING MONEY MAKING MUSIC	\$12.95

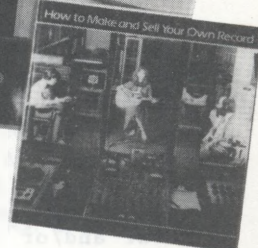
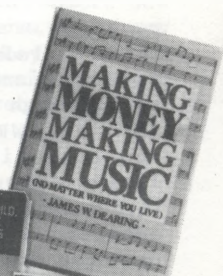
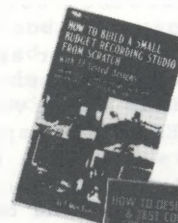

ORDER FROM: POLYMART, P O BOX 20305, OKLAHOMA

USE THE ORDER FORM ON THE NEXT PAGE

ELECTRONICS

Electronic Cookbooks are a great way to stock your library with materials that are not only heavy on theory, definitions and educational material but chock full of practical applications as well. These books can easily replace stacks of manufacturers data sheets and applications notes all in an easy to use reference. Walt Jung's **OP-AMP** and Don Lancaster's **ACTIVE FILTER** Cookbooks are self-explanatory — required reading for synthesists! **AUDIO OP AMP APPLICATIONS** is an edited version of the Op Amp Cookbook by Walter Jung, containing only audio applications. Lancaster's **CMOS** book is much more than a digital reference — phase lock loops, top octave generators, touch switches, and other things you need. **ELECTRONIC PROJECTS FOR MUSICIANS** by Craig Anderton is almost in a class by itself. It discusses electronic construction technique for the novice and provides 27 projects with printed circuit board patterns and a demo recording of the effects. Even if you're an old hand at musical electronics, you'll appreciate that all of these processors, from Tube sound Fuzz to Phase shifter are compatible and work together without creating noise, signal loss, bandwidth compression or any of the problems common to interconnecting effects from different manufacturers. There's even a complete chapter on how to modify and combine effects to produce your own custom pedalboard. **ELECTRONIC MUSIC CIRCUITS** by Barry Klein covers synthesizer system design, power supplies, control voltage generators, VCOs, Filters, analog multipliers and more. Lots of schematics and data sheets on the most popular music oriented ICs. An excellent technical reference.

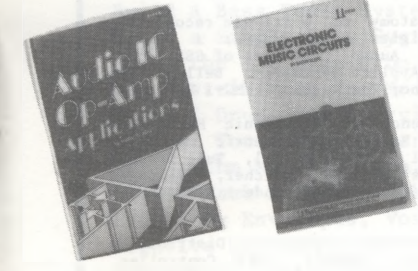
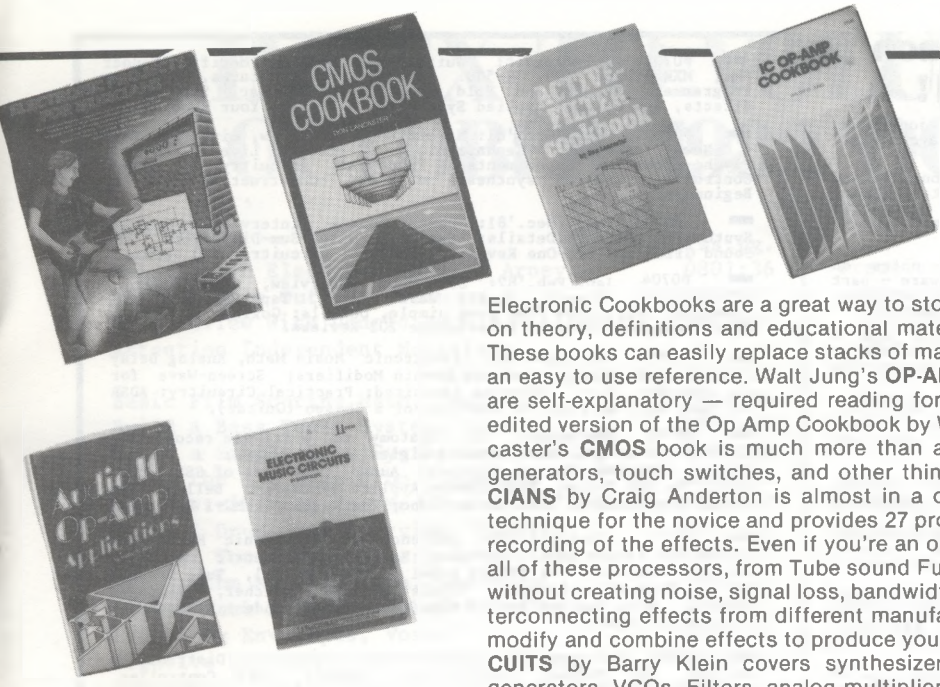

- | | | | | | |
|-------|---------------------------|---------|-------|-----------------------------------|---------|
| #OACB | OP-AMP COOKBOOK | \$15.95 | #EPFM | ELECTRONIC PROJECTS FOR MUSICIANS | \$14.95 |
| #AFCB | ACTIVE FILTER COOKBOOK | \$14.95 | #EMCR | ELECTRONIC MUSIC CIRCUITS | \$16.95 |
| #AUOA | AUDIO OP-AMP APPLICATIONS | \$9.95 | #CMCB | CMOS COOKBOOK | \$12.95 |

EXCITING NEW BOOKS!

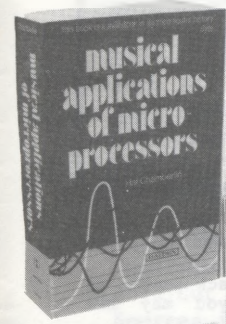

NEW

MUSICAL APPLICATIONS OF MICRO-PROCESSORS by Hal Chamberlain — If you only have space in your library for one book on music synthesis, this is the book. The easily read text is entertaining and enlightening and teaches both basics and advanced theory without plowing through pages of equations. Liberal examples illustrate theory and practice of both digital and analog signal generation and processing.

- | | | |
|------|--|---------|
| #MAM | MUSICAL APPLICATIONS OF MICRO-PROCESSORS | \$19.95 |
|------|--|---------|

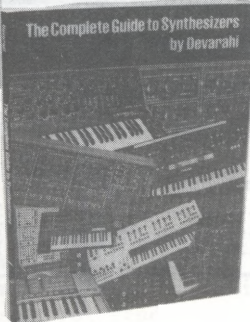

THE COMPLETE GUIDE TO SYNTHESIZERS by Devarahi — An extraordinarily thorough treatment of the subject of analog synthesizers. Covers everything clearly, and the suggested experiments are excellent. Well organized and leaves nothing out.

- | | | |
|------|------------------------------------|---------|
| #CGS | THE COMPLETE GUIDE TO SYNTHESIZERS | \$15.95 |
|------|------------------------------------|---------|

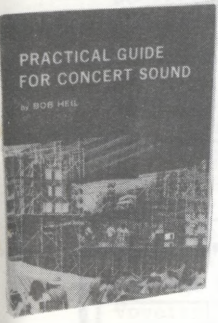

NEW

PRACTICAL GUIDE FOR CONCERT SOUND by Bob Heil — Finally, a manual that explains in very simple language those many "magic terms" you've heard for years and never really understood. It's the first book written especially for musicians, roadies, and sound technicians who want to KNOW and UNDERSTAND what their sound system is all about.

- | | | |
|------|-----------------------------------|---------|
| #PGC | PRACTICAL GUIDE FOR CONCERT SOUND | \$10.00 |
|------|-----------------------------------|---------|

& MORE FROM POLYPHONY

4/8TRACK STUDIO LOG BOOK designed by Craig Anderton provides a place to keep all the important information on your tape library. Log in timing, type of tape used, record patches, make notes and use the expanded track sheet to list sequential changes in tape tracks relating to the settings of the index counter. Craig Anderton's **CONTEMPORARY KEYBOARD ARTICLES** is a collected reprint of all the articles from June 1977 through February 1981, covers tips, technique, theory, maintenance, and numerous construction projects. **DEVICE BACK ISSUES** — during the year that this newsletter was published, it featured almost 200 pages of technical information for the guitarist/musician. A wealth of articles on design, product reviews, and modification and construction projects. Sold in complete set, individual issues not available. Limited number available. **CRAIG ANDERTON MUSIC TAPE** — Delightful listening plus a booklet explaining how the effects were achieved.

- | | | |
|---------|---|---------|
| #SLB | STUDIO LOG BOOK | \$4.95 |
| #AA | CRAIG ANDERTON'S CONTEMPORARY KEYBOARD ARTICLES | \$5.95 |
| #DEVICE | COMPLETE SET (12) DEVICE BACK ISSUES | \$18.00 |
| #CAMT | CRAIG ANDERTON MUSIC TAPE | \$5.95 |



A CITY, OK 73156 (405) 842-5480

BACK ISSUES \$ 2.50 each ppd

Find out what you've missed!

- #0303: 2/78: computer controlled Gnome, using joysticks, build a bionic trumpet, ultra-VCO modifications, voltage control the Mu-Tron Bi-Phase, oral joystick, patches.
- #0304: April/May 78: Minimoog modifications, non-keyboard module use, phasing and flanging (theory and circuits), memory expansion for programmable drums, digitally addressed transposer project, polyphonic software (with software transient generators), patches, Volume 3 index.
- #0402: Sept/Oct 78: electronic music notation, notes on the recording of "Cords" by Larry Fast, sequencer software - part one, rhythmic control of analog sequencers, touch switch projects, modular vocoder techniques, PET as a music controller, patches.
- #0404: January/March 79: add-ons for vocal F and V converter, shorthand patch notation, more on note to frequency conversion, graphic monitor project, George Russell, super VCA circuit, echo software, Vol. 4 index.
- #0502: July/August 79: hex VCA/mixer project, electronic music schools and studios, modify the Oberheim Expander Module, profile of Ernest Garthwaite, budget microphones, digitizer projects and software, bar graph ICs.
- #0505: January/February 80: Joseph Byrd, Mort Garson, Larry Fast on 'Games', composing for 'live plus tape', using the CA3280, recording vocals, ADSR circuits.
- #0506: March/April 80: Computers in Music: real time audio processing hardware, Powell sequencer system, Max Mathews, advanced STG software, PortaStudio, phase modulation, Volume 5 index.
- #0601: May/June 80: Gary Numan, Microcomputers in Real Time Audio, Build a Digital Audio Delay Line, writing Documentation, Richard Hayman Composer/Performer Home Recording: Applying Harmonizing and Pitch Transposing Techniques by: Craig Anderton.
- #0602: July/August 80: Peter Gabriel, digital VCO project, ream modules, optimum level settings, dynamic phrasing, patches.
- #0603: Sept/Oct combined with Nov/Dec 80: alternate controllers, add voices to Casio M-10, voltage controlled quadrature oscillator project, cordless patch bay, recording rules, patches.
- #0604: January/February 81: Special Construction Edition; Build: Audio Circuit Breaker, Pulse Width Multiplier, Magnetic Harp, 50 Watt/Channel Stereo Power Amp, Quad Sequential Switch, DOD Mods, patches.
- #0605: March/April 81: Portable Music Issue, reviews of Remco's FX, E-H Mini-synthesizer, Casio's VL-Tone, plus mods for the M-10, GR-500, mini-amp, and the Korg X-911. Introducing; Practical Circuitry and On Location, new columns.
- #0606: May/June 81: Synthesizer: Hardware Mods and Software. Modular Synthesizer Effects, Environmental music, Keyboard assignment for the 8700, new columns; Details, Practical Circuitry, and On Location. Volume 6 index.

- #0701: July/August: Guitar Electronics: Modify: Fender Amp, MXR Phase 100, GR-500. Input/Output Structures, \$5 Analog Programmer, Sample and Hold technique, Modular Synthesizer Effects, new column: Applied Synthesis, Marketing Your Records.
- #0702: Sept./Oct.'81: Harald Bode Interview, Live Plus Tape - New Technique, Xenharmonics, Kraftwerk Live - Review, Psycho-Acoustic Experiments, Practical Circuitry - Super Controller, Applied synthesis - Brass, Construction Tips For Beginners.
- #0703: Nov./Dec.'81: Dave Rossum interview, Applied Synthesis: Strings, Details: Series-parallel/Sum-Difference. The Sound Gizmo and Pro-One Reviews, Practical Circuitry: VCO Deluxe.
- #0704 Jan./Feb.'82: Bob Moog interview, Chip Power - STK-050/070, Simple Square Wave Shaper, Tape Timer Ruler, Practical Circuitry: VCAs made simple, Details: Gozinda & Gozouta Revisited, Korg Trident & Casiotone 202 Reviews.
- #0705 Mar./Apr.'82: Electronic Music Math, Analog Delay Clock / Modulation; Frequency Domain Modifiers; Screen-Wave for the TRS-80; Touch Switches Revisited; Practical Circuitry: ADSR the Easy Way; Getting the most out of a Cheapo (Guitar).
- #0706 May/August '82: Anatomy of a Private record, Don Slepian Interview, Understanding Digital Synthesizers: A Digital Filter, Syn-Bow Review, Optical Audio, Profiles of SSM 2033 & 2044, The PAL Filter, Bill Rhodes Applied synthesis: Bells, Pipe Organ, Harpsichord, Electronic piano; The Realistic MG-1 Reviewed.
- #0801 Sept/Oct.'82: Ambience in Electronic Music, Tone Bypass for Fender Amps, 8 Track Reviews, Parametric EQ Tips, Solo/Cut Circuit for TASCAM Model 3, The SSM 2011, Tube Preamp, Snare + Drum Voice Circuit, Triple Pick-up Switcher, Simulated Stereo, When Quality Record Mfg. Counts, Independent Record Mfg. Convention report.
- #0802 February '83: AMS-100 Gate Output, Bus Distribution Modules for Modular Synthesizers, Dynamic Touch Controller, Expanding Envelopes, MXR Limiter Review, New Age Music, An Overview, Synsonics Drum Review, Interface, Practical Circuitry: A Patch Over Scheme for Small Synthesizers, Lab Notes: Shepard Functions.
- #0803 April '83: Sound Interface Device, Build a Bass Pedal System, Dr. Rhythm Mod., Switched Capacitance/Transversal Filters, Voltage Controlled LFO, Rockman & Voyetra Eight Reviews.
- #0804 June '83: MIDI Hardware Fundamentals, What MIDI Means for Musicians, The Vangelis Interview, Creative Recording on a Shoestring Budget, A One Chip ADSR, An Electronic Switch.
- #0806 August '83; Donald Buchla Interview, An Overview of Digital Drums, Exploring Just Intonation, Build a simple Drum Synthesizer, Micro-Drums part I, The Penultimate Compressor, Why Spring Reverb Will Never Die, Gate/Sample & Hold Circuit.

CASIO M-10 OWNERS.....

Did you realize that your pride and joy has unseen powers? That there are voices and effects that you can add for the cost of a switch and a piece of wire? This latest booklet from POLYPHONY gives you the info that you need to transform your mini-axe and gives details on adding a "stunt box", computer interfacing and much, much more.

No. CMOD 16 pages\$3.50

SSM 2011 CHIPS

As a special service to readers interested in evaluating this exciting new chip, for a limited time POLYMART offers the SSM 2011 Microphone Preamp/Level Detector IC. No. 2011\$5.75 each plus postage (\$1.00)

RACK PANEL SPECIAL!

Easily machined 1/8 inch unfinished aluminum rack panels as low as \$3.95 each in quantities of 3 or more. (you may mix sizes for discount prices)

	Quantity	
	1	3 or more
single size - 1-3/4".....	\$5.25	\$3.95 each
double size - 3-1/2".....	\$9.25	\$7.95 each
triple size - 5-1/4".....	\$12.95	\$11.95 each

ORDER FORM

We cannot invoice: payment must be enclosed with your order. there is a flat \$.50 handling fee per order plus postage costs. MasterCharge and Visa are welcome. (\$10.00 minimum charge). Foreign orders **must** be paid by certified check or money order in U.S. \$ drawn on a U.S. bank (or by charge card). Phone orders welcomed for charge card orders.

SHIP TO:

Name: _____
 Address: _____
 City _____ State _____ Zip _____



Card # _____
 MasterCharge Bank # _____ Expiration Date _____
 Signature _____

Quantity	Item	price ea.	amount
SUBSCRIPTION		U.S. \$12/YR. FOREIGN \$14/YR.	
Shipping Charges			sub total
U.S.: add 10% of SubTotal or \$5.00 maximum			handling .50
Foreign: 20% of SubTotal or \$10.00 maximum			shipping
			total enclosed

MAIL TO: POLYMART, P O BOX 20305, OKLAHOMA CITY, OK 73156

INDEX TO VOLUME EIGHT OCTOBER 1982 OCTOBER 1983

FEATURES:

	Vol, Iss: pg.
Ambience in Electronic Music, Arney	0801:36
AMS-100 Gate Output, Orman	0802:07
An Interview With Donald Buchla, Diliberto	0805:14
Attention Independent Musicians, Carlberg/Anderton	0801:25
Basic Film Scoring Math, Deutsch	0806:24
Build A Bass Pedal System, Hawk	0803:17
Build a Simple Drum Synthesizer, Young	0806:36
Build the Hip Bass Drum, Anderton	0806:13
Bus Distribution for Modular Synth's, Lauria	0802:47
Digital Drums, An Overview, Anderton	0805:22
Dynamic Touch Controller, Beausoleil	0802:30
Dr. Rhythm Modification, Anderton	0803:29
Eight-Track Reviews, Aikin & Styles	0801: 8
Expanding Envelopes, Vosh	0802:28
Creative Recording on a Budget, Horn	0804:16
Electronic Switch for Musicians, DiFrancesco	0804:19
E-Mu Drumulator Trigger Mod; Monahan	0806:28
Exploring Just Intonation, Doty	0805:38
Fender's Triad Interface	0805:43
Fostex X-15 Review, Mulhern	0806:22
Gate-Sample/Hold Circuit, Rogalski	0805:20
Independent Record Mfg. Convention, Trythal	0801:32
Larry Fast Interview, Anderton	0806: 8
Meet SID Sound Interface Device, Lisowski	0803:33
MIDI Hardware Fundamentals, Junglieb	0804:34
MXR Limiter Review, Anderton	0802:19
MXR Omni Effects System a Review, Montgomery	0804:39
New Age Music Overview, Schwartz	0802:17
Parametric EQ Tips, Doty	0801:18
Pedal Board Tip, Figuerido	0801:19
Simulated Stereo, Deleersnyder	0801:26
Solo/Cut Circuit for TASCAM Model 3, Haisley	0801:27
Sources in Acoustics, Doty	0803:30
SSM 2011, Dow	0801:34
Switched Capacitance/Transversal Filters, Quiroga	0803:12
The Penultimate Compressor, Figueiredo	0805:10
The Rockman Cometh, Austin	0803:10
The Vangelis Interview, Diliberto	0804:20
Tone By-pass For Fender Amps, Morrison	0801:12
Triple Pick-up Switcher, Suggs	0801: 7
Tube Preamp, Orman	0801:24
Veloci-Touch/Pro-One Interface, Wood	0802:12
Voltage Controlled LFO, Anderton	0803:36
Voyetra Eight Review, Styles	0803: 8
What MIDI Means For Musicians, Wright	0804:08
When quality Record Mfg. Counts, Rapaport	0801:15
Why Spring Reverb Will Never Die, O'Donnell	0805:18

COLUMNS:

Applied Synthesis:, Rhodes	
Orchestral Voicings using Tenth Interval	0806:16
Poly-61 Review	0804:41
Synthetic Choir	0802:10

Lab Notes:, Simonton	
Shepard Functions	0802:42

Details:, Bohn	
The Audio Connection,	0803:16

Practical Circuitry:, Henry	
Micro-Drums part I	0805:32
Micro-Drums part II	0806:18
One Chip ADSR	0804:30
Transistor Circuits	0803:26
Patch Over Scheme For Small Synthesizers	0802:26
Snare Plus Drum Voice Circuit	0801:28

Re-View, Carlberg	
0806: 6, 0805:04, 0804: 6, 0803:6, 0802: 6, 0801: 5	

Book Review, Doty	
Electronic Music systems, techniques and controls	0805:09
The Complete Synthesizer	0804:32

On Location:	
Alaska, Stirling	0804:05
Concerts, US Festival, NAMM; Anderton	0805:05
Northern CA, Anderton	0802:36

U.S. Postal Service STATEMENT OF OWNERSHIP, MANAGEMENT AND CIRCULATION (Required by 39 U.S.C. 3685)		
1A. TITLE OF PUBLICATION POLYPHONY	1B. PUBLICATION NO. 0 1 6 3 3 5 3 h	2. DATE OF FILING 10/1/83
3. FREQUENCY OF ISSUE bi-monthly	3A. NO. OF ISSUES PUBLISHED ANNUALLY 6	3B. ANNUAL SUBSCRIPTION PRICE \$12.00
4. COMPLETE MAILING ADDRESS OF KNOWN OFFICE OF PUBLICATION (Street, City, County, State and ZIP Code) (Not printer)		
1020 W. Wilshire Blvd., Oklahoma City, OK 73116		
5. COMPLETE MAILING ADDRESS OF THE HEADQUARTERS OF GENERAL BUSINESS OFFICES OF THE PUBLISHER (Not printer)		
1020 W. Wilshire Blvd., Oklahoma City, OK 73116		
6. FULL NAMES AND COMPLETE MAILING ADDRESS OF PUBLISHER, EDITOR, AND MANAGING EDITOR (This item MUST NOT be blank)		
PUBLISHER (Name and Complete Mailing Address) John S. Simonton, Jr., 1020 W. Wilshire Blvd., Oklahoma City, OK 73116		
EDITOR (Name and Complete Mailing Address) Craig Anderton, 1020 W. Wilshire Blvd., Oklahoma City, OK 73116		
MANAGING EDITOR (Name and Complete Mailing Address) Linda Kay Brunfield, 1020 W. Wilshire Blvd., Oklahoma City, OK 73116		
7. OWNER (If owned by a corporation, its name and address must be stated and also immediately thereunder the names and addresses of stockholders owning or holding 1 percent or more of total amount of stock. If not owned by a corporation, the names and addresses of the individual owners must be given. If owned by a partnership or other unincorporated firm, its name and address, as well as that of each individual must be given. If the publication is published by a nonprofit organization, its name and address must be stated. (Item must be completed.)		
FULL NAME COMPLETE MAILING ADDRESS		
PATA-Electronics, Inc. 1020 W. Wilshire Blvd., Oklahoma City, OK 73116		
John S. Simonton, Jr. 1020 W. Wilshire Blvd., Oklahoma City, OK 73116		
John S. Simonton, Jr. 1020 W. Wilshire Blvd., Oklahoma City, OK 73116		
8. KNOWN BONDHOLDERS, MORTGAGEES, AND OTHER SECURITY HOLDERS OWNING OR HOLDING 1 PERCENT OR MORE OF TOTAL AMOUNT OF BONDS, MORTGAGES OR OTHER SECURITIES (If there are none, so state)		
FULL NAME COMPLETE MAILING ADDRESS		
NONE		
9. FOR COMPLETION BY NONPROFIT ORGANIZATIONS AUTHORIZED TO MAIL AT SPECIAL RATES (Section 475.12 DMR only) The purpose, function, and nonprofit status of this organization and the exempt status for Federal income tax purposes (Check one)		
<input type="checkbox"/> (1) HAS NOT CHANGED DURING PRECEDING 12 MONTHS <input type="checkbox"/> (2) HAS CHANGED DURING PRECEDING 12 MONTHS (If changed, publisher must submit explanation of change with this statement.)		
10. EXTENT AND NATURE OF CIRCULATION		
A. TOTAL NO. COPIES (Net Press Run)	3500	3500
B. PAID CIRCULATION	1150	980
1. Sales through dealers and carriers, street vendors and counter sales		
2. Mail Subscriptions	2100	1965
C. TOTAL PAID CIRCULATION (Sum of B1 and B2)	3250	2945
D. FREE DISTRIBUTION BY MAIL, CARRIER OR OTHER MEANS SAMPLES, COMPLIMENTARY, AND OTHER FREE COPIES	150	120
E. TOTAL DISTRIBUTION (Sum of C and D)	3400	3065
F. COPIES NOT DISTRIBUTED	100	435
1. Office use, left overs, unaccounted, spoiled after printing		
2. Return from News Agents	0	0
G. TOTAL (Sum of E, F1 and F2 - should equal net press run shown in A)	3500	3500
11. I certify that the statements made by me above are correct and complete		
SIGNATURE AND TITLE OF EDITOR, PUBLISHER, BUSINESS MANAGER, OR OWNER John S. Simonton, Jr., Publisher		

PS Form 3526
July 1982 3026

(See instruction on reverse)

EQUIPMENT EXCHANGE

PUT POLYPHONY TO WORK FOR YOU. List equipment for sale or trade, job openings, positions wanted, etc. Equipment exchange classified rates for individuals offering goods or services for sale or trade: 25c per word, 20 word (\$5.00) minimum charge; Commercial establishments: 50c per word. Prices, zip, phone numbers count as one word each. DISPLAY CLASSIFIED: \$15 per column inch, one inch minimum, camera ready art to be supplied by advertiser. All classified advertising must be prepaid. Advertisers using a Post Office Box number for responses must furnish Polyphony Publishing Co. with a complete street address and phone number. Readers should respond directly to advertiser. Polyphony is not responsible for claims made in ads, or for the results of any transactions. Polyphony reserves the right to edit or refuse any ads submitted.

SALE

★ NEW ★

Moog MEMORYMOOG "PLUS": Dual Sequencer, MIDI, Drum Machine Interface, \$2950 ppd.
 MOOG SL-8 DIGITAL SYNTHESIZER: Call for price.
 CASIO CT-7000: 8-voice Poly, internal sequencer & drum machine, cassette interface, \$665 ppd.
 SIMMONS DRUMS' CLAPTRAP: Handclap synthesizer, with external trigger, \$255 ppd.
 Electro-Harmonix FREQUENCY ANALYZER: Ring Modulator. Quiet, AC-Powered, \$139 ppd.
 DECILLIONIX DX-1 Apple Audio Recorder: Use your Apple-compatible computer as a digital audio recorder, \$239 ppd.

DIGITAL

CASIO CT-610: Scaled-down CT-7000, \$475 ppd.
 360 SYSTEMS DIGITAL KEYBOARD: Incl. Anvil ATA case, 16 instrument sounds, \$3995 ppd.
 ELECTRO-HARMONIX:
 16 SEC DIGITAL DELAY: With looping, \$395 ppd.
 64 SEC DIGITAL DELAY: Rack-mount, \$995 ppd.
 "INSTANT REPLAY": 2 second digital recorder w/ looping, triggered by percussion controller (incl.), or transposed by synthesizer control, \$195 ppd.

COMPUTER

SOUNDCHASER II: Complete system including Turbo Traks, Demo disk, \$1350 ppd. Plus one additional Software Title free.
 MOUNTAIN COMPUTER MUSIC SYSTEM: Complete, for all Apple-compatible computers, \$349 ppd.

MOOG

MEMORYMOOG: \$2500 ppd.
 ROGUE Synthesizer: \$322 ppd.
 VINTAGE MOOG: Minimoog, Multimoog, Polymoog, Prodigy—new and reconditioned units in stock.

SERVICE

All items carry a full factory warranty.
Musitech™ is a factory-authorized Service Center for Moog, 360 Systems, E-mu, Simmons Drums, and others. We service what we sell. We do custom mods.

SHIPPING

All items are now shipped via UPS or PRIORITY Mail. Free shipping on prepaid orders.
It's an exciting time to be involved in electronic music.

Musitech™

1631-A East 25th Street
 P.O. Box 3717
 Chattanooga, TN 37404
 (615) 624-5600

Music equipment

10 YEAR INVENTORY, must go. Name synths, custom equipment, parts, manuals, bound magazines - EN, CMJ. Much more; send want lists; make offers. Send SASE for list. SYNTHESIST, Box 1453, Novato, CA 94948.

KORG X911 Guitar Synthesizer \$600 list, make offer or trade. Jim Billington, 4739 - 326th Ave. N. E. Carnation, WA 98014, (206) 333-6167.

FOR SALE: PAIA P4700/J complete with software, manuals, EK-2 Drums, Shepard Function Gen. Best offer over \$1,200. K. Meyer, P.U.B. #753, Cheney, WA 99004, (509) 235-8109.

8785 Linear DAC, 8781 Quash and 25 Polyphony's (1/76 thru 8/81) all for \$60. Excellent shape. I'll pay shipping. Ken Winograd, 2039 Country Club, Manchester, NH 03102.

ELECTRONIC MUSIC KITS: Memory expansion units for Jupiter 4 and Promars synthesizers. Two versions available, 32 or 64 variable programs. Imported from West Germany. Also: Voice Modular System consisting of polyphonic computerized keyboard, voice cards, expansion card and computer interface. Compatible with most home computers. Send \$5.00 for brochures and demo cassette. Cedos Corp., 378 W. Main St., Waukesha, WA 53186.

KORG PS-3300 Polyphonic modular studio synth w/2 keyboards E.C. 2500, Korg Vocoder 675.00, Electro comp 200 modular synth 300.00, ARP 2600 - late model E.C. 850.00. Walt Whitney (314) 429-2858.

Great synthesizer introduction - PAIA OZ mini-organ 3760 with matching PAIA micro-synthesizer 3740. Custom built battery eliminator, "Super-Gnome" multi-triggering. Excellent condition, fully documented. Patch book included. \$175.00 or best offer, Don Vaillancourt, 18 Grove Street, Hopkinton, MA 01748.

Recordings

The best music "The Sunshine State" has to offer: PROJEKT ELECTRONIC SOUTH FLORIDA. A 45 minute cassette with nine artists. Ranging from EVERFRIEND (pseudo classical) to RADIO BERLIN (Euro-Dance) to BOB RUPE (Enoesque). Send \$4.50 check or money order to: Sam Rosenthal, c/o PESF; 8951 SW 53rd St., Cooper City, FL 33328.

AD INDEX

Blacet Music Research	4
Decillionix	5
Dickstein Distributing	27
Electro-Harmonix	7, 12
Equipment Exchange classified	34
Gentle Electric	28
PAIA	36, 4, 6
PGS Electronics	35
Polymart	30, 31, 32
Polyphony	6
Oberheim	2

PARTS and KITS from: PGS

LINEARS

TL061.....BiFet.....	.72
TL062.....Dual BiFet.....	.99
TL064.....Quad BiFet.....	1.95
TL071.....BiFet.....	.65
TL072.....Dual BiFet.....	1.15
TL074.....Quad BiFet.....	1.95
NE555.....Timer.....	.39
NE570.....Compander.....	3.80
NE571.....Compander.....	2.95
NE572.....Compander.....	4.95
UA741.....Comp. OpAmp.....	.29
MC1456.....Low Noise OpAmp.....	.90
RC1556.....Low Noise OpAmp.....	1.48
CA3080.....OTA.....	.94
CA3280.....Dual OTA.....	1.98
RC4136.....Quad OpAmp.....	1.10
RC4739.....Dual Low Noise.....	1.19
NE5532.....Dual High Perf.....	3.70
NE5534.....High Performance.....	2.65

SPECIAL PURPOSE

SAD-1024.....Analog Delay.....	17.50
SAD-4096.....Analog Delay.....	37.50
MK50240.....Top Octave Div.....	5.95
SN76477.....Sound Generator.....	3.45

SANYO HYBRID POWER AMPS

STK050.....50 Watt Power Amp.....	19.40
STK070.....70 Watt Power Amp.....	24.20

SSM - SOLID STATE MICRO-TECHNOLOGY

SSM 2010.....VCA.....	7.50
SSM 2011.....PreAmp.....	5.75
SSM 2012.....VCA.....	9.50
SSM 2020.....VCA.....	7.50
SSM 2022.....VCA.....	7.50
SSM 2030.....VCO.....	7.50
SSM 2033.....VCO.....	10.00
SSM 2040.....VCF.....	7.50
SSM 2044.....VCF.....	7.50
SSM 2050.....VCTG.....	7.50
SSM 2056.....VCTG.....	5.75

THERMISTER (Temp. Sensing Resistor)

TSR-Q81.....Tel Labs Q81 1k.....	\$3.50
----------------------------------	--------

OPTO-ISOLATOR

CLM6000.....Claiex CLM6000.....	\$2.85
---------------------------------	--------

CAPACITORS (25 volt)

701-100.....100 pf polystyrene.....	.25
701-180.....180 pf polystyrene.....	.25
701-1000.....1000 pf polystyrene.....	.25
701-2200.....2200 pf polystyrene.....	.25
701-2200.....3300 pf polystyrene.....	.25
701-3900.....3900 pf polystyrene.....	.25
702-005......005 uf mylar.....	.12
702-01......01 uf mylar.....	.12
702-05......05 uf mylar.....	.16
702-1......1 uf mylar.....	.21
702-22......22 uf mylar.....	.33
703-1.0.....1.0 uf tantalum.....	.39
703-3.3.....3.3 uf tantalum.....	.49
703-4.7.....4.7 uf tantalum.....	.59
704-2.2.....2.2 uf electrolytic.....	.21
704-4.7.....4.7 uf electrolytic.....	.21
704-10.....10 uf electrolytic.....	.21
704-100.....100 uf electrolytic.....	.31
705-10.....10 pf ceramic disk.....	.15
705-.01......01 uf ceramic disk.....	.12
705-.1......1 uf ceramic disk.....	.17

IC SOCKETS (solder tail)

IC-S-08.....8 pin high quality socket.....	.27
IC-S-14.....14 pin high quality socket.....	.30
IC-S-16.....16 pin high quality socket.....	.34
IC-S-18.....18 pin high quality socket.....	.40
IC-S-28.....28 pin high quality socket.....	.60
IC-C-08.....8 pin economy socket.....	.13
IC-C-14.....14 pin economy socket.....	.15
IC-C-16.....16 pin economy socket.....	.17
IC-C-18.....18 pin economy socket.....	.20
IC-C-28.....28 pin economy socket.....	.40

RESISTORS 5%, 1/4 watt

All EIA values available from 2.0 ohm to 5.1 Meg.

Also available is 10 Meg.

100 each of same value.....	\$1.50
50 each of same value.....	.98
25 each of same value.....	.75
10 each of same value.....	.40
5 each of same value.....	.25

ASSORTMENTS

10 each of 10 values (100).....	3.00
25 each of 10 values (250).....	6.50
50 each of 20 values (1000).....	16.00

CHORUS/DELAY KIT

This chorus/delay unit, designed by Craig Anderton and featured in Guitar Player magazine, provides flanging, slapback echo, and automatic double tracking effects. The delay range is from 2 ms to 80 ms. Due to the use of compression and expansion techniques, the unit has dead-quiet operation up to about 50 ms and only minimal noise out the full 80 ms. This project kit consists of all electronics, pots, jacks, etc. Also included are the two circuit boards (etched, drilled, and legended) needed for the project. Not included is wire, solder, case, knobs, etc. The Chorus/Delay unit also needs a well regulated bi-polar 15 volt power supply (not included). (A punched and legended rack mount panel will soon be available for this project.)

Order KT-CD777..... \$78.00

"SNARE +" DRUM VOICE KIT

This percussion synthesizer was designed by Thomas Henry and appeared in POLYPHONY magazine. Here's what Craig Anderton had to say about the "SNARE +": "At last - an inexpensive drum voice that has a punchy, full sound.All in all, the Snare + delivers a lot of drum sounds, and I would unhesitatingly recommend it to anybody who's tired of the thin sound found in most electronic drum units."

We offer the kit with or without a panel. Kit 3770 contains all electronic parts, switches, jacks, pots, etc, as well as etched, drilled, and legended circuit board. Kit 3772 includes all this plus a punched and legended rack mount panel (standard 1 3/4 by 19 inches) available in black or blue (both with white legends).

Not included with either kit is wire, solder, mounting hardware, etc. The SNARE + also needs a bi-polar 15 volt power supply (not supplied).

KIT 3770 Basic SNARE + kit..... \$33.95
KIT 3772 SNARE + with rack panel... \$44.94

THE "CLARIFIER" GUITAR EQ/PREAMP

The "CLARIFIER" is an onboard preamp/EQ module for guitar. This design, by Craig Anderton, was first seen in the pages of GUITAR PLAYER magazine. Here's what the CLARIFIER will do: Replace the guitar's standard passive tone control with a two control, active circuit which provides over 12 db of bass and treble boost and up to 6 db cut.... Buffer your pickups from external loading, giving additional output and improve high freq response.... Add a nominal 6 db of gain to give your signal a bit more punch, as well as improve the signal/noise ratio in multiple effects systems... make your guitar immune to the high freq loss caused by long cable runs.

The CLARIFIER kit is available in two options, both of which include a high quality drilled, legended, and masked circuit board, as well as complete step by step instructions. Kit 2450 contains everything needed for a complete unit... Kit 2455 contains everything except the pots (for those who prefer a particular brand of potentiometer). Batteries are not included with either kit.

KIT 2450.....Complete CLARIFIER kit . \$18.95
KIT 2455.....CLARIFIER less controls ..\$14.95

TERMS: (Check, Money Order, Cashiers Check - Add .75 if under \$10.00) - \$10.00 minimum on C.O.D. (UPS only) add \$1.50) - (Mastercard and Visa: \$10.00 minimum. You must supply exp. date.) - (Indiana residents add sales tax.)

SHIPPING AND HANDLING: \$1.00 plus 5% of purchase. We will credit any amount over our standard rate.

SATISFACTION GUARANTEED!

SIGNAL DIODE

601-60.....1N914 (1N4148) signal diode . 5/.35

TRANSISTORS

2N3904.....2N3904 NPN Transistor.....	.25
2N3906.....2N2906 PNP Transistor.....	.25

POTENTIOMETERS

(3/8 long shaft, 5/16 mounting hole)	
854-401.....10K Linear taper.....	1.09
854-501.....100K Linear taper.....	1.09
854-505.....500K Linear taper.....	1.09
855-401.....10K Audio taper.....	1.09
855-501.....100K Audio taper.....	1.09
855-505.....500K Audio taper.....	1.09
856-401.....10K Audio taper with on/off switch.....	1.25

TRIM POTS (vertical mount)

802-251.....250 ohm trimmer.....	.40
802-103.....10K trimmer.....	.40

MINI TOGGLE SWITCHES

403-20.....SPDT (on/on) sub-mini (3A).....	1.20
403-40.....DPDT (on/on) sub-mini (3A).....	1.50
405-10.....SPST (on/off) bat handle (6A).....	1.85

LED's

Please note that the typical DC forward current (I-fwd) of these LED's is less than those offered elsewhere making these LED's ideal for battery circuits or others where current consumption is a factor.

305-201.....Red T-1 1/4 jumbo diffused (20 ma).....	.30
305-202.....Green T-1 1/4 jumbo diffused (30 ma).....	.40
305-203.....Dual T-1 1/4 jumbo diffused (50 ma).....	.90
305-204.....Tri T-1 1/4 jumbo diffused (20 ma).....	1.50

Note: 305-204 is a three lead, tri-color (green, red, yellow) device. It is essentially two separate LED's in one package. (The yellow is obtained by turning on both green and yellow.)

JACKS and PLUGS

1/4 In. PHONE JACKS	
901-101.....Mono standard phone jack.....	.45
901-103.....Mono with n/closed contact.....	.52
901-105.....Mono encl. jack (open back).....	.55
902-211.....Stereo standard phone jack.....	.70
902-213.....Stereo encl. jack (open back).....	.77

1/8 In. MINI JACKS	
903-351.....Mono with n/closed contact.....	.32
903-353.....Mono encl. (open back).....	.26
903-355.....Mono enclosed with contact.....	.35

RCA JACKS	
921-100.....RCA jack, chassis mount.....	.34
921-200.....RCA jack on phenolic mount.....	.25
921-300.....Dual RCA on phenolic mount.....	.43

1/4 In. PHONE PLUGS	
911-201.....Mono, black phone plug.....	.48
911-203.....Mono, red phone plug.....	.48
911-205.....Mono, chrome (metal) plug.....	1.20
911-211.....Stereo, black phone plug.....	.65

1/8 In. MINI PLUGS	
913-251.....Mono, black mini plug.....	.38
913-253.....Mono, red mini plug.....	.38
913-255.....Mono, chrome (metal) plug.....	.56

SWITCHING JACKS

These are stereo phone jacks that contain an independent switching system that is controlled by the insertion of the plug. Jack 905-301 contains the equivalent of a DPST normally on switch. Jack 905-302 contains the equivalent of a DPDT on/on switch making it ideal for switching bi-polar power supplies on and off in effects boxes, etc.

905-301.....Stereo jack with SPST switch.....	.90
905-302.....Stereo jack with DPDT sw.....	1.00

PGS ELECTRONICS

Route 25 - Box 304

Terre Haute, IN 47802

PAIA STOMP BOX EFFECTS

AT LOWER THAN 1980 PRICES

These new stomp boxes from PAIA are designed to give electronic guitarists the highest quality effect at the lowest possible price. Cases are formed of heavy steel and covered with the most scuff-resistant baked-on finish available. All feature heavy duty switches for long life and electronic effect switching for pop-free punch-in and punch-out. All are high input impedance, low output impedance, non-inverting, low noise devices designed to meet all proposed FX standards. Each provides hour after hour of operation from a single 9 volt battery and provide automatic power switching; you'll never have to worry about forgetting to turn them off.

HOT LYX SUSTAIN

Probably the most used effect by any electronic guitarist, a sustain unit is essentially an amplifier that automatically increases its gain to compensate for a guitar's normal decay characteristics. The result is the ability to hold notes and chords much longer than would otherwise be possible.

Hot Lyx gives you all the control you need, continuously variable sustain from just enough to make your Silvertone sound like a Les Paul to "pedal to the metal" controlled feed-back settings that give rock-guitar its "all-out" quality. Level control allows for either lower or higher volume levels when you're punched into the effect and can also be used as an over-drive control to give you the sweetest fuzz/sustain sounds you've ever heard.

No. 5710 HOT LYX Sustain \$34.95 (3 lbs.)

MIDRANGER™ Midrange Equalizer

Sure, your amp has bass and treble controls — but what about the all important midrange? When you need more sound from your axe than most amps can give, but don't have the bucks for a fancy equalizer, the MID-RANGER is for you. Featured in Craig Anderton's June 1982 Guitar Player column, this special purpose equalizer gives more presence and "punch" by providing continuously variable boosts of up to 12 db. at switch selectable frequencies of 90, 200, 1000, 2000 or 4000 Hz.

Designed for guitars, voice, rhythm boxes and keyboards, the MIDRANGER features High Input/Low Output Impedance, quiet electronic switching and single 9v. battery supply (not included).

MIDRANGER (tm) Cat. No. 5740 \$32.95 3 lbs.

5750 — AXE GRINDER(tm)

A classic fuzz to FX standards.

The AXE GRINDER might be a pretty routine fuzz if it weren't for a couple of subtle but significant features. Like a Distortion Intensity Knob that provides smooth control of clipping from just a hint when you really get it on to pure square waves when you even think of picking.

And the Distortion Tone, Distortion Level, and Clean Level controls are like having a built in mixer and E.Q., letting you precisely set the amount of distortion and its tone as well as the mix of clean and distorted signal. You probably never realized you could get so many sounds from a "simple" fuzz.

The AXE-GRINDER also features totally pop-free electronic switching and adherence to uniform FX standards that allow any Effect to work with any other without concern for mismatch noises or phase incoherence. 9 volt battery power (not supplied). 5750 Axe Grinder(tm) Kit . . . \$29.95 3 lbs.

5760 ROCKTAVE DIVIDER(tm)

Whereas most effects that alter the harmonic content of a signal can only produce or accentuate frequencies higher than the fundamental frequency produced by the instrument, the ROCKTAVE DIVIDER fills out your sound by adding in wave-forms that are sub-harmonics of those produced by your axe.

Comporand stages are used to stabilize input for reliable triggering of the divider circuitry and to impress the original dynamics of your playing onto the newly created subharmonics.

Independent level controls on the extracted fundamental and first and second sub-octaves allow you to produce just the mix you're after and master tone control lets you round the square wave sub-octaves off to near-sinusoidal purity.

The ROCKTAVE DIVIDER also features automatic power switching when in use, pop-free electronic cancel function and single 9 volt battery power source (battery not supplied). 5760 Rocktave Divider(tm) \$39.95 3 lbs.

MOTION FILTER

An envelope follower/filter combination translates the normal dynamic properties of your axe into modulated timbral changes as well, the effect is like a wah-wah pedal being used by someone with magic feet. The first time you get your MOTION FILTER working you won't believe that so much funk and soul can be squeezed into such a tiny box.

Independent Initial Frequency and Sensitivity knobs give you the control you need to realize a wide range of effects and allow the MOTION FILTER to be used with either electric bass or guitar. No. 5720 MOTION Filter Kit . . \$29.95 (3 lbs.)

GATOR™ Noise Gate/Envelope Controller

The almost un-noticeable "hiss or swish" that each unit in a multiple-effects system adds to your music can sum to annoyingly noticeable background noise just when things are supposed to be quiet. GATOR listens while you play, and when you stop, electronically isolates your effects from your amplifier, zapping noise completely.

And despite its low cost, GATOR has added features that let you do more than just make other effects sound good. It's an important effect in its own right.

The ATTACK control lets you re-shape the normal percussive envelope of your guitar for bowed string and organ effects with attack times up to 1.5 sec. and an AUXILIARY TRIGGER SIGNAL INPUT allows the dynamics of one instrument to be gated by another (drums, for example) to impart unique "synchro sonic" rhythmic characteristics to your sound.

Other features include High Impedance In/Low Impedance Out, Electronic Footswitch for quiet punch in/out, wide range Threshold Control, Single 9v. battery supply (not included). GATOR (tm) Cat. No. 5730 \$34.95 3 lbs.



QUALITY
EFFECTS
AFFORDABLE
PRICES

ORDER TOLL FREE WITH VISA OR MASTERCARD
1-800-654-8657

DIRECT MAIL ORDERS & INQUIRIES TO:

PAIA Electronics, Inc.

1020 W. Wilshire, Oklahoma City, OK 73116 • (405)843-9626